

Fire-tested support and routing systems

Building Connections

Digitalisation, the Energiewende (energy transition), mobility – the future is gathering speed. At OBO Bettermann, we're proud to be a driving force. And as a facilitator, we make connections. Today, we are already developing the innovative electrical infrastructure systems and solutions of tomorrow. Reliably, flexibly, sustainably.

Already today, OBO is one of the leading manufacturers of installation systems for the electrical infrastructure in buildings and plants. When it comes to the friction-free flow of power, energy and data, engineers and tradespeople worldwide rely on the comprehensive range from OBO.



OBO applies its slogan "Building Connections" to around 30,000 high-quality branded electrical products and services, which are used in application solutions for projects in industry, business and infrastructure.

OBO operates a global network and employs more than 4,200 people in more than 60 countries. The headquarters of the family company, which was founded in 1911, is located in Menden, Germany. In addition, more than 40 subsidiaries are present in markets on all continents.

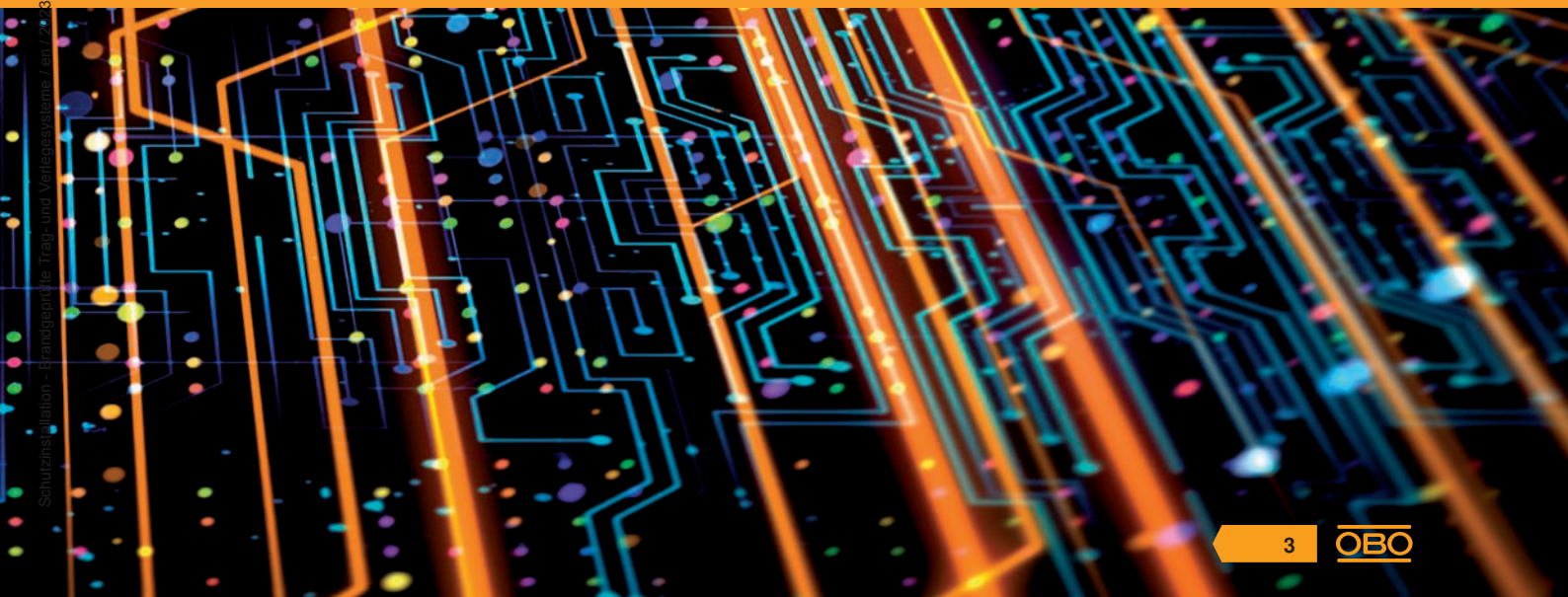

Improved structure, sharpened profile



Each of our products carries a benefit which only the OBO brand can offer. Products are developed, manufactured and tested with a high level of competence – from the idea through to the final check. From flawless logistics through to practical information – we can provide support at every level. We can offer additional security through certificates on the conformity of our products with the most important standards and directives. In a nutshell – OBO helps you more. In every location and in every phase of a project.

To maintain this, we continually challenge ourselves. Not as an end in itself but for the better processing of each customer's requests – fast, reliably and future-oriented. That is the reason we have not only established our three central application areas, but also reworked our catalogue structure. In this way, we can display our service offers more clearly, highlight the product benefits more effectively and illustrate the respective application areas more tangibly.

OBO Product Worlds



Industrial installations

- Cable support systems
- Connection and routing systems
- Fastening material



Building installations

- Cable routing systems
- Device installation ducts, trunking and poles
- Floor installation systems and underfloor applications
- Installation systems



Safety and protection installations

- Surge protection
- External lightning protection
- Equipotential bonding and earthing
- Insulation and cable bandages
- Fire-tested support and routing systems
- Fire protection ducts



It's your choice – from now on there's a catalogue for each OBO product category. Simply select the catalogues and order together with a collection case.

OBO Support & *contact*



***You have a
problem?
We have the
solution!***

OBO Bettermann is more than the sum of its products. In any situation, we are the reliable partner right by your side. You have a problem? We have the solution!

It doesn't matter in which area of industry our support is needed – from industrial and plant engineering to private, public and administrative buildings, as well as in the areas of mobility and renewable energies – we have everything that you need.

OBO can not only provide the entire electro-technical infrastructure with the best possible products. We can also support you with sound expert knowledge and more than 100 years of experience, right from the planning phase through to the realisation of your projects. OBO – solutions you can rely on.

You can contact our Customer Service department on:

Customer Service

Tel.:+49 23 73 89 - 17 00

Monday–Thursday
07.30–17.00

Friday
07.30–15.00

export@obo.de

What is OBO Support?

Every OBO product carries a plus inside it, which only a branded product can offer. It is developed, manufactured and tested with a high level of competence, from the idea right through to the final check. In addition, our specialists are available for consultation and can offer you assistance and training courses for products at any time.

Together with you, we plan your project and help you choose the right products, and are also available to you at any time should you need us. From flawless logistics through to practical information – we can provide support at every level. We can offer security through certificates on the conformity of our products with the most important standards and directives.

We are as flexible as you are – because we know how practical people work and what is important to them. Each step is a plus – that is the OBO Support concept.



Service



Training



Handling



Certification

Service – OBO can help

Everywhere and in every project phase:

- Highly competent hotline
- Product and system information, digitally or printed
- Selection and planning aids on the web, as an app, as a CAD application or in printed form
- 2D and 3D product data for planning
- Field service, branch offices and subsidiaries in 60 countries
- Engineering services for major projects

Training courses from OBO

- Seminars and workshops
- Local consultation and training courses
- Planner days

Handling – OBO delivers reliably

With optimised delivery processes:

- Reliable logistics
- Practical transport systems and packaging
- Loading gear handling and disposal concepts

Certification and guarantee

OBO offers safety. Our products fulfil the most important country-specific regulations:

- Conformity (e.g. IEC, VDE, CE, KEMA, KEUR, UL)
- Certification (e.g. DIN EN, DGNB)
- 5-year guarantee for surge protection products
- Guarantee management

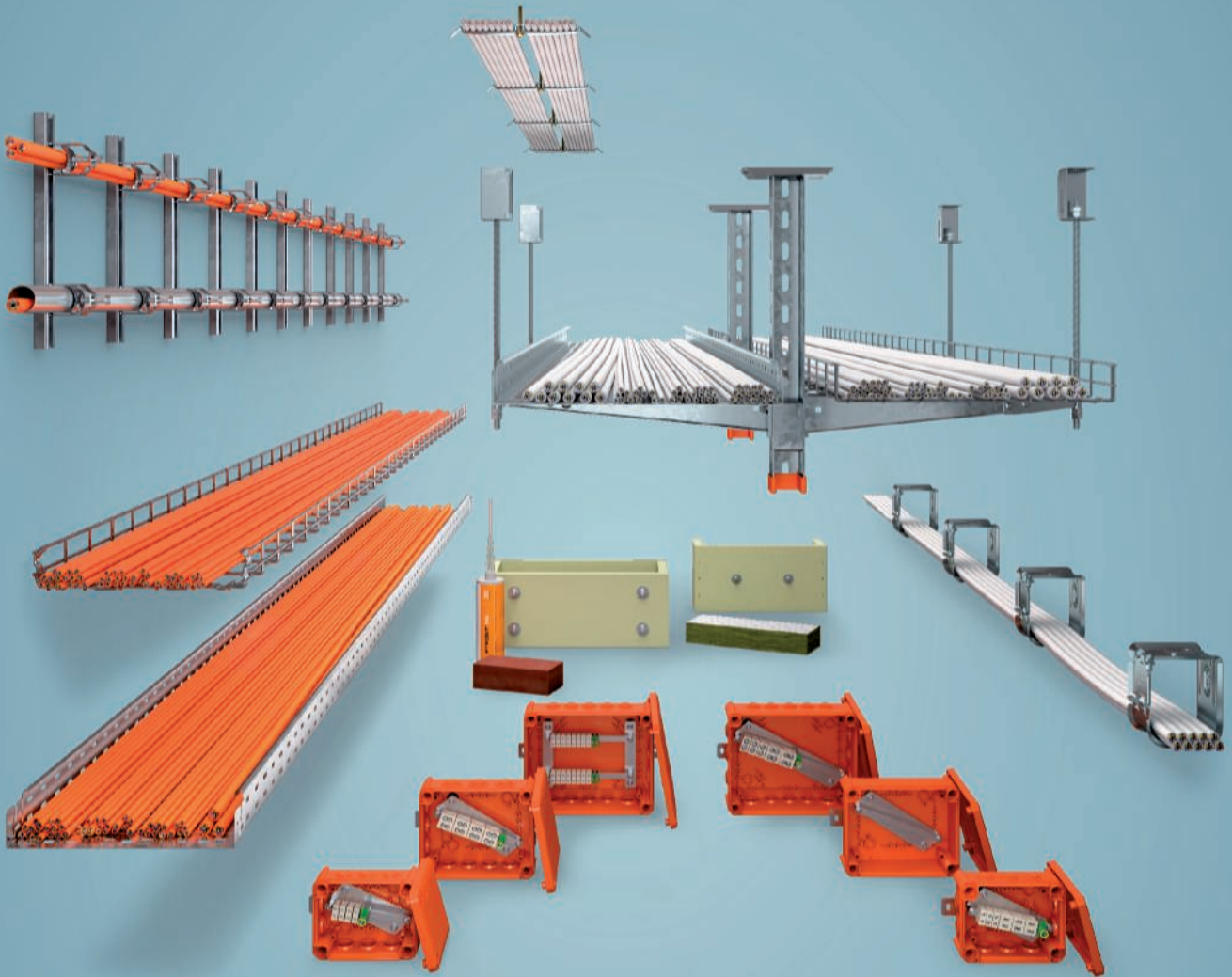

Planning aids

Page 10



Systems for the maintenance of electrical function, FireBox T series junction boxes

Page 20



Systems for the maintenance of electrical function, cable-specific routing variants

Page 30



Systems for the maintenance of electrical function, fire-tested individual routing systems

Page 68



Escape route installations, false ceiling mounting

Page 82



Anchorings

Page 104



Directories

Page 116





Schutzinstallation - Brandgeprüfte Trag- und Verlegesysteme / en / 2023/07/26 07:51:39 07:51:39 (LLEspot_03599) / 02/07/23

Planning aids

First protection aim: Maintenance of the fire sections

Insulation systems

Second protection aim: Protection of escape routes

Escape route installations

Third protection aim: Function maintenance for electrical systems

Systems for the maintenance of electrical function

Technical support



First protection aim: Maintenance of the fire sections



Insulation systems reliably seal the ceiling and wall penetrations required for installations against fire and smoke.

The division of buildings into fire sections protects unaffected building sections against the spread of fires for specific periods of time. Insulation maintains the fire sections, thus limiting the spread of fire and smoke. These constructive measures protect people and property, allowing fire brigades to prevent the spread of fires to other parts of the building through extinguishing measures.

Function of firewalls

Firewalls should ensure that a fire cannot pass to neighbouring buildings or building sections. This creates so-called fire sections. The construction design of these firewalls (materials, fire resistance classes, stress values) is regulated by building regulations and standards.

Electrical cables and pipes may only be run through walls and ceilings at the ends of rooms when there is a guarantee that they do not present an opportunity for fire and smoke to spread. Insulation systems reliably seal the ceiling and wall penetrations required for installations against fire and smoke.

Special requirements

The following requirements apply to cable penetrations with cable insulation:

- The spread of fire and smoke must be prevented
- Room closure must be guaranteed
- On the side of the insulation away from the fire, the surfaces of cables, pipes, cable support systems and the surface of the insulation may not heat up to an impermissible level

Insulation systems and cable bandages



Mortar insulation systems

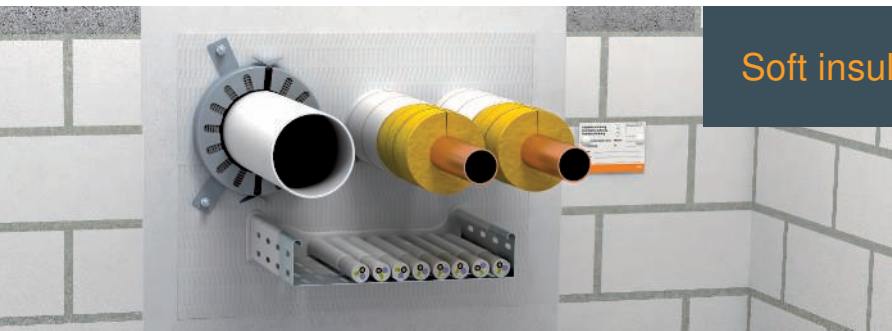

Soft insulation systems



Foam systems



Pipe shell systems



Cable bandages

Schutzinstallelemente Brandgeprüfte Trag- und Verlegesysteme / 2023/07/26 07:51:39 (LLExpert_03599) / 2023/07/26

Second protection aim: Protection of escape routes



2

Approximately 95% of all deaths during fires are caused by smoke poisoning! In case of fire, emergency and escape routes are the central lifeline of the building and must remain usable under all circumstances.

What is an emergency and escape route?

According to the construction regulations, there must be routes in buildings which not only permit access to the building in a horizontal and vertical direction in normal situations, but which also offer the option of rescue in case of fire. It is therefore obligatory to equip buildings with at least one constructive emergency and escape route. Additional emergency and escape routes may also be necessary, depending on the type of building.

These include:

- Necessary staircases (vertical access)
- Connecting rooms between the necessary stairwells and exits to the outside
- Necessary corridors (horizontal access)

There must be a guarantee that, if there is a fire, these routes can be used to leave the building without any risk. In addition to evacuation, the emergency and escape routes also aid the local fire brigades as a point of attack.

In the area of emergency and escape routes, an installation may not pose an additional fire load. This requirement can be fulfilled using an appropriate type of installation:

- Concealed installation
- Installation in fire protection duct systems
- Installation above suspended fire protection ceilings
- Use of non-combustible materials
- Routing of cables with improved behaviour in case of fire

Escape route installations

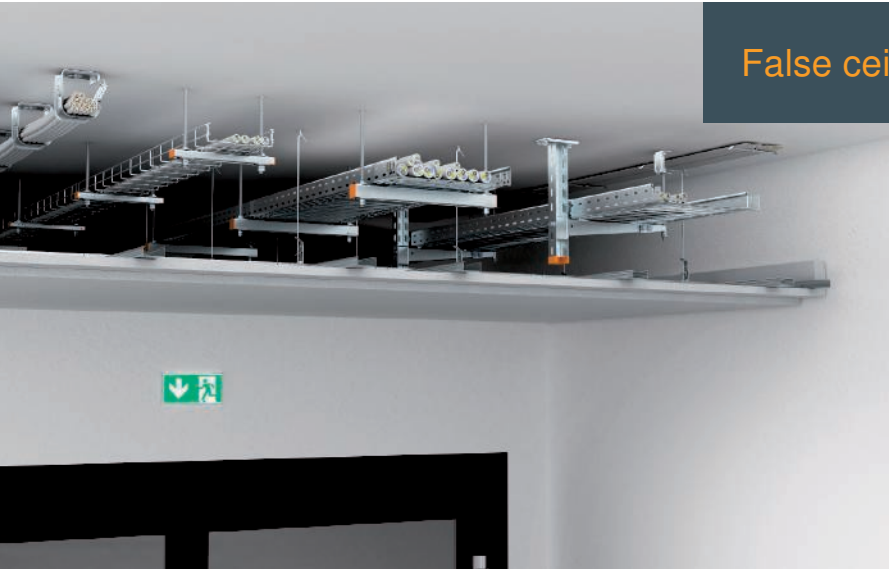

False ceiling mounting

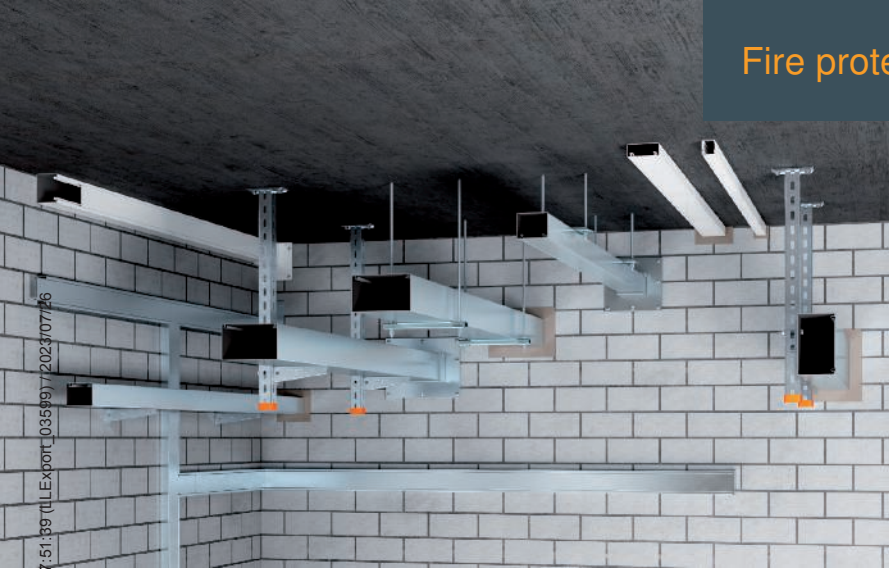

Fire protection ducts, metal

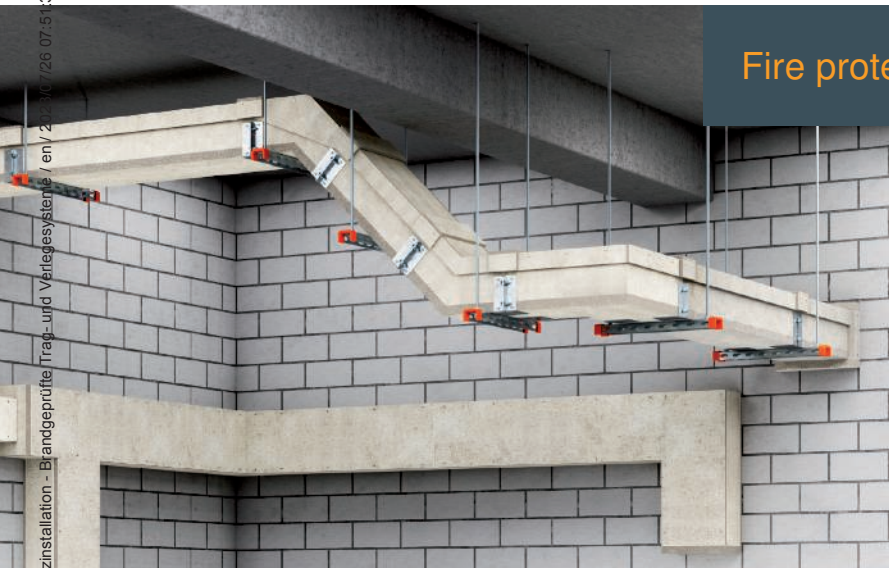

Fire protection ducts, concrete

Schutzinstallation - Brandgeprüfte Trag- und Verteilungssysteme / en/ 20.3.2017/26.07.2017/51.39 07:51:39 (LLEXP00T_03599)/2023/07/16

Third protection aim: Maintaining the functionality of electrical systems



3

E30

E90

If there is a fire, emergency and escape routes must remain usable and important technical equipment, such as emergency lighting, fire alarm systems and smoke extraction systems, must continue to function. Therefore, it is essential that the power supply for these systems is specially protected. In addition, certain technical systems must support the fire brigades in fighting fires for a sufficiently long period of time.

Where is the maintenance of electrical function required?

Technical equipment with maintenance of electrical function is required for the following buildings and systems:

- Hospitals
- Hotels and restaurants
- Tower blocks
- Meeting points
- Commercial buildings
- Closed large garages
- Underground railway systems
- Chemicals industry
- Power stations
- Tunnels

This could be because these constructions are regularly frequented by many people, which creates an increased safety risk for gatherings of people. However, with certain systems, property and the environment must also be protected.

30 minutes: Maintenance of electrical function for safe evacuation and rescue

The first 30 minutes after the start of a fire play an important role. For the affected building to be cleared quickly the maintenance of electrical function must be guaranteed for the following equipment during this time:

- Safety lighting systems
- Lifts with fire control
- Fire alarm systems
- Alarm systems and systems to issue instructions
- Fire extraction systems

90 minutes: Maintenance of electrical function for effective firefighting

To support firefighting operations, it is imperative that certain technical equipment is supplied with sufficient power even up to 90 minutes after a fire breaks out in a building. This equipment includes:

- Water pressure increase systems for fire water supply
- Mechanical smoke extraction systems and smoke protection pressure systems
- Fire brigade lifts
- Bed lifts in hospitals and similar equipment

Systems that maintain the electrical function



Cable trays and cable ladders



Vertical ladders



Individual routing

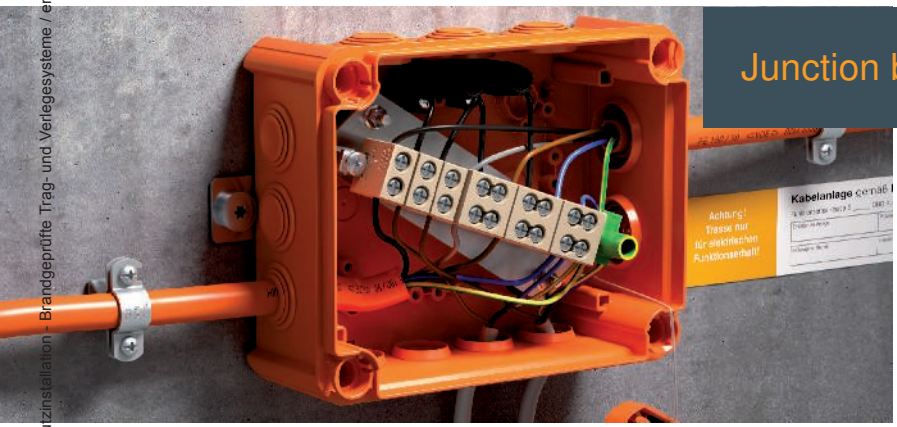

Junction boxes

Schutzinstallation - Brandgeprüfte Trag- und Verlegesysteme / en / 2023/07/26 17:51:39 (LH-xp01_03599) / 2023/07/26

Technical support



OBO BSS seminars: First-hand knowledge

With a comprehensive programme of training courses and seminars on the subject of fire protection systems, OBO is able to support its customers with specialist knowledge from a single source. Alongside the basic theoretical principles, the programme also deals with practical implementation in everyday applications. Special calculation and application examples round off the comprehensive programme of knowledge transfer.

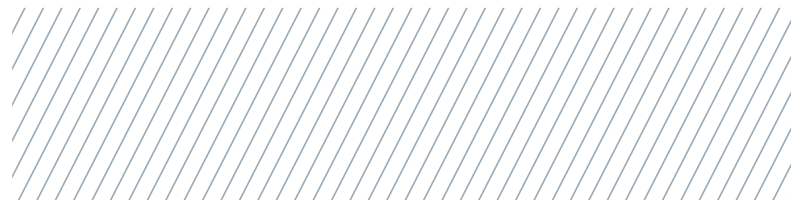

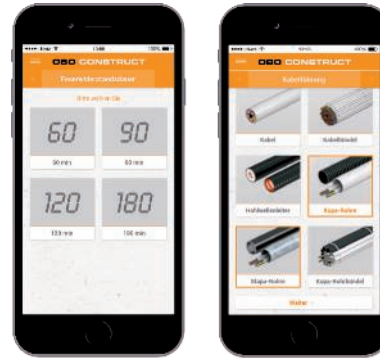

The OBO construct BSS online Tool

It works on any computer with Internet access. The BSS software simplifies the planning of suitable fire protection systems. After the basic data has been entered, the user obtains an overview of the approved insulation systems, as well as of any necessary and optional system accessories. Thus, they can create, edit and export a personal shopping list in a targeted manner. All the key information on standards and approvals can be found directly with the systems.

BSS app

The OBO Construct BSS app makes finding the right product even quicker. In only a short time, the app determines the fire protection systems required for the appropriate project. It offers the full scope of the Construct BSS module, allowing simple planning and material calculations in any location. It's extremely practical, as the parts list can be sent directly by e-mail. The app is available for Android and Apple devices from Google Play Store and the iTunes App Store.



Fire protection guide for electrical installations

In the second edition of the fire protection guide, we have again compiled lots of useful information. The interconnections of fire protection between different types of technical building equipment are now explained in even more detail. Perhaps you will find some new information in this edition which can help you in the planning and implementation of fire protection systems.

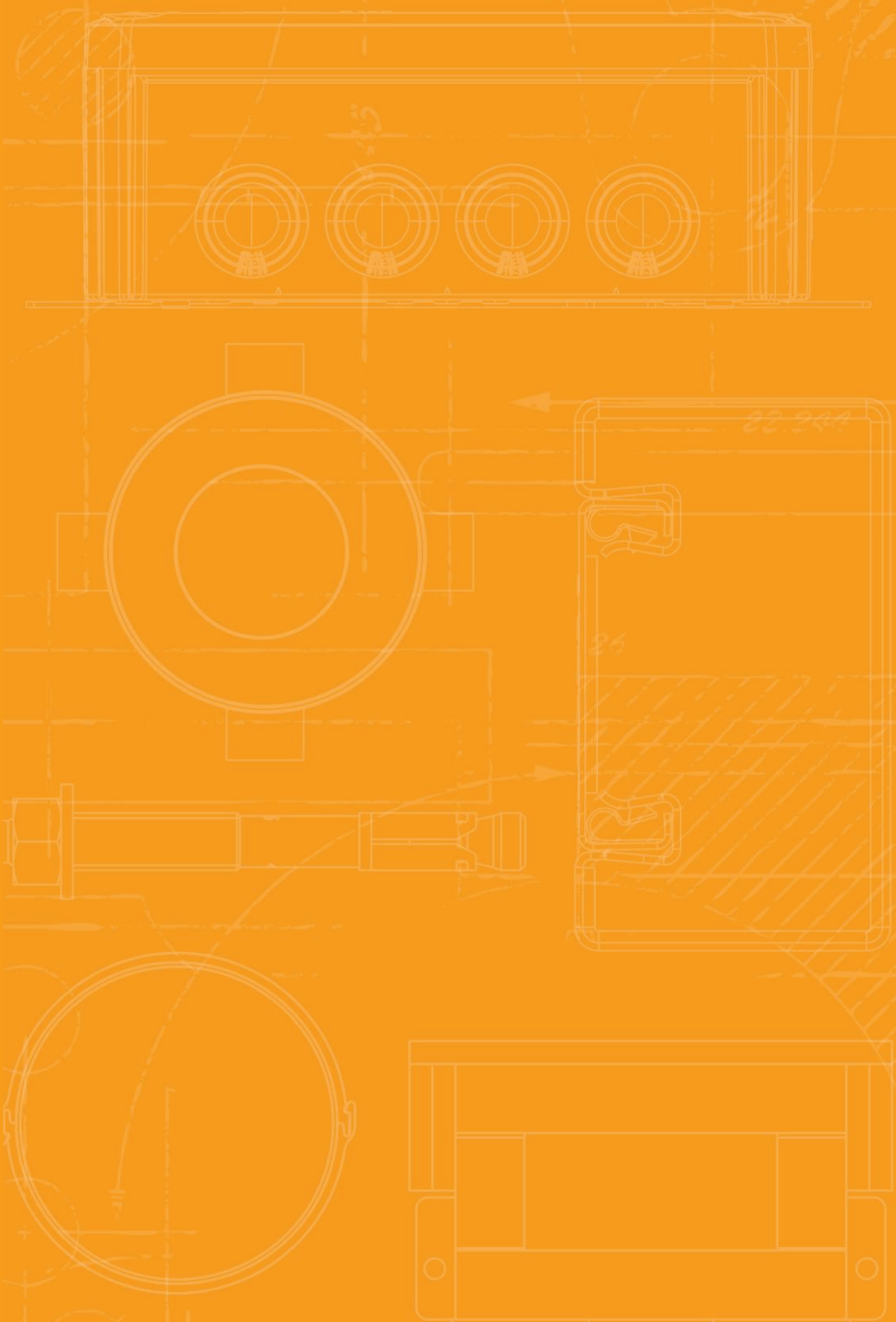

Systems for the maintenance of electrical function, Firebox T series junction boxes



Junction boxes

22



Accessories, junction boxes

28



Junction box, FireBox System description

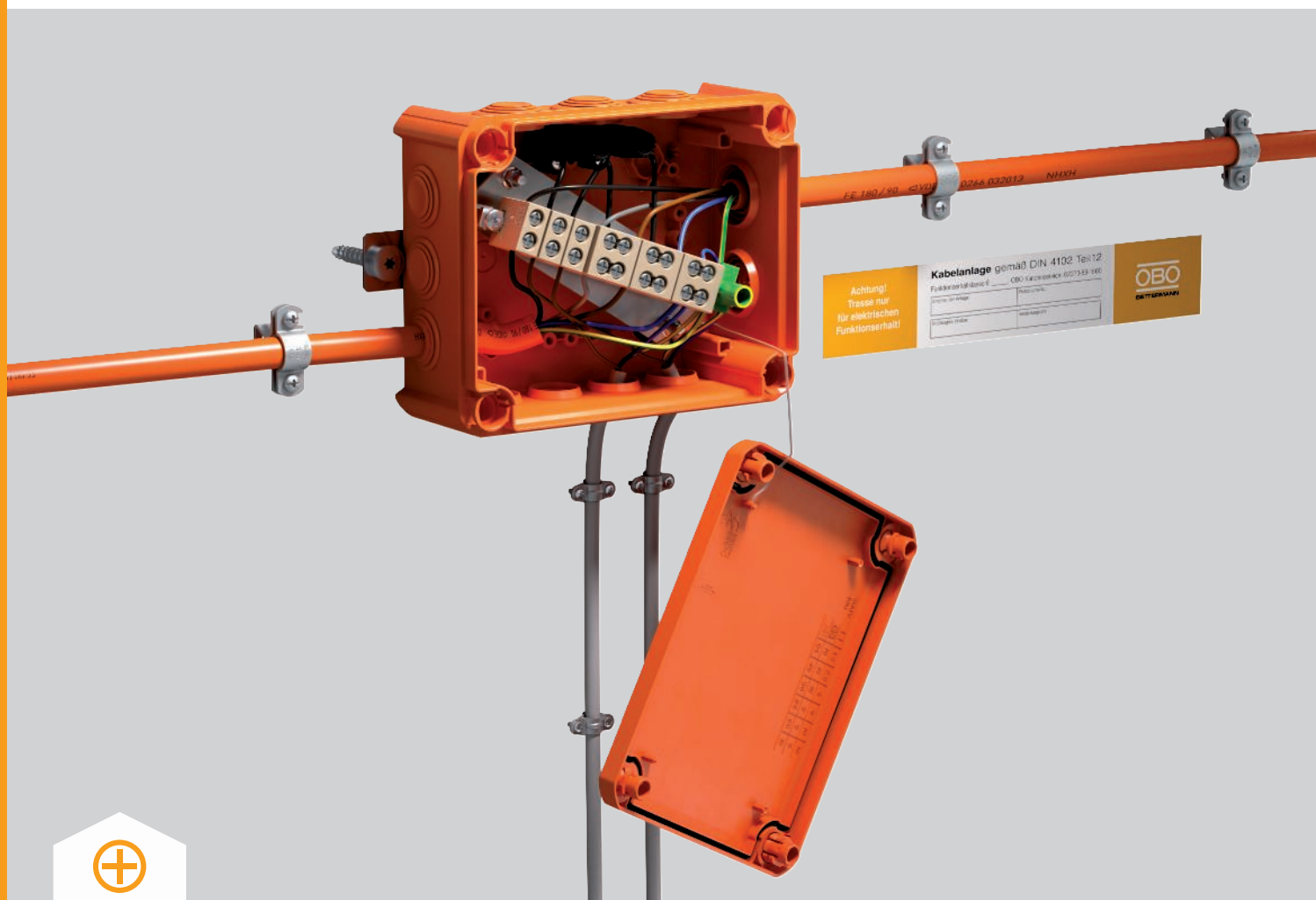

Junction boxes of the FireBox series are available for connecting and branching safety cables. These are equipped with a high-temperature-resistant connection unit with ceramic terminals and offer clamping areas of 0.5 mm² to 16 mm² of copper cross-section with single or double terminals. The T series FireBox possesses all the benefits of thermoplastic cable junction boxes, which allow the insertion of cables without tools and have a protection rating of IP66. The high-temperature-resistant terminals are pre-mounted on the connection unit. The protective conductor terminal is connected to the support clamp, meaning that covers of the metal parts are not required. The closed variants of the FireBox have support clamps and fastening elements made of stainless steel so they can also be used in aggressive environments.

In the closed sides of the boxes cable glands can be placed freely. Ceramic terminals of different nominal cross-sections can be arranged freely onto the support clamps according to electro-technical requirements. The junction boxes for data technology feature an even number of ceramic terminals. The terminals have wire protection which – with the common wire diameters of 0.5 mm² – decreases the risk of the copper being damaged. Fastening of all variants takes place on the outer straps with fire protection bolt ties. The FireBox is tested and approved as a connection socket for the maintenance of electrical function to DIN 4102 Part 12 with the classes E30, E60 and E90. A separate fuse holder allows the protection of branches.

Junction box, FireBox Installation principle



Fastening of the FireBox with a screw anchor and inserting the fuse holders.

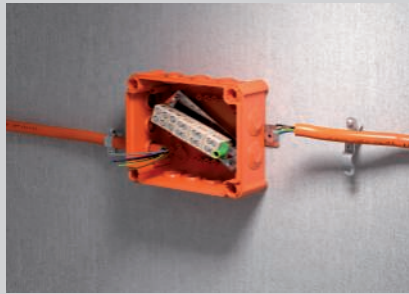

Cable insertion via plug-in seals.

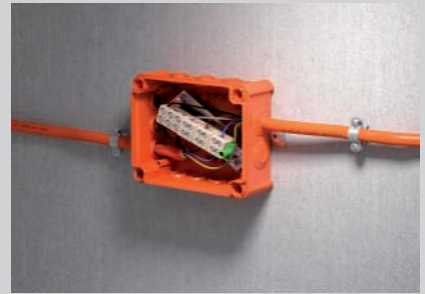

Diagonally arranged terminal strip with large wiring space.

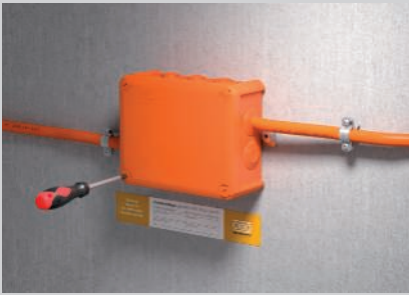

Closing the box with the lid and attaching the identification label.

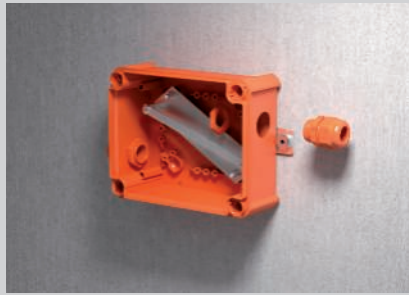

Free positioning of cable glands in the closed sides of the empty variants.



Empty variants offer the option to individually equip the box with different terminals.

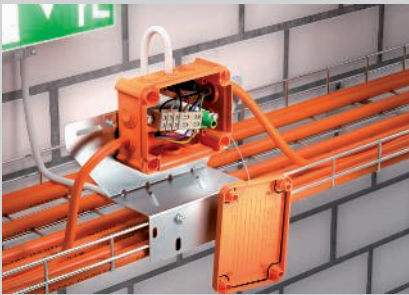

FireBox with mounting plate, type F, mounted to the front of a cable tray.



FireBox with mounting plate, type B, mounted to the rear of a cable ladder.



Standard-conforming mounting of the FireBox on walls and ceiling.

Classification according to DIN 4102 Part 12

E30

E60

E90

FireBox with plug-in seals, single terminals



Type	Nominal cross-section mm ²	Single terminals	Protective terminal	Entries	Pack Piece	Weight kg/100 pc.	Item no.
T100ED 06A	6	4	1	8xM25 2xM32	1	42.730	7205740
T160ED 10A	10	4	1	7xM25 5xM32	1	62.918	7205742
T250ED 16A	16	4	1	9xM25 7xM32	1	92.919	7205744

Connection box with soft plug-in seals. Sufficiently large wiring compartment through diagonally arranged connection unit with completely pre-mounted, high-temperature-resistant ceramic terminals. Green-yellow labelled protective conductor terminal. Fastening on easily accessible external flaps. Approved for cable systems that maintain the electrical function according to DIN 4102 Part 12 with the classes E30, E60 and E90. Ceramic clamps have been tested according to DIN EN 60998-2-1:2004.

Including 2 x MMSplus P 6x35 screw ties.

Dimensions

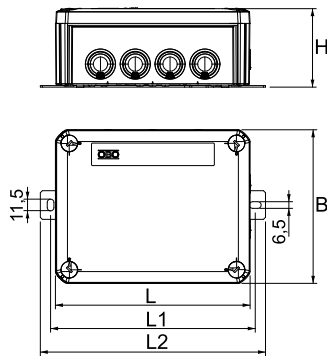

Type	Dim. L mm	Dim. L1 mm	Dim. L2 mm	Dim. B mm	Dim. H mm
T100ED 06A	150	162	182	116	67
T160ED 10A	190	200	220	150	77
T250ED 16A	240	250	270	190	95

FireBox with plug-in seals, double terminals



Type	Nominal cross-section mm ²	Double terminals	Protective terminal	Entries	Pack Piece	Weight kg/100 pc.	Item no.
T160ED 10-2A	10	4	1	7xM25 5xM32	1	71.998	7205748
T250ED 16-2A	16	4	1	9xM25 7xM32	1	105.679	7205750

Junction box with ceramic double terminals and soft plug-in seals. Sufficiently large wiring compartment through diagonally arranged connection unit with completely pre-mounted, high-temperature-resistant ceramic terminals. Green-yellow labelled protective conductor terminal. Fastening on easily accessible external flaps. Approved for cable systems that maintain the electrical function according to DIN 4102 Part 12 with the classes E30, E60 and E90. Ceramic clamps have been tested according to DIN EN 60998-2-1:2004.

Including 2 x MMSplus P 6x35 screw ties.

Dimensions

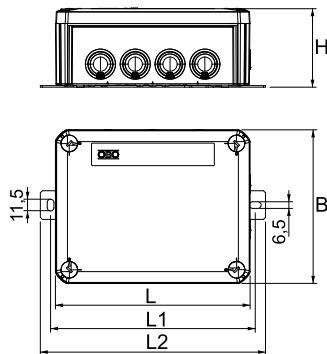

Type	Dim. L mm	Dim. L1 mm	Dim. L2 mm	Dim. B mm	Dim. H mm
T160ED 10-2A	190	200	220	150	77
T250ED 16-2A	240	250	270	190	95



PP

FireBox with plug-in seals, 1 fuse holder

Type	Nominal cross-section mm ²	Single terminals	Double terminals	Protective terminal	Entries	Pack Piece	Weight kg/100 pc.	Item no.
T100ED 06AF	6	3	2	1	8x M25 2x M32	1	48.650	7205752
T160ED 10AF	10	3	2	1	7x M25 5x M32	1	70.513	7205754
T250ED 16AF	16	3	2	1	9x M25 7x M32	1	104.854	7205756



Junction box with one fuse holder and soft plug-in seals. Sufficiently large wiring compartment through diagonally arranged connection unit with completely pre-mounted, high-temperature-resistant ceramic terminals. Green-yellow labelled protective conductor terminal. Fastening on easily accessible external flaps. Approved for cable systems that maintain the electrical function according to DIN 4102 Part 12 with the classes E30, E60 and E90. Ceramic clamps have been tested according to DIN EN 60998-2-1:2004.

Including 2 x MMSplus P 6x35 screw ties.

Type	Dim. L mm	Dim. L1 mm	Dim. L2 mm	Dim. B mm	Dim. H mm
T100ED 06AF	150	162	182	116	67
T160ED 10AF	190	200	220	150	77
T250ED 16AF	240	250	270	190	95

Dimensions

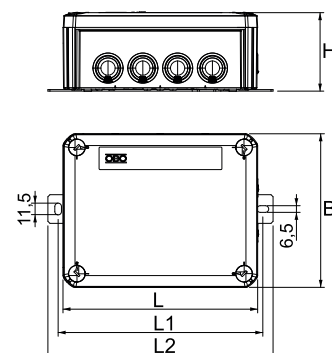

PP

FireBox with plug-in seals, 2 fuse holders

Type	Nominal cross-section mm ²	Single terminals	Double terminals	Protective terminal	Entries	Pack Piece	Weight kg/100 pc.	Item no.
T100ED 06A2F	6	3	3	1	8x M25 2x M32	1	52.950	7205758
T160ED 10A2F	10	3	3	1	7x M25 5x M32	1	77.188	7205760
T250ED 16A2F	16	3	3	1	9x M25 7x M32	1	113.054	7205762



Junction box with two fuse holders and soft plug-in seals. Sufficiently large wiring compartment through diagonally arranged connection unit with completely pre-mounted, high-temperature-resistant ceramic terminals. Green-yellow labelled protective conductor terminal. Fastening on easily accessible external flaps. Approved for cable systems that maintain the electrical function according to DIN 4102 Part 12 with the classes E30, E60 and E90. Ceramic clamps have been tested according to DIN EN 60998-2-1:2004.

Including 2x MMSplus P 6x35 screw ties.

Type	Dim. L mm	Dim. L1 mm	Dim. L2 mm	Dim. B mm	Dim. H mm
T100ED 06A2F	150	162	182	116	67
T160ED 10A2F	190	200	220	150	77
T250ED 16A2F	240	250	270	190	95

Dimensions

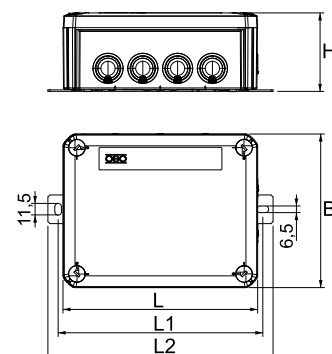

Closed FireBox, empty



Type	Nominal cross-section mm ²	Equipment	Dim. A mm	Pack Piece	Weight kg/100 pc.	Item no.
T100E OVA	0.5-6	Support rail	101	1	33.890	7205780
T160E OVA	0.5-10	Support rail	130	1	49.203	7205782
T250E OVA	0.5-16	Support rail	286	1	74.084	7205784
T350E OVA	0.5-16	Support rail	386	1	121.611	7205786

Unequipped, closed connection or junction box for free termination with ceramic terminals and cable glands. Dimension A states the available support rail length for the wiring terminals. Sufficiently large wiring compartment through diagonally arranged support rail. Fastening on easily accessible external flaps made of stainless steel. Approved for cable systems that maintain the electrical function according to DIN 4102 Part 12 with the classes E30, E60 and E90.

Dimensions

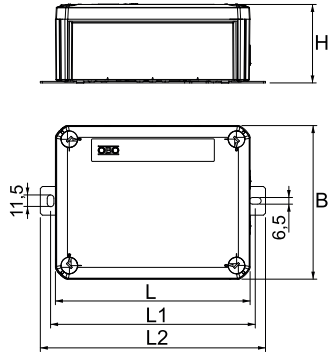

Type	Dim. L mm	Dim. B mm	Dim. H mm	Dim. L1 mm	Dim. L2 mm
T100E OVA	150	116	67	162	182
T160E OVA	190	150	77	200	220
T250E OVA	240	190	95	250	270
T350E OVA	285	201	120	205	230



Ceramic terminal

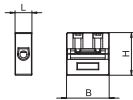

Type	Nominal cross-section mm ²	Dim. L mm	Dim. B mm	Dim. H mm	Pack	Weight	Item no.
					Piece	kg/100 pc.	
TK 04	0.5-4	8.5	21.5	21.5	5	0.880	7205700
TK 06	6	8.5	21.5	21.5	5	0.880	7205702
TK 10	10	12.5	24	24	5	1.930	7205704
TK 16	16	15	28	28	5	3.160	7205706

High-temperature-resistant ceramic terminal for refitting of the FireBox T series. Tested according to DIN EN 60998-2-1:2004.

Ceramic terminal, double

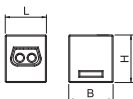

Type	Nominal cross-section mm ²	Dim. L mm	Dim. B mm	Dim. H mm	Pack	Weight	Item no.
					Piece	kg/100 pc.	
TK 06-2	6	19.5	21	22.5	5	2.500	7205703
TK 10-2	10	24.5	26.5	26	5	4.200	7205705
TK 16-2	16	27	29.5	30.5	5	6.400	7205707

High-temperature-resistant ceramic terminal with four connection options for refitting of the FireBox T series. Tested according to DIN EN 60998-2-1:2004.

Cable gland with locknut as a set

PA



Type	Thread	Pack	Weight	Item no.
		Piece	kg/100 pc.	
V-TEC VM20+ OR	M20x1,5	10	1.106	7205660
V-TEC VM25+ OR	M25x1,5	10	1.710	7205663
V-TEC VM32+ OR	M32x1,5	10	2.840	7205666
V-TEC VM40+ OR	M40x1,5	10	5.150	7205669

Robust cap nut cable gland with metric connecting thread to IEC 423, including pre-mounted locknut. For high tightness requirements. Strain relief, torsion protection and tightness over the whole clamping area. Sealing ring made of polychloroprene/acrylonitrile butadiene rubber. Moulded shaped sealing lip on intermediate support, no connection thread sealing ring required. VDE-tested according to DIN EN 50262, protection rating IP68 at 5 bar for 1 hr. For maintenance of electrical function according to DIN 4102 Part 12 in connection with the closed junction boxes of the FireBox T series. Colour: Pastel orange.

Dimensions

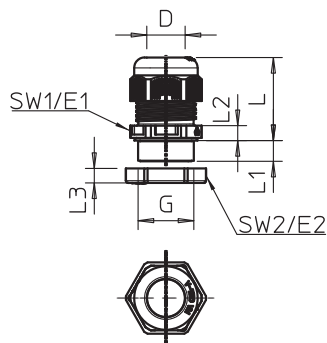

Type	Dim. G mm	Sealing range D mm	Dim. L min mm	Dim. L max mm	Dim. L1 mm	Dim. L2 mm	Dim. L3 mm	SW 1 mm	Dim. E1 mm	Dim. SW 2 mm	Dim. E2 mm
V-TEC VM25+ OR	M25x1,5	9-17	26	35	10	6	6.5	29	32	32	36
V-TEC VM32+ OR	M32x1,5	15-21	29	40	11	6	7	36	41	41	46
V-TEC VM40+ OR	M40x1,5	16-28	36	46	11	7	7.5	44	50	50	56



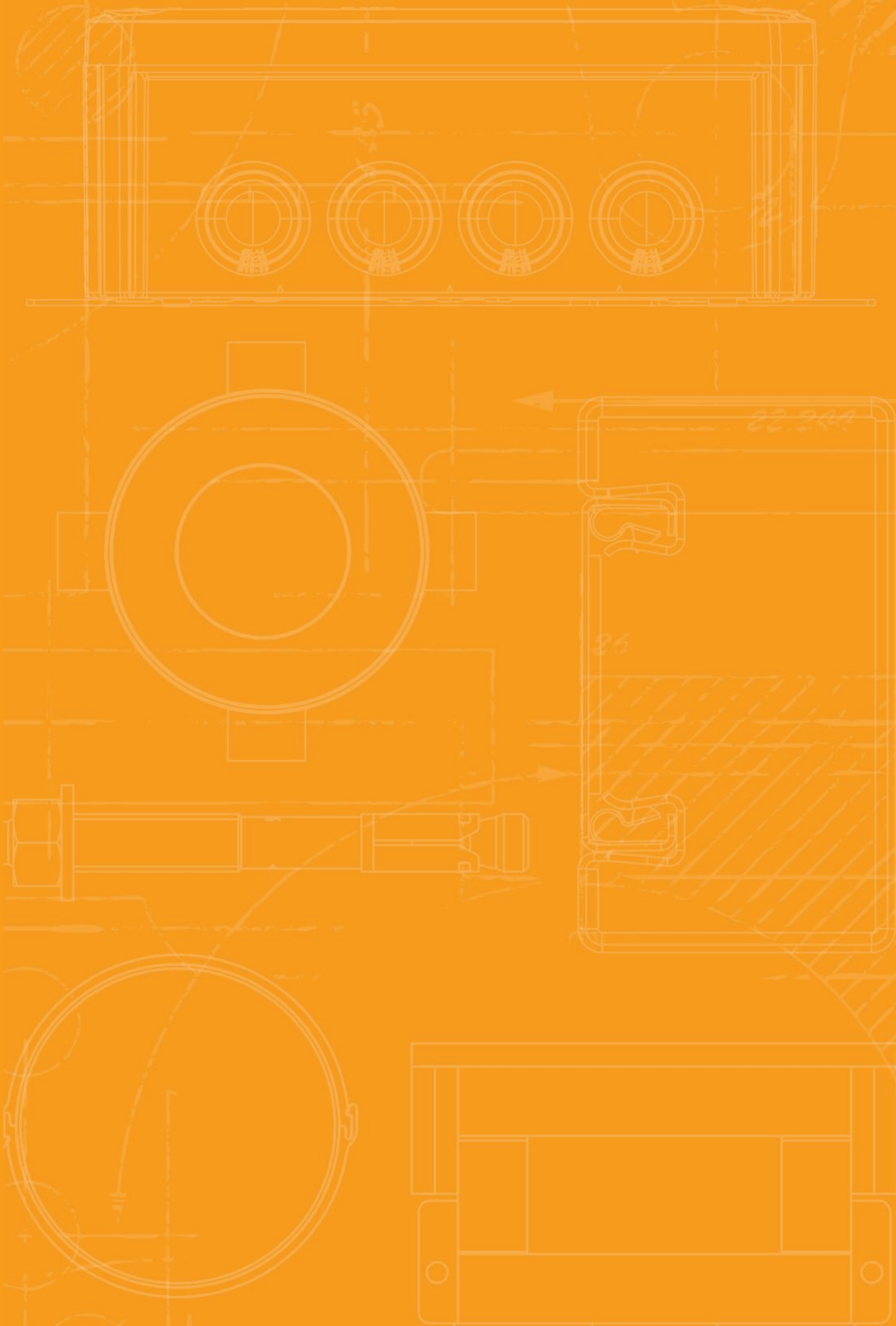

Systems for the maintenance of electrical function, cable-specific routing variants



RKS-Magic® cable tray

32

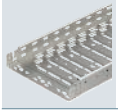

RKS-Magic® cable tray, stainless steel

56

RKS-Magic® cable trays

System description

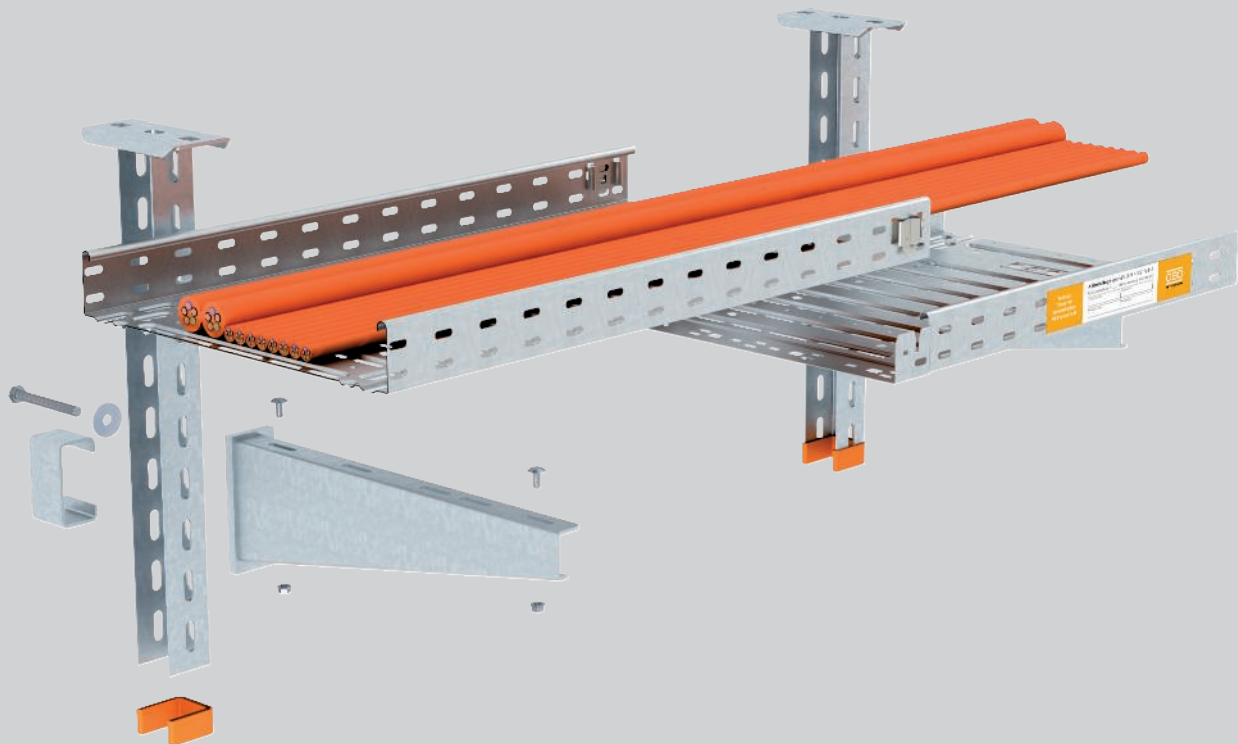

The RKS-Magic® cable tray has been tested as a cable-specific support construction for the maintenance of electrical function according to DIN 4102 Part 12 and approved for maintenance of electrical function classes E 30 to E 90. A threaded rod lock is not required at the tip of the bracket. This saves not just material but also considerably simplifies and speeds up the installation of cables. The screwless connection system allows interconnection of the RKS-Magic® cable trays

without tools and in a particularly quick and economic manner. To ensure the maintenance of the electrical supply, only the locking lugs in the base need to be bent after the trays have been connected. The double material thickness in the joint area and the beading in the base mean that the cable tray has a very high load capacity. The installation of fittings in the section route is permitted, as is the mounting of separating retainers.

RKS-Magic® cable trays

Installation principle



Ceiling mounting on both sides with max. three layers (2+1).

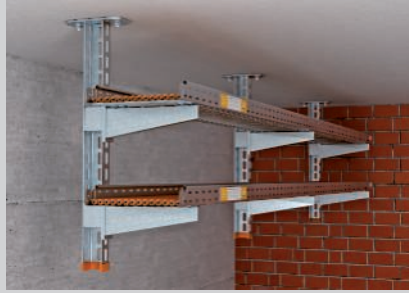

One-sided arrangement with max. two layers.



Wall mounting.



Creation of a straight connector through interconnection of the cable trays.



Bending the locking straps in the base.



Complete screwless joint connection.

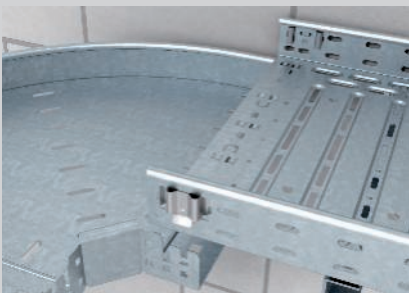

Quick and simple mounting of fitting with screwless Magic connection.



Separating retainer mounting with truss-head bolts.

Classification according to DIN 4102 Part 12

E30

E60

E90





RKS-Magic® cable trays

Proof

Maintenance of electrical functionality system according to DIN 4102 Part 12

Routing type	Cable-specific support construction
Test certificate no.	P-MPA-E-13-002
Maintenance of electrical functionality classes	E30 to E90
Testing standard	DIN 4102 Part 12
Mounting variant	Ceiling mounting with suspended support and bracket without threaded rod lock Wall mounting with bracket without threaded rod lock
Material version	Galvanised steel

Support spacing for ceiling mounting with suspended support/bracket

Cable tray width	Cable load per cable tray				
100 mm	max. 20 kg/m	max. 1.50 m	max. 1.50 m	max. 1.50 m	max. 1.50 m
200 mm	max. 20 kg/m	max. 1.50 m	max. 1.50 m	max. 1.50 m	max. 1.50 m
300 mm	max. 20 kg/m	max. 1.50 m	max. 1.50 m	max. 1.50 m	max. 1.50 m
400 mm	max. 20 kg/m	max. 1.50 m	max. 1.50 m	max. 1.50 m	max. 1.50 m





Support spacing for wall mounting with bracket

Cable tray width	Cable load per cable tray	
100 mm	max. 20 kg/m	max. 1.50 m
200 mm	max. 20 kg/m	max. 1.50 m
300 mm	max. 20 kg/m	max. 1.50 m
400 mm	max. 20 kg/m	max. 1.50 m

RKS-Magic® cable trays

Components used

Ceiling mounting with suspended support/bracket

Component	Type	Page				
Cable tray	RKSM 6... FS	48	1	2	2	3
Support	US 5 K ... FT		1	1	1	1
Protective cap	US 5 KS OR	51	1	1	1	1
Wall and support brackets	AW 30 11 FT, AW 55 21 FT, ... 31 FT, ... 41 FT		1	2	2	3
Spacer	DSK 45	52	1	2	1	2
Hex set screw	SKS 10x90 F	54	1	2	1	2
Fender washer	DIN440 11 F	55	1	2	0	1
Gutter bolt	FRSB 6x 15 F		2	4	4	6

Choose the fastening anchors according to the substrate

Wall mounting with bracket

Component	Type	
Cable tray	RKSM 6... FS	1
Wall and support brackets	AW 30 11 FT, AW 55 21 FT, ... 31 FT, ... 41 FT	1
Truss-head bolt	FRSB 6x 15 F	2

Choose the fastening anchors according to the substrate

RKS-Magic® cable trays

System description

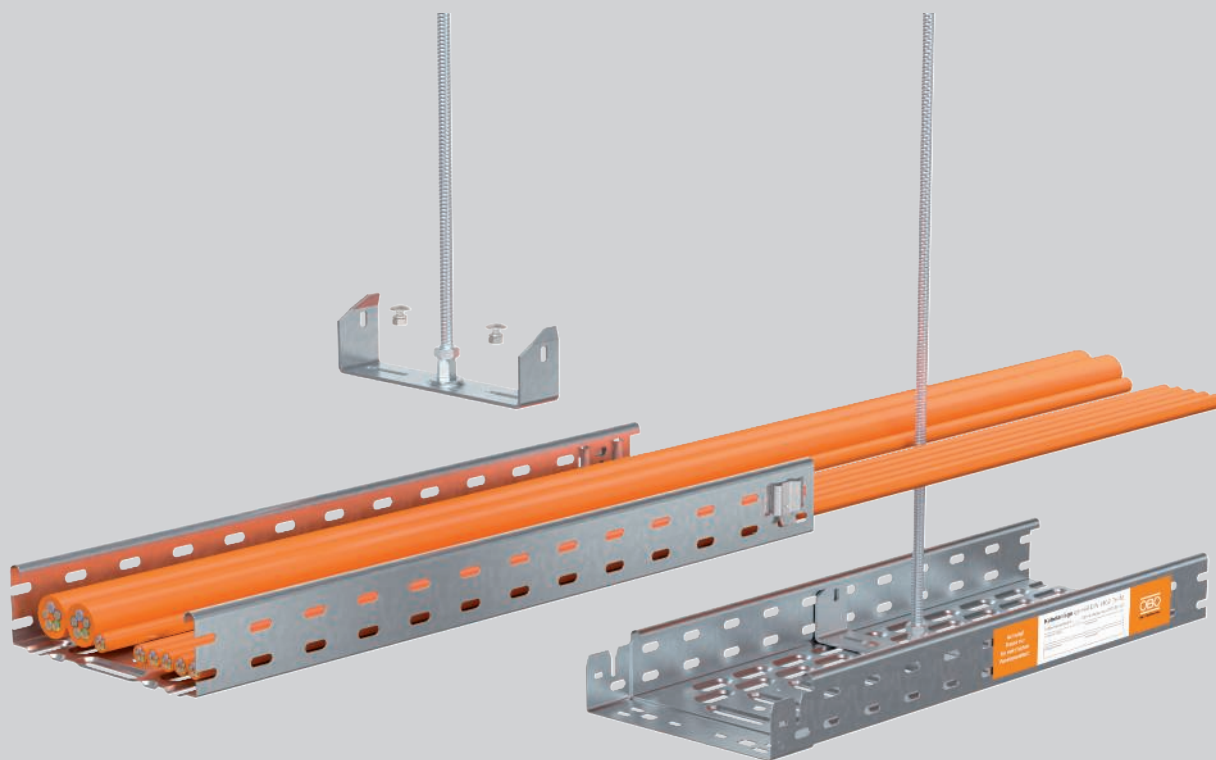

The RKS-Magic® cable tray has been tested as a cable-specific support construction for the maintenance of electrical functionality according to DIN 4102 Part 12 and approved for maintenance of electrical function classes E 30 to E 90. The support structure as a light-duty routing system consists of a centre suspension and a centrally arranged threaded rod as a suspension component and can be installed simply, quickly and with only a few components. The screwless

connection system allows interconnection of the RKS-Magic® cable trays without tools and in a particularly quick and economic manner. To ensure the maintenance of the electrical supply, only the locking lugs in the base need to be bent after the trays have been connected. The double material thickness in the joint area and the beading in the base mean that the cable tray has a very high load capacity. The installation of fittings in the section is permitted.

RKS-Magic® cable trays

Installation principle

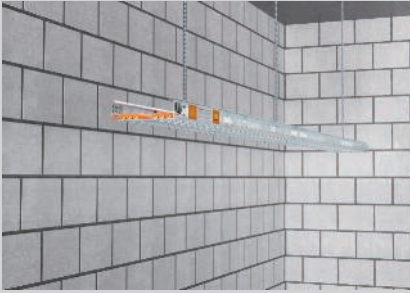

Single-layer ceiling mounting of the cable tray with a centre suspension.



Insertion of the centre suspension in the cable tray.



Securing of the threaded rod on the centre suspension with additional hexagonal nut.



Screwing of the centre suspension in the tray base.

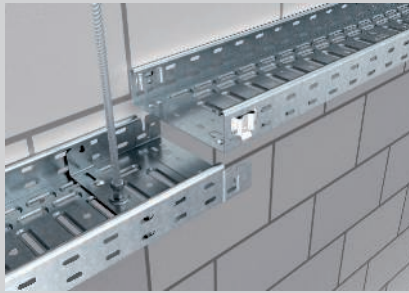

Creation of a straight connector through interconnection of the cable trays.



Bending the locking straps in the base.

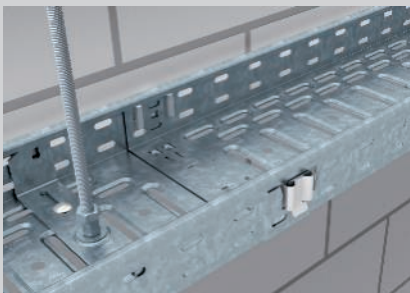

Complete screwless joint connection.



Quick and simple mounting of the fittings with screwless Magic connection.

Classification according to DIN 4102 Part 12

E30

E60

E90

RKS-Magic® cable trays

Proof

Maintenance of electrical functionality system according to DIN 4102 Part 12

Routing type	Cable-specific support construction
Test certificate no.	P-MPA-E-18-003
Maintenance of electrical functionality classes	E30 to E90
Testing standard	DIN 4102 Part 12
Mounting variant	Ceiling mounting with centre suspension
Material version	Galvanised steel

Support spacing for ceiling mounting with centre suspension

Cable tray width	Cable load per cable tray	
100 mm	max. 7.5 kg/m	max. 1.00 m
150 mm	max. 7.5 kg/m	max. 1.00 m
200 mm	max. 7.5 kg/m	max. 1.00 m

RKS-Magic® cable trays

Components used

Ceiling mounting with centre suspension

Component	Type	
Cable tray	RKSM 6... FS	1
Centre suspension	MAH 60 ... FS	1
Truss-head screw	FRSB 6x16	2
Threaded rod	TR M10 G	1
Hexagonal nut	HN M10 G	1

Choose the fastening anchors according to the substrate



GR-Magic® mesh cable trays

System description

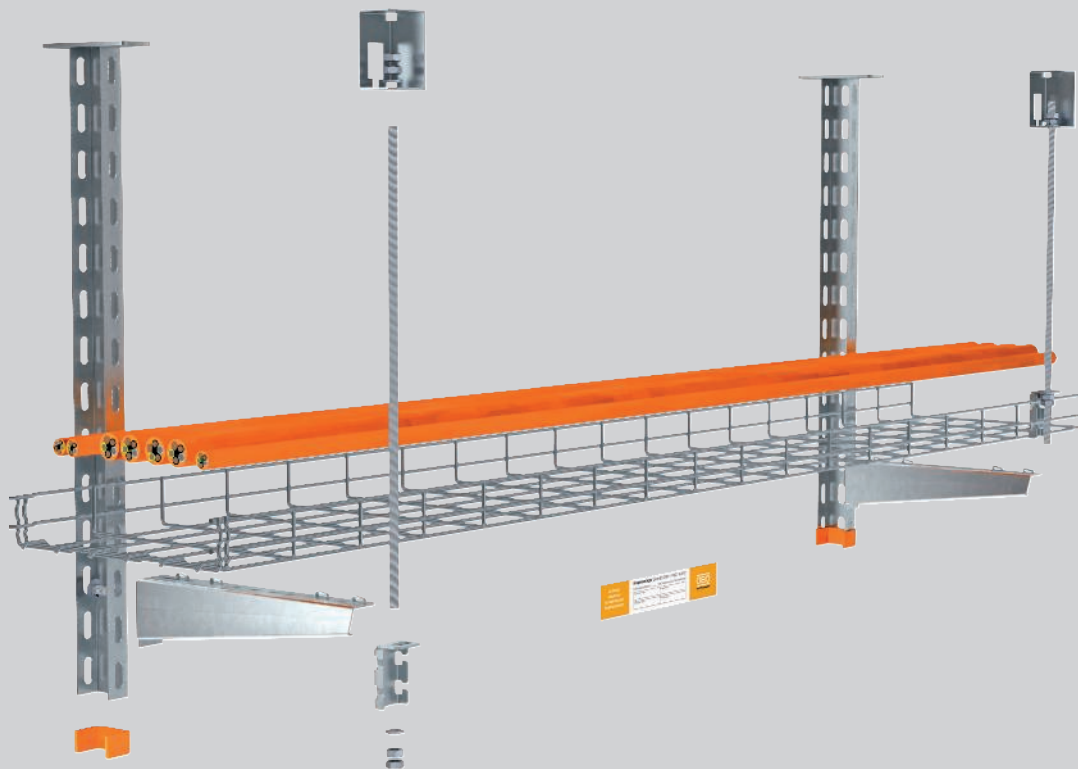

The GR-Magic® mesh cable tray has been tested as a cable-specific support construction for the maintenance of electrical function according to DIN 4102 Part 12 and approved for maintenance of electrical function classes E 30 to E 90. The threaded rod lock is mounted directly on the tray rail, using the ABG connection component. This is

just attached to the side lengthwise wires of the mesh cable tray. When the threaded rod has been mounted, the component is secured against unintentional release. The screwless connection system of the GR-Magic® mesh cable trays ensures toolless, and thus particularly rapid and economic, mounting.

GR-Magic® mesh cable trays

Installation principle



Ceiling mounting with brackets mounted on one side.

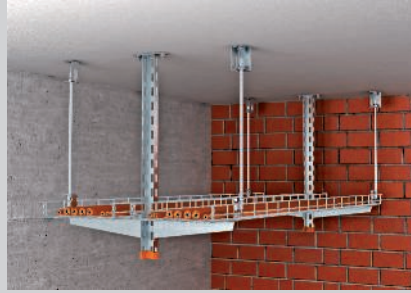

Ceiling mounting with brackets arranged on both sides.

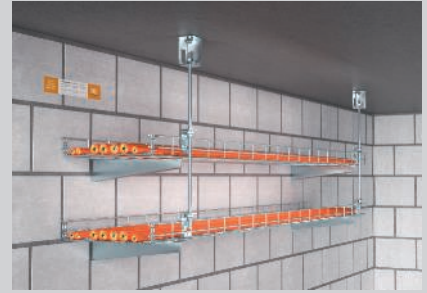

Multi-layer wall mounting.

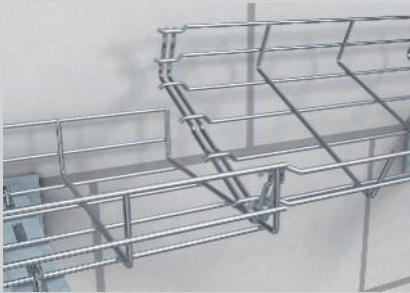

Interconnecting of two stock lengths of the mesh cable tray.

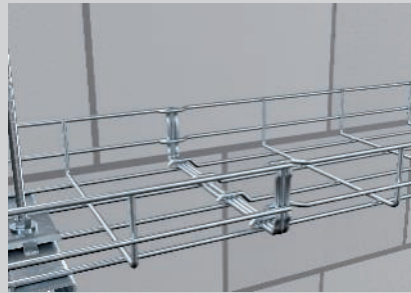

Finished screwless joint connection.



Screwless mesh cable tray fastening on the bracket.



Screwless fastening of the connection component to the side wires.

Classification according to DIN 4102 Part 12

E30

E60

E90





GR-Magic® mesh cable trays

Proof



Maintenance of electrical functionality system according to DIN 4102 Part 12

Routing type	Cable-specific support construction
Test certificate no.	P-MPA-E-12-011
Maintenance of electrical functionality classes	E30 to E90
Testing standard	DIN 4102 Part 12
Mounting variant	Ceiling mounting with suspended support and bracket with threaded rod lock Wall mounting with bracket and threaded rod lock
Material version	Galvanised steel

Support spacing for ceiling mounting with suspended support/bracket

Cable tray width	Cable load per cable tray					
100 mm	max. 15 kg/m	max. 1.50 m	max. 1.50 m	max. 1.50 m	max. 1.50 m	max. 1.50 m
200 mm	max. 15 kg/m	max. 1.50 m	max. 1.50 m	max. 1.50 m	max. 1.50 m	max. 1.50 m
300 mm	max. 15 kg/m	max. 1.50 m	max. 1.50 m	max. 1.50 m	max. 1.50 m	max. 1.50 m
400 mm	max. 15 kg/m	max. 1.50 m	max. 1.50 m	max. 1.50 m	max. 1.50 m	max. 1.50 m





Support spacing for wall mounting with bracket

Cable tray width	Cable load per cable tray			
100 mm	max. 15 kg/m	max. 1.50 m	max. 1.50 m	max. 1.50 m
200 mm	max. 15 kg/m	max. 1.50 m	max. 1.50 m	max. 1.50 m
300 mm	max. 15 kg/m	max. 1.50 m	max. 1.50 m	max. 1.50 m
400 mm	max. 15 kg/m	max. 1.50 m	max. 1.50 m	max. 1.50 m

GR-Magic® mesh cable trays



Components used

Ceiling mounting with suspended support/bracket

Component	Type					
Mesh cable tray	GRM 55 ... G	1	2	3	2	3
Support	US 3 K ... FT	1	1	1	1	1
Protective cap	US 3 KS OR	1	1	1	1	1
Wall and support brackets	AWG 15 ... FT	1	2	3	2	3
Truss-head bolt	FRS 10x 25 F	1	2	3	2	3
Connection component	ABG FT	1	2	3	2	3
Threaded rod	TR M10 G	1	2	0	2	3
Threaded rod	TR M12 G	0	0	3	0	0
Hexagonal nut	HN M10 G	4	5	0	8	9
Hexagonal nut	HN M12 G	0	0	6	0	0
Washer	WS M10 D20 G	2	3	0	4	5
Washer	WS M12 D24 G	0	0	4	0	0
Connection sleeve	CSTR M10 G	0	1	0	0	1
Connection sleeve	CSTR M12 G	0	0	2	0	0
Fire protection clamp	BSB	1	1	1	2	2

Choose the fastening anchors according to the substrate

Wall mounting with bracket

Component	Type			
Mesh cable tray	GRM 55 ... G	1	2	3
Wall and support brackets	AWG 15 ... FT	1	2	3
Connection component	ABG FT	1	2	3
Threaded rod	TR M10 G	1	2	0
Threaded rod	TR M12 G	0	0	3
Hexagonal nut	HN M10 G	4	5	0
Hexagonal nut	HN M12 G	0	0	6
Washer	WS M10 D20 G	2	3	0
Washer	WS M12 D24 G	0	0	4
Connection sleeve	CSTR M10 G	0	1	0
Connection sleeve	CSTR M12 G	0	0	2
Fire protection clamp	BSB	1	1	1

Choose the fastening anchors according to the substrate

GR-Magic® mesh cable tray, centre suspension System description

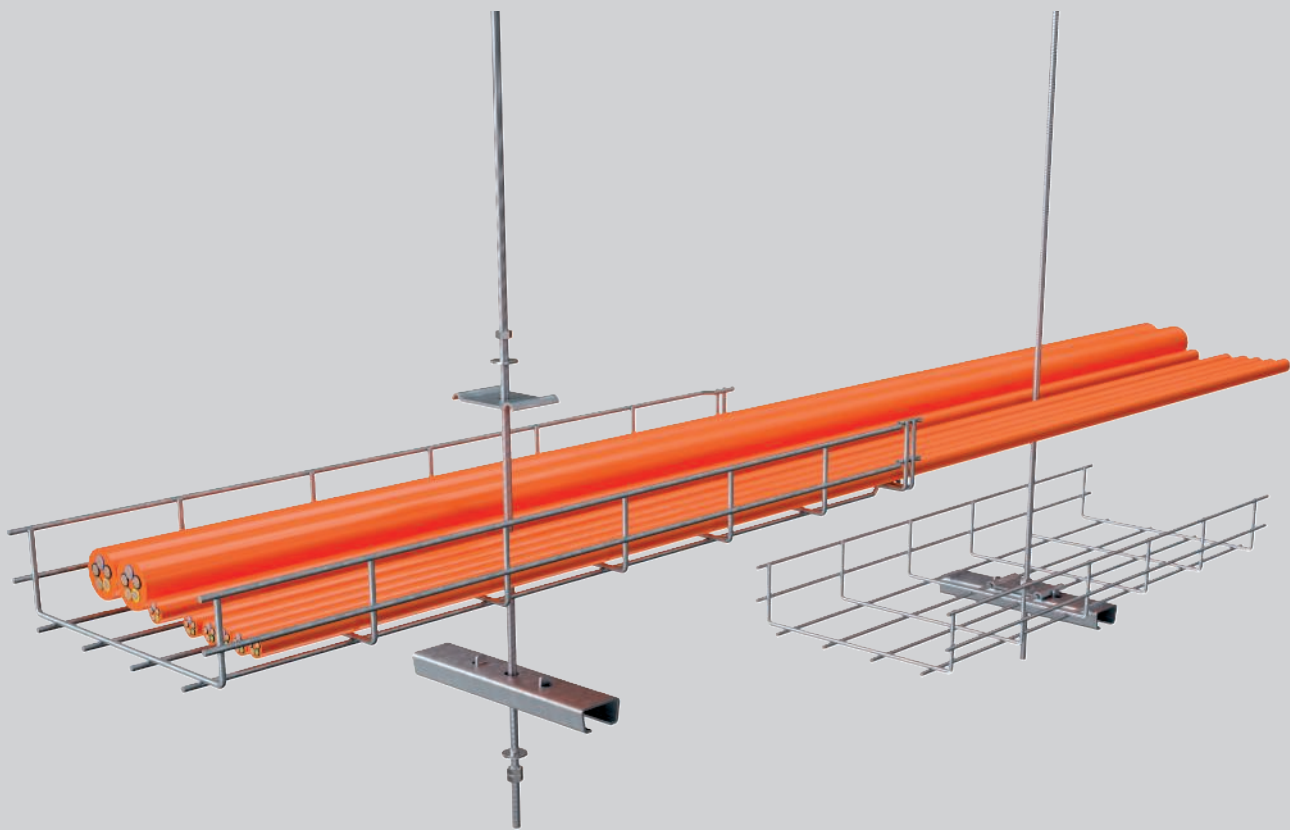

The GR-Magic® mesh cable tray has been tested as a cable-specific support construction for the maintenance of electrical functionality according to DIN 4102 Part 12 and approved for maintenance of electrical function classes E 30 to E 90. The support structure as a light-duty routing system consists of a centre suspension and a centrally

arranged threaded rod as a suspension component and can be installed simply, quickly and with only a few components. The screwless connection system of the GR-Magic® mesh cable trays ensures toolless, and thus particularly rapid and economic, mounting.

GR-Magic® mesh cable trays

Installation principle



Single-layer ceiling mounting of the mesh cable tray with a centre suspension.

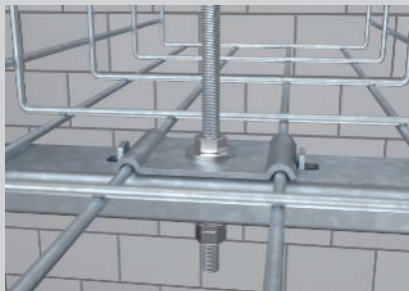

Positioning and fastening of the clamping piece with the threaded rod.



Connection of the threaded rod with the retaining rail under the mesh cable tray.

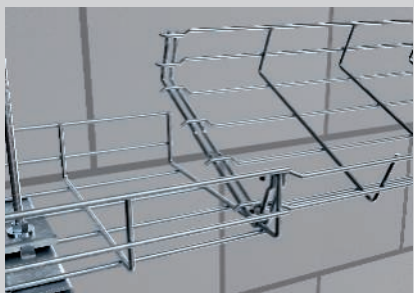

Interconnection of two stock lengths of the mesh cable tray.



Complete screwless joint connection.

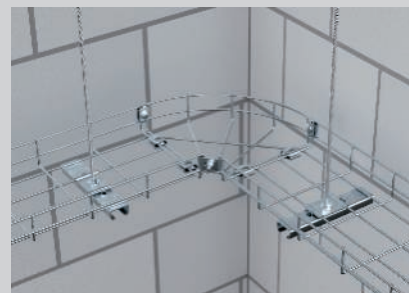

Mounting of fittings with joint connector.

Classification according to DIN 4102 Part 12

E30

E60

E90

GR-Magic® mesh cable trays

Proof

Maintenance of electrical functionality system according to DIN 4102 Part 12

Routing type	Cable-specific support construction
Test certificate no.	P-MPA-E-18-004
Maintenance of electrical functionality classes	E30 to E90
Testing standard	DIN 4102 Part 12
Mounting variant	Ceiling mounting with centre suspension
Material version	Galvanised steel

Support spacing for ceiling mounting with centre suspension

Mesh cable tray width	Cable load per mesh cable tray	
200 mm	max. 7.5 kg/m	max. 1.0 m

GR-Magic® mesh cable trays

Components used

Ceiling mounting with centre suspension

Component	Type	
Mesh cable tray	GRM 55 200 G	1
Centre suspension	GMS 170 FS	1
Threaded rod	TR M10 G	1
Hex nut	HN M10 G	3
Washer	WS 10 G	1
Fender washer	DIN440 11 F	1

Choose the fastening anchors according to the substrate



Cable tray RKS-Magic® 60

St FS FT



Type	Width mm	Metal thick- ness mm	BS	Pack m	Weight kg/100 m	Item no.
RKSM 610 FS	100	0.75	🔥	3	134.334	6047611
RKSM 615 FS	150	0.75	🔥	3	154.885	6047630
RKSM 620 FS	200	0.75	🔥	3	181.508	6047638
RKSM 630 FS	300	0.75	🔥	3	233.803	6047654
RKSM 640 FS	400	0.90	🔥	3	338.459	6047689
RKSM 610 FT	100	1.00	🔥	3	197.410	6047612
RKSM 620 FT	200	1.00	🔥	3	251.115	6047639
RKSM 630 FT	300	1.00	🔥	3	356.295	6047655
RKSM 640 FT	400	1.00	🔥	3	437.180	6047690

Cable tray with integrated quick fastening system. The usable length of the cable tray is 3,000 mm. The cable tray has continuous side perforations of 7 x 20 mm for the installation of additional connection and mounting components. The perforation for direct threaded rod suspension has a diameter of 11 mm.

Type	Length mm	Usable Dim. B mm	cross- section cm ²	Dim. x y mm	Dim- en- sion mm
RKSM 610 FS	3050	100	58	—	50
RKSM 615 FS	3050	150	88	50	100
RKSM 620 FS	3050	200	118	100	150
RKSM 630 FS	3050	300	178	200	250
RKSM 640 FS	3050	400	238	300	350

Dimensions

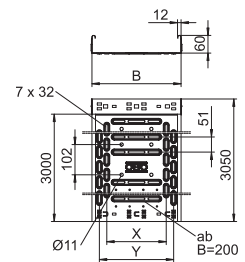

90° Magic bend 60

St FS FT

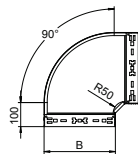
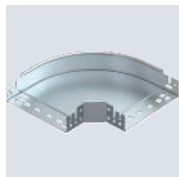

Type	Width mm	Dim. B mm	Pack Piece	Weight kg/100 pc.	Item no.
RBM 90 610 FS	100	100	1	65.700	6041130
RBM 90 610 FT	100	100	1	70.700	6041150

90° bend with quick connector system. For all cable tray types of 60 mm side height.

Add-on tee 60

St FS

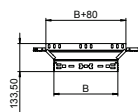
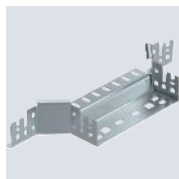

Type	Width mm	Dim. B mm	Pack Piece	Weight kg/100 pc.	Item no.
RAAM 630 FS	300	300	1	60.940	6041236

Magic add-on tee with quick connector system. For all cable tray types of 60 mm side height.

St FS DD

Magic straight connector set 60

Type	Width mm	Side height mm	Dim. B mm	Pack Piece	Weight kg/100 pc.	Item no.
KTSMV 610 FS	100	60	100	1	30.500	6068914
KTSMV 610 DD	100	60	100	1	30.500	6068936

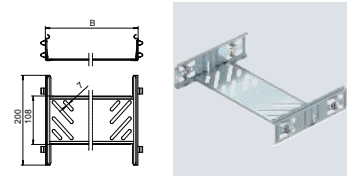

Cable tray connector with quick fastening for the screwless connection of perforated cable trays with a side height of 60 mm.

St FS FT

Centre suspension for cable tray, 60

Type	for width mm	For threaded rod	Dim. B mm	Dim. b mm	F in kN	Pack Piece	Weight kg/100 pc.	Item no.
MAH 60 100 FS	100	M10	94	84	1.3	1	17.250	6358705
MAH 60 200 FS	200	M10	195	184	0.2	1	24.500	6358713
MAH 60 100 FT	100	M10	94	84	1.3	1	18.500	6358752
MAH 60 150 FT	150	M10	144	134	0.5	1	23.000	6358756
MAH 60 200 FT	200	M10	195	184	0.2	1	27.600	6358760

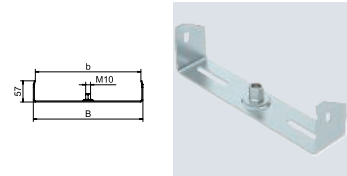

The centre suspension possesses a rotatable M10 threaded sleeve. When filling, ensure an even distribution of the load (avoid one-sided filling).
The widths 100, 150 and 200 mm have additional base perforations, in order to screw the centre suspensions to the tray base when used for the maintenance of electrical functionality according to DIN 4102 Part 12.
Centre suspension for cable trays with rolled side rail of side height 60 mm.

Mesh cable tray GR-Magic®

St G

GR-Magic® 55 mesh cable tray

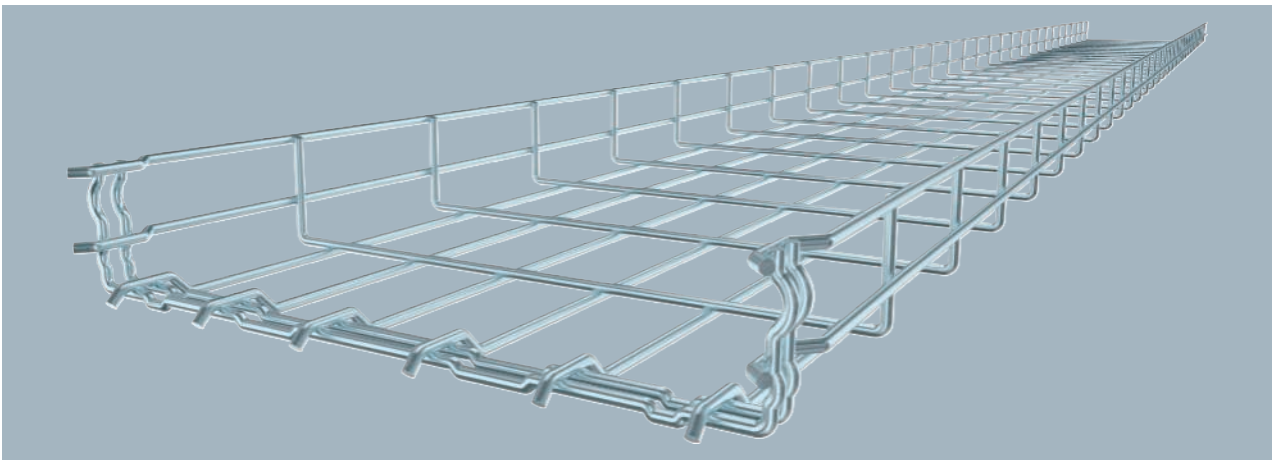

Mesh cable tray with shaped connector of side height 55 mm.

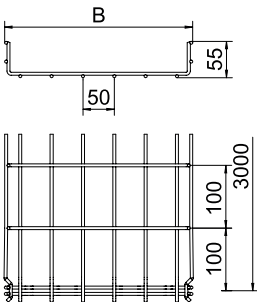

Type	Width mm	Wire Ø mm	BS	Pack m	Weight kg/100 m	Item no.
GRM 55 50 G	50	3.9		3	67.000	6001441
GRM 55 100 G	100	3.9	🔥	3	72.000	6001442
GRM 55 150 G	150	3.9		3	85.667	6001444
GRM 55 200 G	200	3.9	🔥	3	100.667	6001446
GRM 55 300 G	300	4.8	🔥	3	192.333	6001448
GRM 55 400 G	400	4.8	🔥	3	234.667	6001450
GRM 55 500 G	500	4.8		3	276.667	6001452
GRM 55 600 G	600	4.8		3	320.000	6001454

Mesh cable tray GR-Magic®

Protective caps

PVC

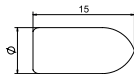

Type	Colour	Pack Piece	Weight kg/100 pc.	Item no.
GR KS 3.9 OR	Pure orange	500	0.045	6003750
GR KS 4.8 OR	Pure orange	500	0.030	6003754

Protective cap to cover cut wire ends of mesh cable trays.

GKS 34 hold-down clamp

St G

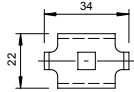

Type	Pack Piece	Weight kg/100 pc.	Item no.
GKS 34 G	20	2.188	6016855

Clamp for fixing mesh cable trays to wall or support brackets.

Joint connector GSV 34

St G

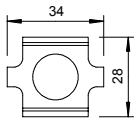

Type	Pack Piece	Weight kg/100 pc.	Item no.
GSV 34 G	20	3.155	6016596

Screwed version of joint connector for mesh cable trays.

Centre suspension mesh cable tray

St FS

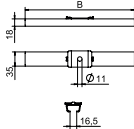

Type	Dim. B mm	Pack Piece	Weight kg/100 pc.	Item no.
GMS 170 FS	170	25	20.000	6015400

Centre suspension including hold-down clamp for mesh cable tray suspensions.

Mounting systems

US 3 support

St FT



Type	Length mm	Material thickness mm	BS	Pack Piece	Weight kg/100 pc.	Item no.
US 3 K 20 FT	200	2	🔥	1	50.500	6342351
US 3 K 30 FT	300	2	🔥	1	64.400	6342353
US 3 K 40 FT	400	2	🔥	1	78.300	6342355
US 3 K 50 FT	500	2	🔥	1	92.300	6342357
US 3 K 60 FT	600	2	🔥	1	106.200	6342359
US 3 K 70 FT	700	2	🔥	1	120.200	6342362
US 3 K 80 FT	800	2	🔥	1	134.100	6342364
US 3 K 90 FT	900	2	🔥	1	147.800	6342366
US 3 K 100 FT	1000	2	🔥	1	162.000	6342368
US 3 K 110 FT	1100	2	🔥	1	175.900	6342370
US 3 K 120 FT	1200	2	🔥	1	189.900	6342372

Suspended support (U profile) of dimensions 50 x 30 mm with welded head plate.

US 7 support

St FT

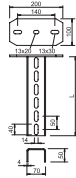

Type	Length mm	Material thickness mm	BS	Pack Piece	Weight kg/100 pc.	Item no.
US 7 K 90 FT	900	4		1	470.000	6339166
US 7 K 120 FT	1200	4		1	591.000	6339204

Suspended support (U profile) of dimensions 70 x 50 mm with welded head plate.

End cap

PE

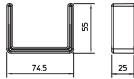

Type	Colour	Pack Piece	Weight kg/100 pc.	Item no.
US 7 KS OR	Pastel orange	20	1.806	6338497

Protective cap to cover the ends of US 7 supports.

Spacer DSK 45

St FT

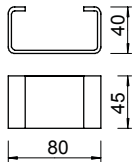

Type	Pack Piece	Weight kg/100 pc.	Item no.
DSK 45 FT	20	18.000	6416500

Spacer for use in US 5 support and in the head plate, type KU 7 VQP.

DSK 61 spacer

St FT

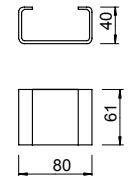

Type	Pack Piece	Weight kg/100 pc.	Item no.
DSK 61 FT	20	25.000	6416519

Spacer for use in US 7 supports.

Wall and support bracket AW 15

St FT

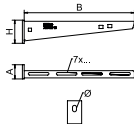

Type	Width mm	Dim. H mm	Dim. A mm	Dim. B mm	Hole Ø mm	BS	Pack Piece	Weight kg/100 pc.	Item no.
AW 15 21 FT	210	60	40	210	11		1	24.000	6420680
AW 15 31 FT	310	65	40	310	11		1	38.400	6420710
AW 15 41 FT	410	70	40	410	11		1	54.000	6420745

Light-duty wall and support bracket with welded head plate.

St FT

Wall and support bracket AWG 15

Type	Width mm	Dim. H mm	Dim. A mm	Dim. B mm	Hole Ø mm	BS	Pack Piece	Weight kg/100 pc.	Item no.
AW G 15 21 FT	210	60	40	210	11		1	26.000	6420608
AW G 15 31 FT	310	65	40	310	11		1	35.000	6420610
AW G 15 41 FT	410	70	40	410	11		1	56.000	6420612

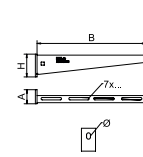

Light-duty wall and support bracket with welded head plate for screwless mesh cable tray fastening.

St G

Threaded rod

Type	Thread	Dim. d mm	Dim. L mm	Pack Piece	Weight kg/100 pc.	Item no.
TR M10 1M G	M10	10	1000	10	49.000	3141209

Threaded rod to DIN 976.

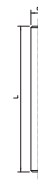

St G

Connection sleeve

Type	Thread	Dim. L mm	SW mm	Pack Piece	Weight kg/100 pc.	Item no.
CSTR M10 G	M10	30	17	50	4.150	6410103
CSTR M12 G	M12	40	19	25	7.000	6410111

Connection sleeve with continuous internal thread.

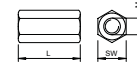

St FS

Separating retainer 45

Type	Dim. H mm	Metal thick- ness mm	Dim. L mm	Pack m	Weight kg/100 m	Item no.
TSG 45 FS	45	0.75	3000	3	46.700	6062033

Separating retainer for separation of cables of different voltages or functions.

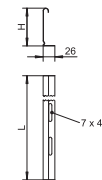

VA 2B

Separating retainer connector

Type	Pack Piece	Weight kg/100 pc.	Item no.
TSGV A2	10	0.899	6067970

Separating retainer connector for screwless connection of the TSG separating retainer in all side heights.

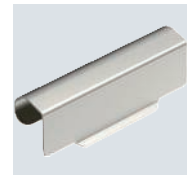
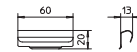

Hold-down clamp for separating retainer fastening in RKSM

VA 2B

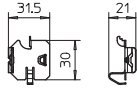
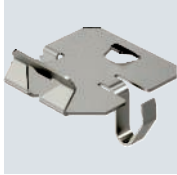

Type	Pack Piece	Weight kg/100 pc.	Item no.
KS KR A2	30	0.537	6062280

Hold-down clamp for screwless fastening of separating retainers in the cable tray types RKSM, MKS and SKS.

Hold-down clamp for separating retainer fastening in GRM

VA 2B

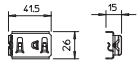

Type	Pack Piece	Weight kg/100 pc.	Item no.
KS GR A2	30	0.830	6062282

Hold-down clamp for fastening separating retainer in mesh cable trays.

Hexagonal bolt M10

St F

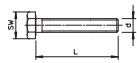

Type	Dimension mm	Dim. L mm	Dim. d mm	Dim. SW mm	Resistance grade	Pack Piece	Weight kg/100 pc.	Item no.
SKS 10x80 F	M 10x80	80	10	17	8.8	20	6.900	6418250
SKS 10x90 F	M 10x90	90	10	17	8.8	20	8.950	6418252

Hexagonal bolt for universal fastening of construction components. With hexagonal nut and 2 washers.

Truss-head bolt with flange nut

St F

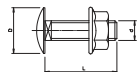
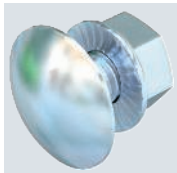

Type	Dimension mm	Dim. L mm	Dim. d mm	Dim. D mm	Resistance grade	Pack Piece	Weight kg/100 pc.	Item no.
FRSB 6x12 F	M 6x12	12	6	13.5	5.6	100	0.812	6406122
FRSB 6x20 F	M 6x20	20	6	13.5	5.6	100	0.965	6406203

Truss-head bolt with square neck including flange nut.

Truss-head bolt with nut and washer

St F

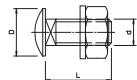
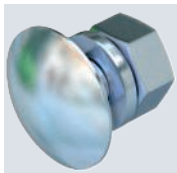

Type	Dimension mm	Dim. L mm	Dim. d mm	Dim. D mm	Resistance grade	Pack Piece	Weight kg/100 pc.	Item no.
FRS 10x25 F	M 10x25	25	10	24	5.6	50	4.077	6407528

Truss-head bolt with square neck. With washer and hexagonal nut.

St F

Large washer

Type	Dim. D mm	Dim. d mm	Dim. h mm	Pack Piece	Weight kg/100 pc.	Item no.
DIN440 11 F	34	11	3	100	1.852	6408729

Washer of particularly large outer diameter.

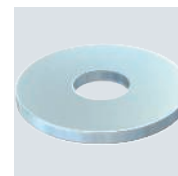
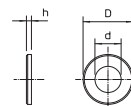

St G

Washer

Type	Thread	Dim. d mm	Dim. D mm	Dim. h mm	Pack Piece	Weight kg/100 pc.	Item no.
WS M10 D20 G	M10	10.5	20	2	100	0.408	3402096

Washer according to DIN 125, shape A, for universal use.

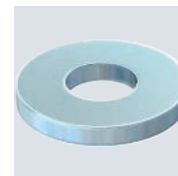
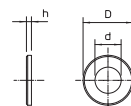

RKS-Magic® cable tray, stainless steel

Systems for the maintenance of electrical function, cable-specific routing variants

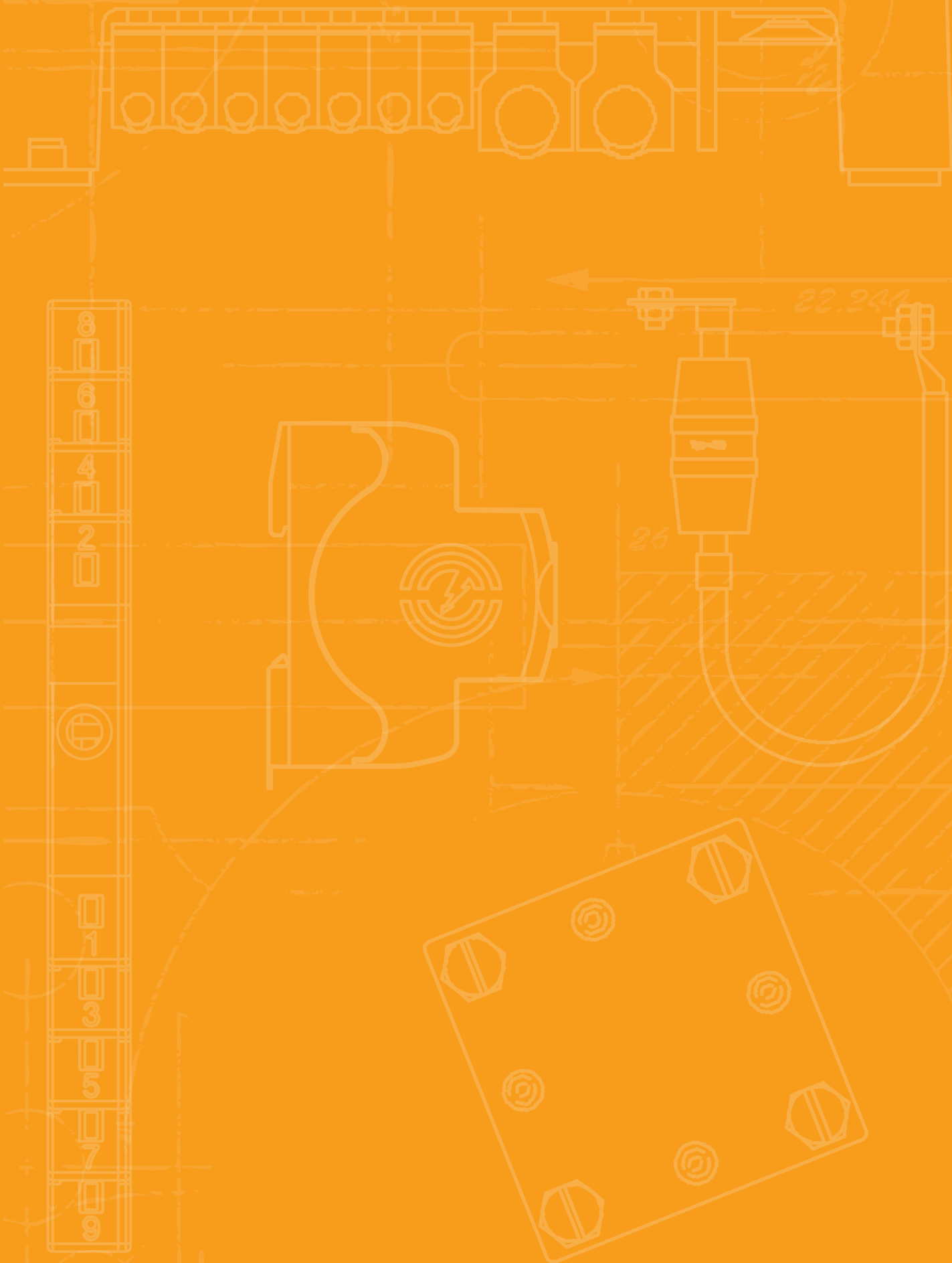

Cable trays, RKS-Magic® VA System description

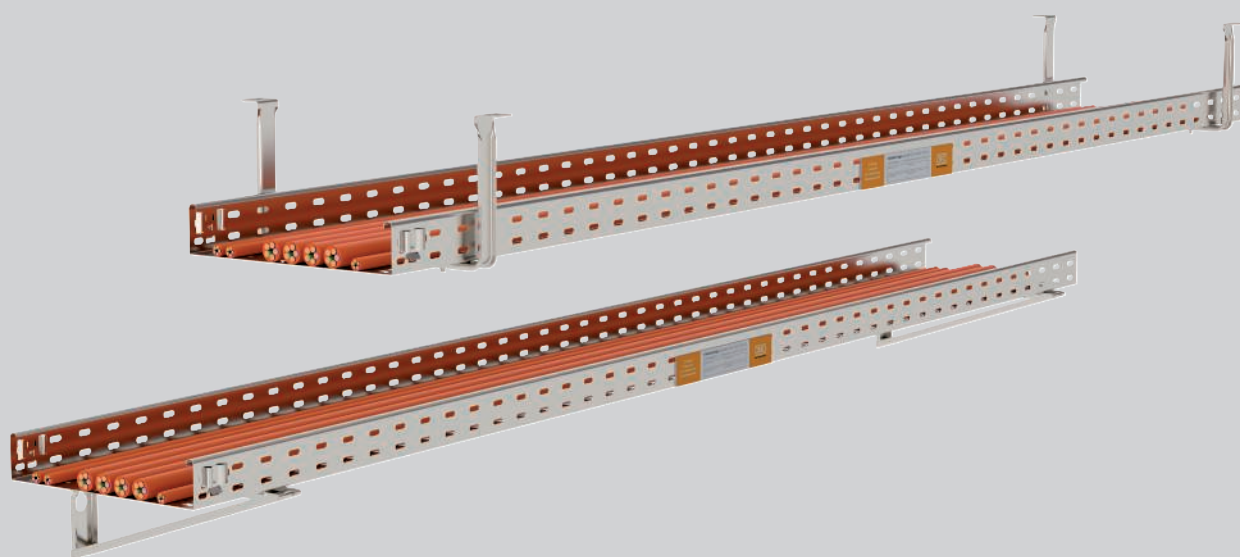

The RKS-Magic® cable tray has been tested as a cable-specific support construction for the maintenance of electrical function according to DIN 4102 Part 12 and approved for maintenance of electrical function classes E 30 to E 90. The screwless connection system allows interconnection of the RKS-Magic® cable trays without tools and in a particularly quick and economic manner. To ensure the maintenance of

the electrical supply, only the locking lugs in the base need to be bent after the trays have been connected. The double material thickness in the joint area and the beading in the base mean that the cable tray has a very high load capacity. The installation of fittings in the section route is permitted, as is the mounting of separating retainers.

Cable trays, RKS-Magic® VA

Installation principle



Single-layer ceiling mounting with suspension clamp.



Mounting under sloping ceiling with individually adapted suspension clamp.



Two-layer ceiling mounting with suspension clamp and intermediate clamp.

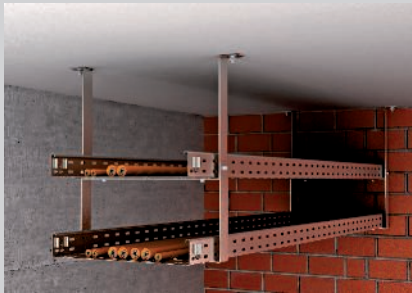

Two-layer ceiling mounting with suspension clamp and extension.



Fastening of the cable tray with truss-head bolts.



Joint connection without additional gland.

Classification according to DIN 4102 Part 12

E30

E60

E90



Cable trays, RKS-Magic® VA

Proof

Maintenance of electrical functionality system according to DIN 4102 Part 12

Routing type	Cable-specific support construction
Test certificate no.	P-MPA-E-12-003
Maintenance of electrical functionality classes	E30 to E90
Testing standard	DIN 4102 Part 12
Mounting variant	Ceiling mounting with suspension clamp
Material version	Rustproof steel

Support spacing for ceiling mounting with suspension clamp



Cable tray width	Cable load per cable tray		
100 mm	max. 30 kg/m	max. 1.50 m	max. 1.50 m
200 mm	max. 30 kg/m	max. 1.50 m	max. 1.50 m
300 mm	max. 30 kg/m	max. 1.50 m	max. 1.50 m



Cable trays, RKS-Magic® VA

Components used

Ceiling mounting with suspension clamp

Component	Type		
Cable tray	RKSM 6... VA4571	1	2
Suspension clamp	AHB-T	1	1
Truss-head bolt	FRSB 6x12 A4	2	4
Intermediate clamp	AHB-TZ	0	1
Truss-head bolt	FRSB 6x16 A4	0	2

Choose the fastening anchors according to the substrate
Intermediate clamp AHB-TZ on request

GR-Magic® mesh cable trays VA

System description

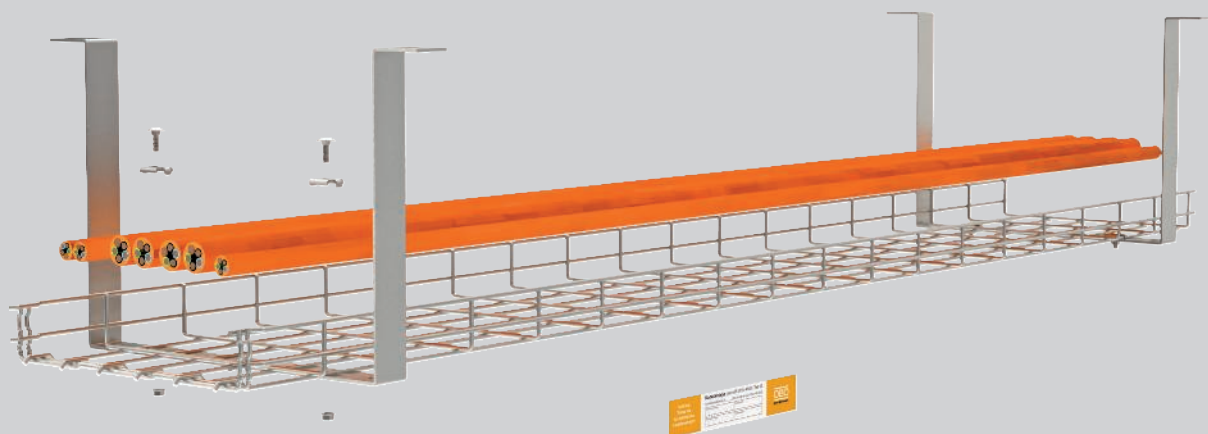

The GR-Magic® mesh cable tray, made from rustproof steel, has been tested as a cable-specific support structure for the maintenance of electrical function according to DIN 4102 Part 12 and approved for the maintenance of electrical function classes E 30 to E 90. The rustproof steel version permits mounting in areas with more aggressive ambient conditions. The design of the AHB-T suspension clamp means that it can be mounted on straight, slanted or curved ceilings, thus

allowing simple, space-saving installation of the mesh cable tray. The benefits of the screwless connection systems of the GR-Magic® mesh cable trays also apply to this routing type. This makes mounting of mesh cable trays, for example in the installation of long sections in increased corrosion protection requirements, an economically viable routing variant. With this system, the mounting of separating retainers and lids is permitted.

GR-Magic® mesh cable trays VA

Installation principle



Single-layer ceiling mounting with suspension clamp.



Mounting under sloping ceiling with individually adapted suspension clamp.

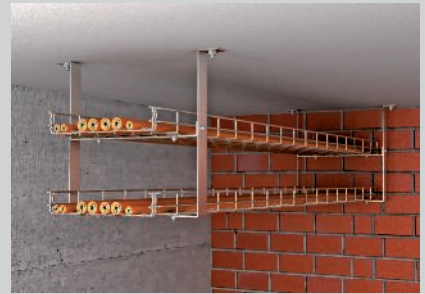

Two-layer ceiling mounting with suspension clamp and intermediate clamp.

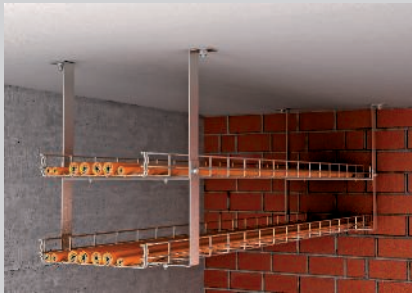

Two-layer ceiling mounting with suspension clamp and extension.

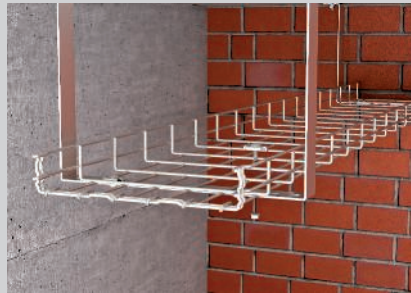

Fastening of the mesh cable tray with clamping piece and truss-head bolts.

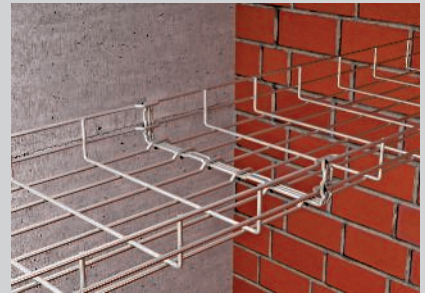

Joint connection without additional gland.

Classification according to DIN 4102 Part 12

E30

E60



E90

GR-Magic® mesh cable trays VA Proof

Maintenance of electrical functionality system according to DIN 4102 Part 12

Routing type	Cable-specific support construction
Test certificate no.	P-MPA-E-12-003
Maintenance of electrical functionality classes	E30 to E90
Testing standard	DIN 4102 Part 12
Mounting variant	Ceiling mounting with suspension clamp
Material version	Rustproof steel

Support spacing for ceiling mounting with suspension clamp



Cable tray width	Cable load per cable tray		
100 mm	max. 20 kg/m	max. 1.50 m	max. 1.50 m
200 mm	max. 20 kg/m	max. 1.50 m	max. 1.50 m
300 mm	max. 20 kg/m	max. 1.50 m	max. 1.50 m



GR-Magic® mesh cable trays VA

Components used

Ceiling mounting with suspension clamp

Component	Type		
Mesh cable tray	GRM 55 ... VA4401	1	2
Suspension clamp	AHB-T	1	1
Clamping piece	GKS 34 VA4401	2	4
Intermediate clamp	AHB-TZ	0	1
Truss-head bolt	FRSB 6x16 A4	0	2

Choose the fastening anchors according to the substrate
Intermediate clamp AHB-TZ on request

A2 A4 2B

Cable tray RKS-Magic® 60

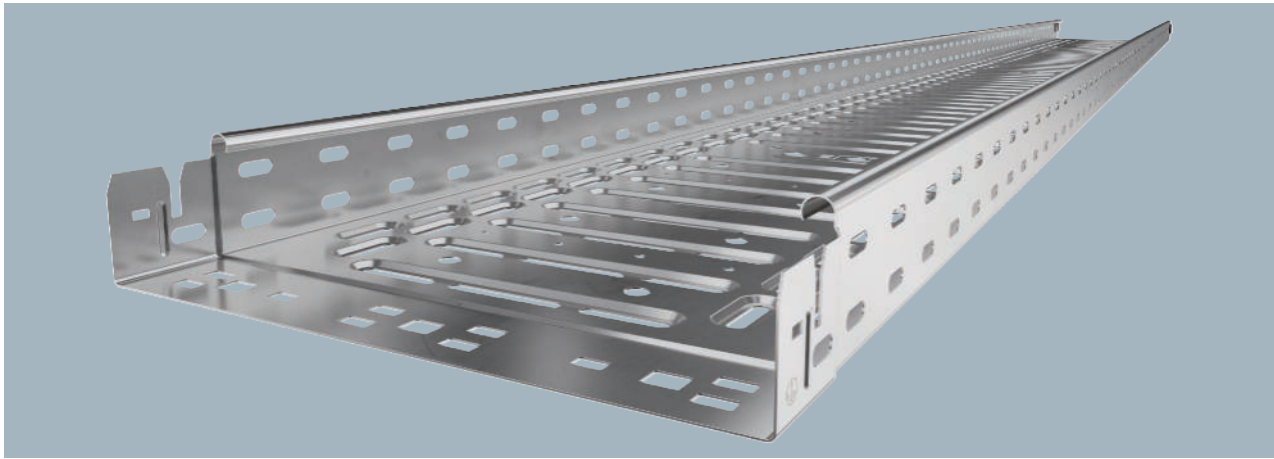

Cable tray with integrated quick fastening system. The usable length of the cable tray is 3,000 mm. The cable tray has continuous side perforations of 7 x 20 mm for the installation of additional connection and mounting components. The perforation for direct threaded rod suspension has a diameter of 11 mm.

Type	Width mm	Metal thickness mm	BS	Pack m	Weight kg/100 m	Item no.
RKSM 620 A2	200	0.75		3	200.984	6047640
RKSM 630 A2	300	0.75		3	259.344	6047656
RKSM 610 A4	100	0.75		3	144.590	6047614
RKSM 620 A4	200	0.75		3	200.984	6047641
RKSM 630 A4	300	0.75		3	259.344	6047657

Dimensions

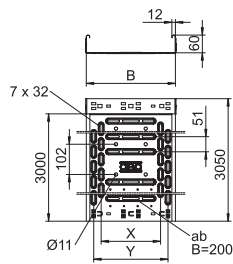

Type	Length mm	Width mm	Usable cross-section cm²	Dim. x mm	Dim. y mm
RKSM 620 A2	3050	200	118	100	150
RKSM 630 A2	3050	300	178	200	250

Mesh cable tray GR-Magic® VA

PVC

Protective caps

Type	Colour	Pack Piece	Weight kg/100 pc.	Item no.
GR KS 4.8 OR	Pure orange	500	0.030	6003754

Protective cap to cover cut wire ends of mesh cable trays.

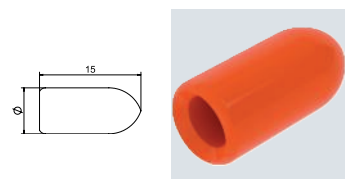

A2 VA 2B

GKS 34 hold-down clamp

Type	Pack Piece	Weight kg/100 pc.	Item no.
GKS 34 A2	20	2.000	6016839
GKS 34 A4	10	1.976	6016859

Hold-down clamp for fixing mesh cable trays to wall or support brackets.

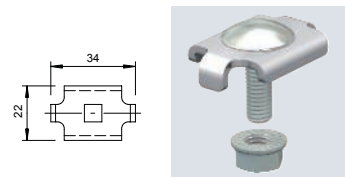

Joint connector GSV 34

A2 VA 2B

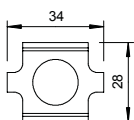

Type	Pack Piece	Weight kg/100 pc.	Item no.
GSV 34 A2	20	2.572	6016642
GSV 34 A4	20	3.000	6016648

Screwed version of joint connector for mesh cable trays.

Mounting systems, VA

Separating retainer connector

VA 2B



Type	Pack Piece	Weight kg/100 pc.	Item no.
TSGV A2	10	0.899	6067970

Separating retainer connector for screwless connection of the TSG separating retainer in all side heights.

Hold-down clamp for separating retainer fastening in RKSM

VA 2B

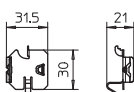
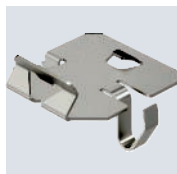

Type	Pack Piece	Weight kg/100 pc.	Item no.
KS KR A2	30	0.537	6062280

Hold-down clamp for screwless fastening of separating retainers in the cable tray types RKSM, MKS and SKS.

Hold-down clamp for separating retainer fastening in GRM

VA 2B

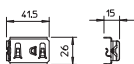

Type	Pack Piece	Weight kg/100 pc.	Item no.
KS GR A2	30	0.830	6062282

Hold-down clamp for fastening separating retainer in mesh cable trays.

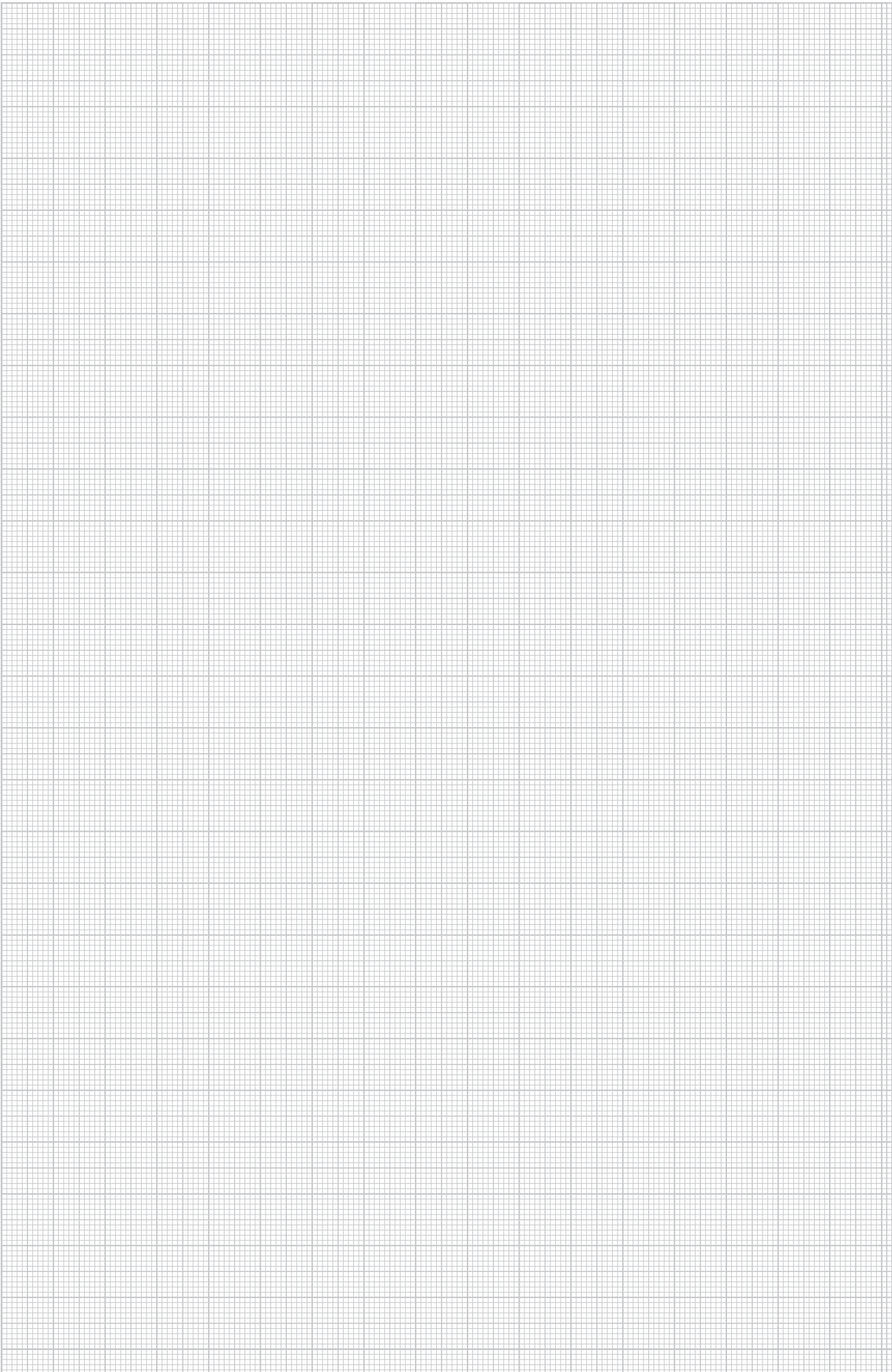



Systems for the maintenance of electrical function, fire-tested individual routing systems



Steel pipes

70



Clamp clips, profile rails and screw-in spacer clips

74



Cable routing in pipes

System description

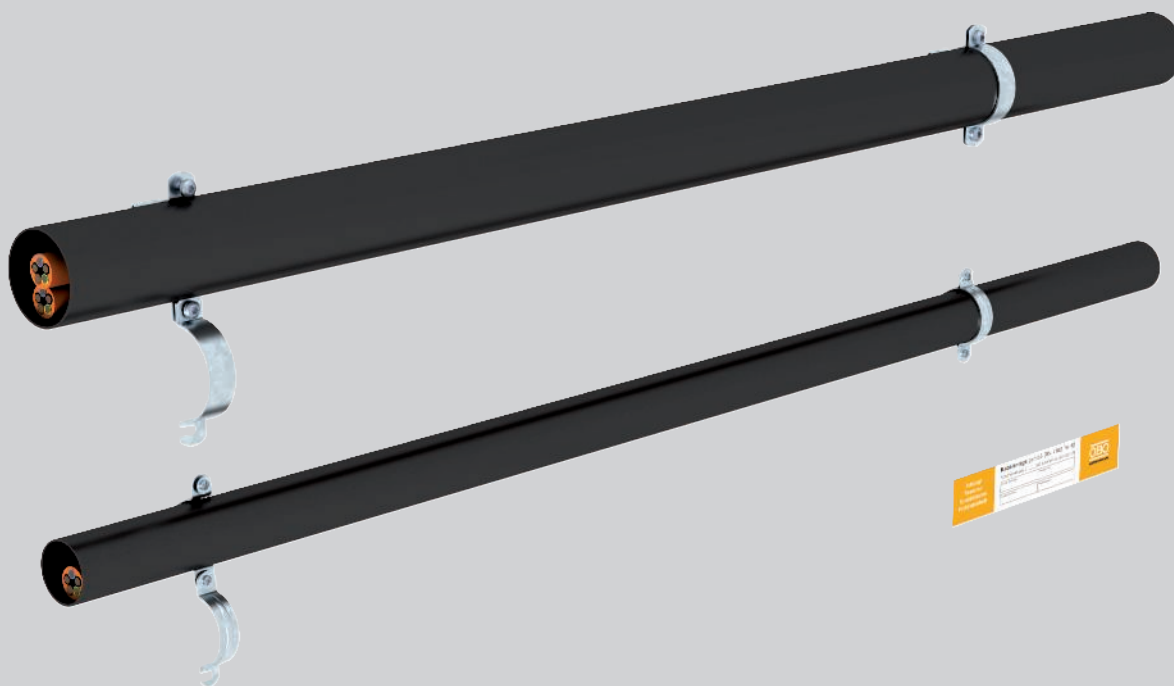

Cable routing in the steel pipe, in combination with clamp clips or with screw-in spacer clips, fulfils the requirements of DIN 4102 Part 12 as a cable-specific routing type for the maintenance of electrical functionality classes E 30, E 60 and E 90. The steel pipes may be routed horizontally on the wall or under the ceiling and offer additional mechanical protection of the installed cables. Sheet

steel clamp clips are used together with a riveted metal pressure sleeve and the appropriate profile rails, or closed screw-in spacer clips made of galvanised sheet steel. Refer to the available test certificates of the cable manufacturer for the maximum possible dimensions of the pipes, the maximum fastening spacing of the clips and the number of cables to be run in the pipe.

Cable routing in pipes

Installation principle



Ceiling mounting with screw-in spacer clip and clamp clip.



Horizontal wall mounting with screw-in spacer clip and clamp clip.



Space-saving installation of multiple pipes next to one another with clamp clips.



Insertion into the screw-in spacer clip by hooking the cover under the screw.



Multiple assignment according to the data of the test reports.

Classification according to DIN 4102 Part 12

E30

E60

E90

System description

Routing type	Cable-specific support structure
Maintenance of electrical function classes	E30 to E90
Testing standard	DIN 4102 Part 12

Approved data

Cable-specific	Cable types and mounting parameters dependent on the cable manufacturer
----------------	---

The data in the general construction test certificates applies.

Armoured steel pipe without thread, black

St PE50



4 | 4 | 5 | 6 | 1

Type	Dim. D mm	Dim. L mm	Dim. t mm	Colour	Pack m	Weight kg/100 m	Item no.
S16W SW	16	3000	1	Jet black	30	37.000	2046565
S20W SW	20	3000	1	Jet black	30	44.700	2046566
S25W SW	25	3000	1.2	Jet black	30	70.400	2046567
S32W SW	32	3000	1.2	Jet black	21	91.200	2046568
S40W SW	40	3000	1.2	Jet black	15	139.700	2046569
S50W SW	50	3000	1.2	Jet black	15	176.000	2046570
S63W SW	63	3000	1.2	Jet black	9	223.000	2046571

Electrical installation pipe without threaded ends according to EN 61386-1 for mechanical protection of cables. With burr-free inner wall.

Armoured steel pipe connection sleeve without thread, black

St PE50



Type	Dim. D mm	Dim. d mm	Dim. L mm	Dim. l mm	Dim. t mm	Colour	Pack Piece	Weight kg/100 pc.	Item no.
SV16W SW	18.6	16.6	50	25	1	Jet black	25	2.400	2046582
SV20W SW	23.1	20.7	60	30	1.2	Jet black	50	3.200	2046583
SV25W SW	28.1	25.7	60	30	1.2	Jet black	50	5.500	2046584
SV32W SW	35.2	32.8	70	35	1.2	Jet black	50	7.900	2046585
SV40W SW	43.8	40.8	80	40	1.5	Jet black	25	13.200	2046586
SV50W SW	54	51	100	50	1.5	Jet black	10	20.000	2046587
SV63W SW	67	64	100	50	1.5	Jet black	5	28.000	2046588

Accessory part: plug-in sleeve for the connections between electrical installation pipes. With burr-free inner wall.

Armoured steel pipe without thread, electrogalvanised

St G



4 | 4 | 5 | 7 | 1

Type	Dim. D mm	Dim. L mm	Dim. t mm		Pack m	Weight kg/100 m	Item no.
S16W G	16	3000	1		30	37.000	2046840
S20W G	20	3000	1		30	44.700	2046841
S25W G	25	3000	1.2		30	70.400	2046842
S32W G	32	3000	1.2		21	91.200	2046843
S40W G	40	3000	1.2		15	139.700	2046844
S50W G	50	3000	1.2		15	176.000	2046845
S63W G	63	3000	1.2		9	223.000	2046846

Electrical installation pipe without threaded ends according to EN 61386-1 for mechanical protection of cables. With burr-free inner wall.

Armoured steel pipe connection sleeve without thread, electrogalvanised

St G



Type	Dim. D mm	Dim. d mm	Dim. L mm	Dim. l mm	Dim. t mm		Pack Piece	Weight kg/100 pc.	Item no.
SV16W G	18.6	16.6	50	25	1		25	2.100	2046854
SV20W G	23.1	20.7	60	30	1.2		50	2.800	2046855
SV25W G	28.1	25.7	60	30	1.2		50	4.800	2046856
SV32W G	35.2	32.8	70	35	1.2		50	7.200	2046857
SV40W G	43.8	40.8	80	40	1.5		25	13.200	2046858
SV50W G	54	51	100	50	1.5		10	20.000	2046859
SV63W G	67	64	100	50	1.5		5	28.000	2046860

Accessory part: plug-in sleeve for the connections between electrical installation pipes. With burr-free inner wall.

St FT

Hot-dip galvanised steel pipe, without thread

Type	Dim.	Dim.	Dim.	Pack	Weight	Item no.
	D	L	t			
	mm	mm	mm	m	kg/100 m	
S16W FT	16	3000	1	30	37.000	2046593
S20W FT	20	3000	1	30	44.700	2046594
S32W FT	32	3000	1.2	21	91.200	2046596
S40W FT	40	3000	1.2	15	139.700	2046597



Electrical installation pipe without threaded ends according to EN 61386-1 for mechanical protection of cables. With burr-free inner wall. Corrosion protection class 4 (high).

4 | 4 | 5 | 7 | 1

St FT

Hot-dip galvanised steel sleeve, without thread

Type	Dim.	Dim.	Dim.	Dim.	Dim.	Pack	Weight	Item no.
	D	d	L	l	t			
	mm	mm	mm	mm	mm	Piece	kg/100 pc.	
SV16W FT	18.6	16.6	50	25	1	25	2.200	2046620
SV32W FT	35.2	32.8	70	35	1.2	50	7.500	2046623
SV40W FT	43.8	40.8	80	40	1.5	25	14.400	2046624

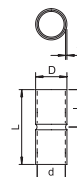

Accessory part: plug-in sleeve for the connections between electrical installation pipes. With burr-free inner wall.

PE

Pipe end cap, splittable, metric, black

Type	Size	Dim.	Dim.	Dim.	Dim.	Colour	Pack	Weight	Item no.
		D1	D2	L1	L2				
		mm	mm	mm	mm		Piece	kg/100 pc.	
129 TB M16 SW	M16	20	10	30	3	Black	50	0.400	2047936
129 TB M20 SW	M20	24	13.4	30	3	Black	50	0.440	2047944
129 TB M25 SW	M25	30	18.4	30	3	Black	50	0.500	2047952
129 TB M32 SW	M32	36	25.4	30	3	Black	50	0.656	2047971
129 TB M40 SW	M40	44	33.4	30	3	Black	30	0.790	2047979
129 TB M50 SW	M50	53	43	30	3	Black	30	0.935	2047987
129 TB M63 SW	M63	67	56	30	3	Black	20	1.140	2047995

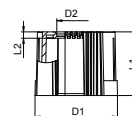

Separable pipe end cap to slot onto metric electrical installation pipes.

The separable pipe end cap can be used for repairs on existing installations according to regulations. It is not necessary to disconnect the cables, allowing quick mounting.

Clamp clips with profile rails

System description

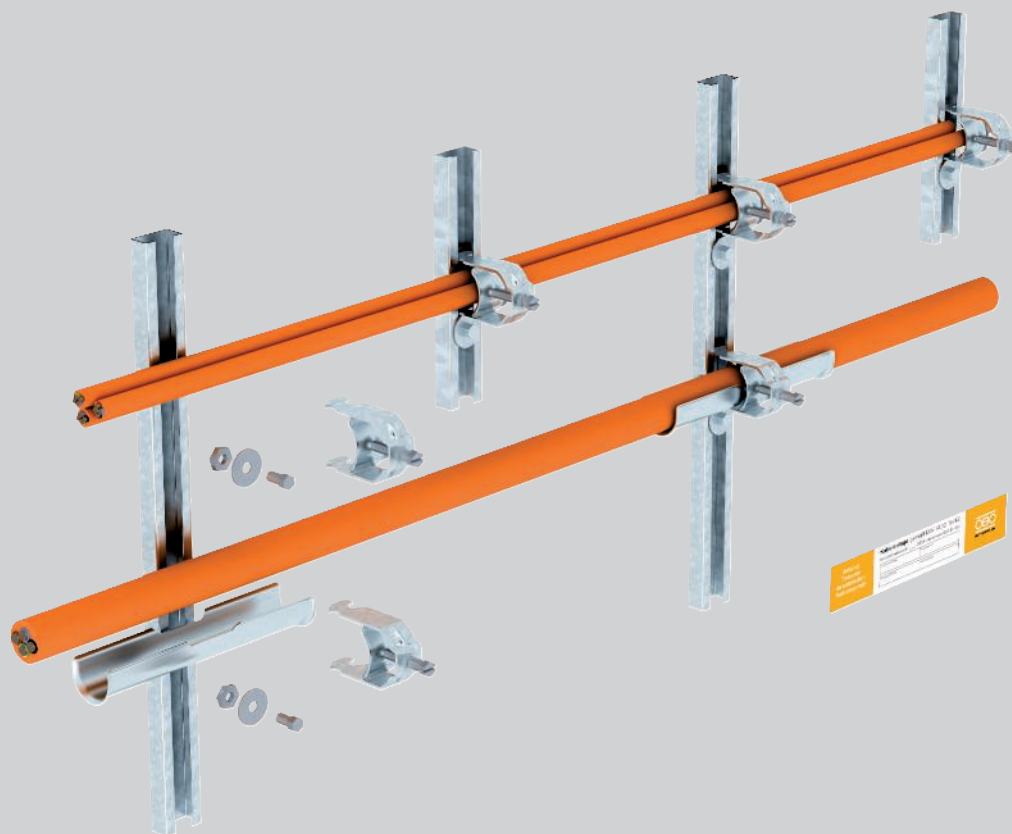

The routing types with clamp clips fulfil all the requirements of DIN 4102 Part 12 as a standard support structure for the maintenance of electrical functionality classes E30 and E90. Mounting as a cable-specific routing type is possible, depending on the specifications of the cable manufacturer. The clamp clips can be used for horizontal cable routing on walls and ceilings and vertical routing on walls. The clamp clips are made of sheet steel with a riveted metal pressure trough. Long troughs

made of galvanised sheet steel can be used to increase the support area for the cables. These are inserted loosely between the cables and the metal pressure troughs of the clamp clips. Bundling of up to three cables in a clamp clip is possible. The individual diameter of the bundled cables may not exceed 25 mm. If only individual cables are installed, then there is no limit to the cable diameter.

Clamp clips with profile rails

Installation principle



Horizontal mounting with clamp clips and long troughs on the wall and under the ceiling.



Horizontal cable mounting with clamp clips on the wall.



Horizontal cable mounting with clamp clips under the ceiling.

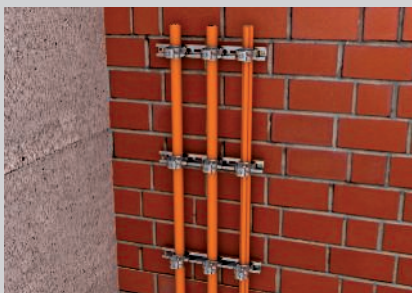

Vertical cable mounting with clamp clips on the wall.



Installation of the cables, either individually or as a bundle.

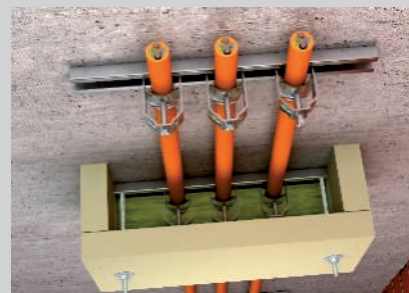

Effective support measure with ZSE90 strain relief.

Classification according to DIN 4102 Part 12

E30

E60

E90

System description

Routing type	Standard support structure Cable-specific support construction
Surveyor's report no.	GS 3.2/17-436-5 (Norm)
Maintenance of electrical function classes	E30 to E90
Testing standard	DIN 4102 Part 12

Approved data

Rail fastening distance, max.	0.3 m (without long trough) as standard support structure
Rail fastening distance, max.	0.6 m (with long trough) as standard support structure
Max. anchor spacing in rail	0.25 m
Max. individual cable diameter	62 mm with long trough, 100 mm without long trough
Max. cable bundle	A standard support structure, max. 3 power cables up to \varnothing 25 mm or a bundle of installation cables with a total weight of 3.0 kg/m
Cable-specific	Cable types and mounting parameters dependent on the cable manufacturer

Standard routing type: The data of the surveyor's report applies, together with a valid, general construction test certificate of a materials testing institute for the cable type to be used. Cable-specific routing type: A general construction test certificate of a materials testing institute for the cable type to be used is sufficient as proof.

With regard to the fastening distance and cable assignment, the details from the appropriate test certificate must be taken into account.

Anchor rail AML3518, slot width 16.5 mm, perforated

St FT

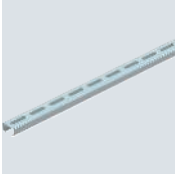

Type	Length mm	Dimension W x H mm	Material thickness mm	Dim. L mm	Pack m	Weight kg/100 m	Item no.

Central C profile rail for cable routing, in conjunction with clamp clips with a hammerhead foot. Can also be used as suspension construction for cable support systems.

Dimensions

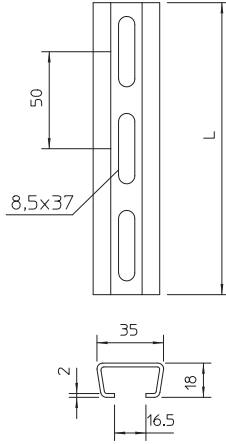

CML3518 profile rail, slot 17 mm, perforated

St FS



Type	Length mm	Dimension W x H mm	Material thickness mm	Dim. L mm	Pack m	Weight kg/100 m	Item no.

Light-duty profile rail, perforated, slot width 17 mm.

Dimensions

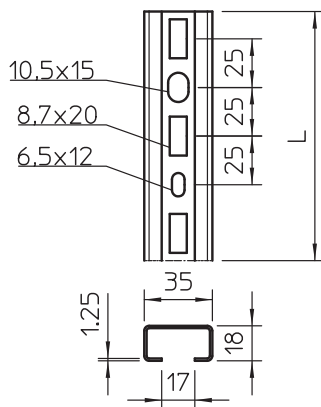

St FT

MS4022 mounting rail, heavy duty, slot 18 mm, perforated

Type	Dimension		Material thickness mm	Dim. L mm	Pack m	Weight kg/100 m	Item no.
	Length mm	W x H mm					
MS4022P2000FT	2000	40 x 22,5	2	2000	2	152.500	1121979



Heavy-duty C profile rail for individual installation of support constructions, e.g. for cable trays or as a panel for switchgear cabinets. Can also be used for cable routing, in conjunction with clamp clips with a U foot.

Dimensions

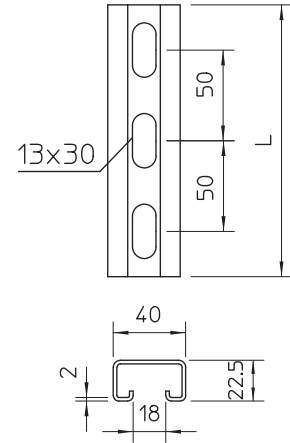

Screw-in spacer clips

System description



The routing types with single clips fulfil all the requirements of DIN 4102 Part 12 as a standard support structure for the maintenance of electrical functionality classes E 30, E 60 and E 90. In addition, mounting of the single clips as a cable-specific routing type is possible, depending on the specifications of the cable manufacturer. The screw-in spacer clips can be used for horizontal cable routing on walls and ceilings and vertical routing on walls. The closed screw-in spacer clips

are made of galvanized sheet steel. Mounting is carried out either by pushing through the slots of the clips or by screwing onto a fire protection anchor with threaded tip M6. Bundling of up to three cables together in a single clamp clip is possible for mounting as a standard support structure. The individual diameter of the bundled cables may not exceed 25 mm. There is no limit to the diameter of installed individual cables with screw-in spacer clips.

Screw-in spacer clips

Installation principle



Horizontal cable mounting on the wall.



Mounting under the ceiling.

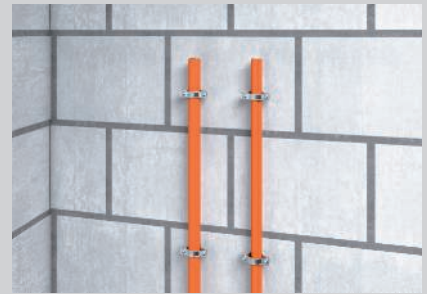

Vertical cable installation as individual and bundle routing on the wall.



Bundled cable routing under the ceiling.

Classification according to DIN 4102 Part 12

E30

E60

E90

System description

Routing type	Standard support structure Cable-specific support construction
Surveyor's report no.	GS 3.2/17-436-5 (Norm)
Maintenance of electrical function classes	E30 to E90
Testing standard	DIN 4102 Part 12

Approved data

Max. fastening spacing	0.3 m as standard support structure
Max. individual cable diameter	63 mm
Max. cable bundle	A standard support structure, max. 3 power cables up to \varnothing 25 mm or bundle of installation cables with a total weight of 3.0 kg/m
Cable-specific	Cable types and mounting parameters dependent on the cable manufacturer

Standard routing type: The data of the surveyor's report applies, together with a valid, general construction test certificate of a materials testing institute for the cable type to be used. Cable-specific routing type: A general construction test certificate of a materials testing institute for the cable type to be used is sufficient as proof.

With regard to the fastening distance and cable assignment, the details from the appropriate test certificate must be taken into account.



Spacer clip 732



Type	Clamping range D mm	Pack Piece	Weight kg/100 pc.	Item no.
ASG 732 25 A4	20-25	25	2.394	1362472

Spacer clip for the installation of pipes and cables on walls, ceilings and floors. With self-locking cover. Fastening via attachment piece with internal thread. Approved for the maintenance of electrical function according to DIN 4102 Part 12, maintenance of electrical function classes E 30 to E 90.

Dimensions

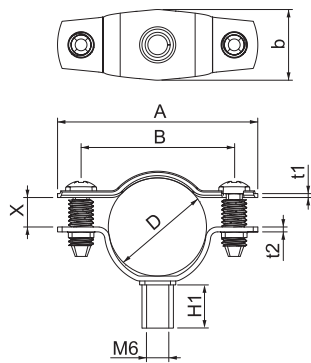

Type	Clamping range D mm	Dim. A mm	Dim. B mm	Dim. x mm	Dim. t1 mm	Dim. t2 mm	Dim. H1 mm
ASG 732 25 A4	20-25	51	39	7.5	18	1.25	1.25

Spacer clip 733



Type	Clamping range D mm	Pack Piece	Weight kg/100 pc.	Item no.
ASL 733 63 FT	53-63	20	6.477	1362738

Spacer clip for the installation of pipes and cables on walls, ceilings and floors. With self-locking cover. Fastening via slot. Approved for the maintenance of electrical function according to DIN 4102 Part 12, maintenance of electrical function classes E 30 to E 90.

Dimensions

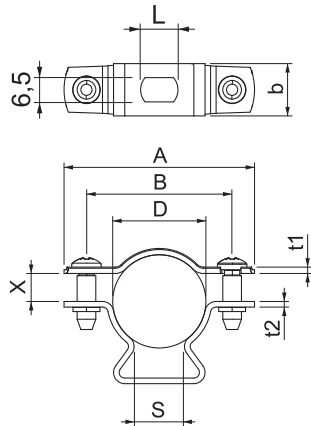

Type	Dim. A mm	Dim. B mm	Dim. x mm	Dim. t1 mm	Dim. t2 mm	Dim. L mm	Dim. b mm	Dim. s mm
ASL 733 63 FT	94	80	15	1.5	2	10	16	35.3

A4



Spacer clip 733

Type	Clamping range D mm	Pack Piece	Weight kg/100 pc.	Item no.
ASL 733 25 A4	20-25	25	2.466	1362918

Spacer clip for the installation of pipes and cables on walls, ceilings and floors. With self-locking cover. Fastening via slot.
Approved for the maintenance of electrical function according to DIN 4102 Part 12, maintenance of electrical function classes E 30 to E 90.

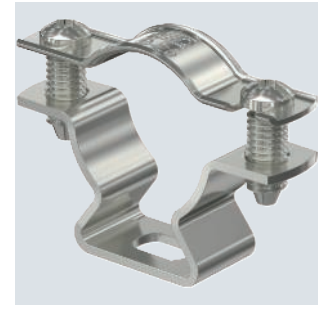

Type	Dim. A mm	Dim. B mm	Dim. x mm	Dim. t1 mm	Dim. t2 mm	Dim. L mm	Dim. b mm	Dim. s mm
ASL 733 25 A4	51	39	7.5	1.25	1.5	10	14	13.5

Dimensions

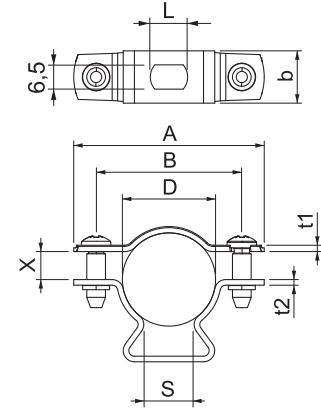

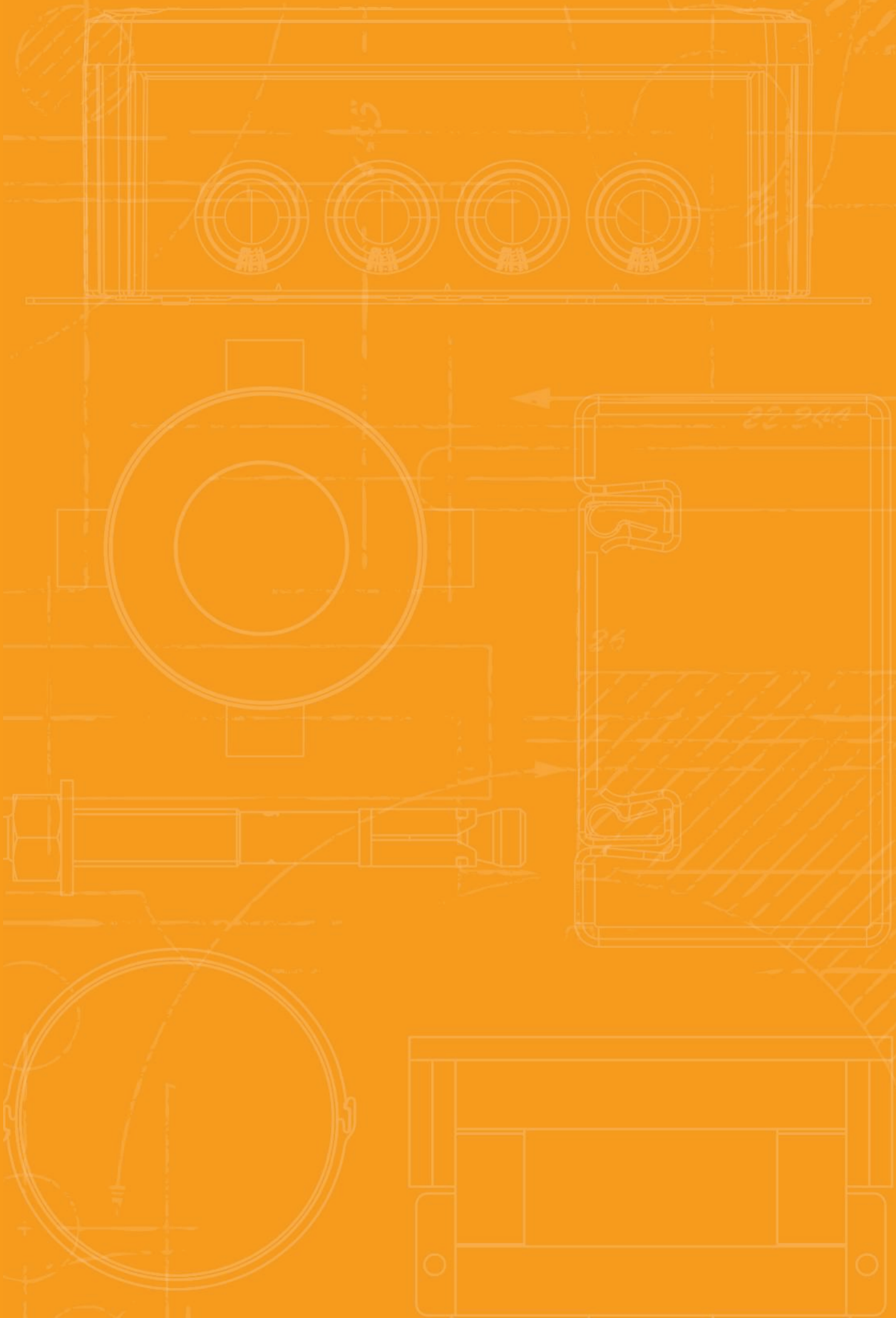

Escape route installations, false ceiling mounting



False ceiling cable trays and mesh cable trays

84



RKS-Magic® cable tray

System description

30

60

90

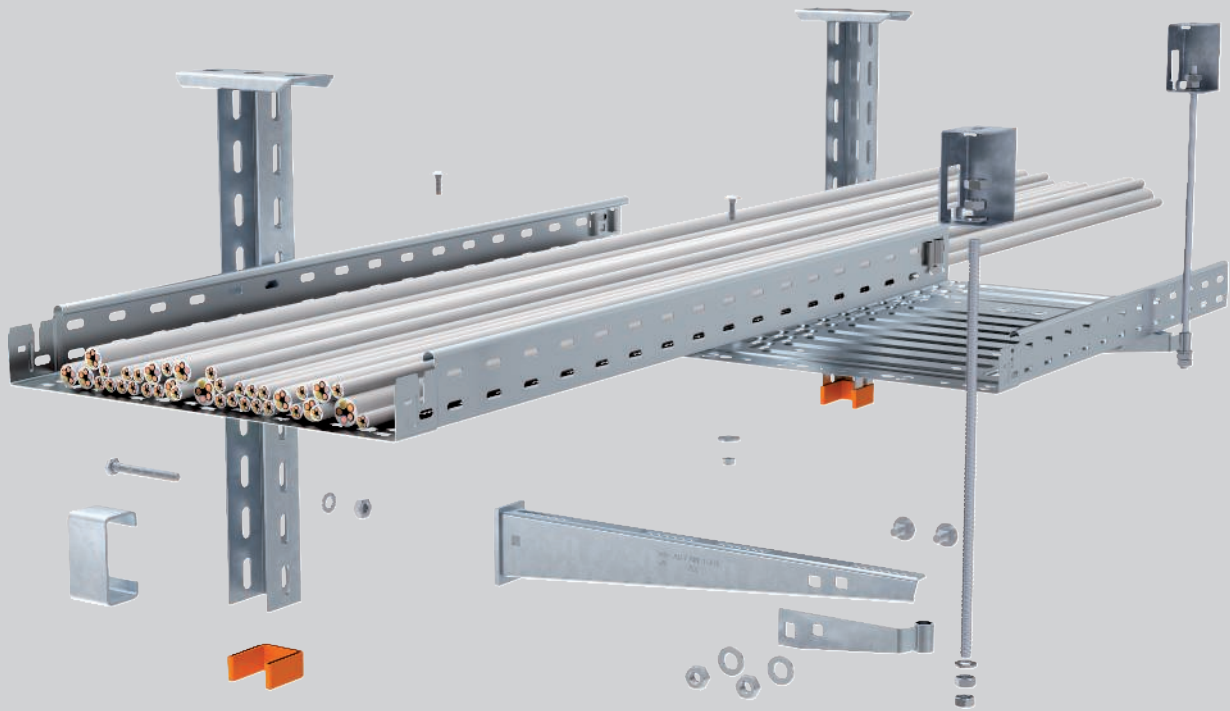

The tested RKS-Magic® cable tray system is suitable for installation in the false ceiling area of escape routes. In the event of fire, the system has a proven mechanical stability of 30, 60 and 90 minutes, depending on the system components used. The RKS-Magic® cable tray can be mounted under the ceiling or on the wall with brackets. The brackets are additionally secured on the ceiling with a threaded rod to prevent them from bending in a fire. The AW15 brackets in the widths 110 to

410 mm have the required perforations at the bracket tip to fasten the matching connection components. A further option for ceiling mounting is the support of the cable tray on profile rails, each mounted under the ceiling with two threaded rods. If the cable loads and tray widths listed in the proof of testing are maintained and the minimum spacings to the false ceiling is taken into account, then multi-layer variants can also be implemented.

Fireproof fastening above fire protection ceilings

Fire load	30/60/90 minutes
Proof of testing	OBO Bettermann
Document no. - mounting with mounting rails	BS-05/190-01-01
Document no. - mounting with suspended support/bracket	BS-05/190-01-02
Testing principles	In accordance with DIN 4102

RKS-Magic® cable tray

Installation principle



Single-layer ceiling suspension.



Two-layer ceiling suspension with bracket arrangement on one side.



Two-layer ceiling suspension with bracket arrangement on both sides.



Wall mounting, one and two-layer possible.



Mounting of the threaded rod lock using a connection component at the bracket tip.



Complete screwless joint connection.



Single-layer ceiling mounting above suspended fire protection ceiling.



Two-layer ceiling mounting above suspended fire protection ceiling.



Clamp fastening for high load capacities.

Tested mounting options



CAUTION: No maintenance of electrical functionality according to DIN 4102 Part 12!

RKS-Magic® cable tray

Maximum support distances for wall and ceiling mounting

Cable tray width [mm]	Fire load [min] Max. cable load [kg/m]		Maximum support distance [m]						
	30	60/90	1.50	1.50	1.50	1.50	1.50	1.50	1.50
100	15	10	1.50	1.50	1.50	1.50	1.50	1.50	1.50
200	30	20							
300	45	30							
400	60	40							

Required minimum distance „a“ for the fire load at different support distances

Maximum support distance [m]	0.50			0.75			1.00			1.25			1.50		
	30	60	90	30	60	90	30	60	90	30	60	90	30	60	90
Cable tray width [mm]	Minimum distance „a“ [mm]														
100	30	30	30	30	35	40	30	70	90	45	130	140	60	145	150
200	30	35	40	50	55	60	70	95	100	115	140	145	160	150	160
300	40	45	50	70	75	85	105	110	120	130	145	150	160	155	160
400	60	60	65	80	80	95	105	120	130	130*	155	160*	160*	160	165*

*Observe the maximum support distances according to the table: „Maximum support distances for wall and ceiling mounting“.
The minimum distance „a“ refers to the distance from the underside of the cable tray to the upper side of the fire protection ceiling.

Deformation of the RKS-Magic® cable tray in mm for 30-minute fire load

- 1 RKSM 610
- 2 RKSM 620
- 3 RKSM 630
- 4 RKSM 640

A = Minimum distance "a" in mm to the fire protection ceiling
B = Support distance in m

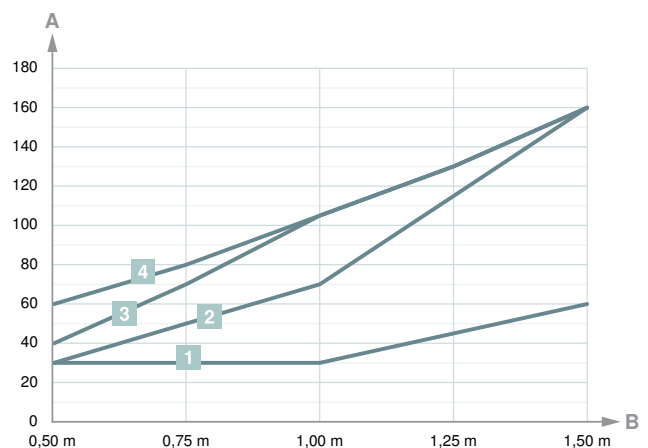
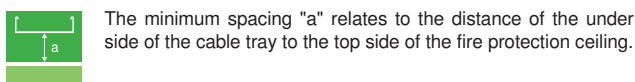



30

60

90







Component assignment

Components to be used for single and double layer mounting at the fire load of 30/60/90 minutes

Components	Suspended support type when mounting		Bracket Type	Mounting rail type				
				Maximum support distance [m]				
Cable tray width [mm]		 		0.50	0.75	1.00	1.25	1.50
100	US 3 K...FT	US 3 K...FT	AW 15 11 FT	MS4121P				
200			AW 15 21 FT					
300		US 5 K...FT	AW 15 31 FT	MS4121P	MSL4141P			MS4141P
400			AW 15 41 FT	MSL4141P			MS4141P*	

*Observe the maximum support distances according to the table: „Maximum support distances for wall and ceiling mounting“.

Assignment of threaded rods at the fire loads of 30/60/90 minutes

Cable tray width [mm]	Maximum support distance [m]					Maximum support distance [m]				
										
	0.50	0.75	1.00	1.25	1.50	0.50	0.75	1.00	1.25	1.50
100	M8					M8		M10		
200										
300	M8		M10			M10		M12		
400										

*Observe the maximum support distances according to the table: „Maximum support distances for wall and ceiling mounting“.

Deformation of the RKS-Magic® cable tray in mm for 60-minute fire load

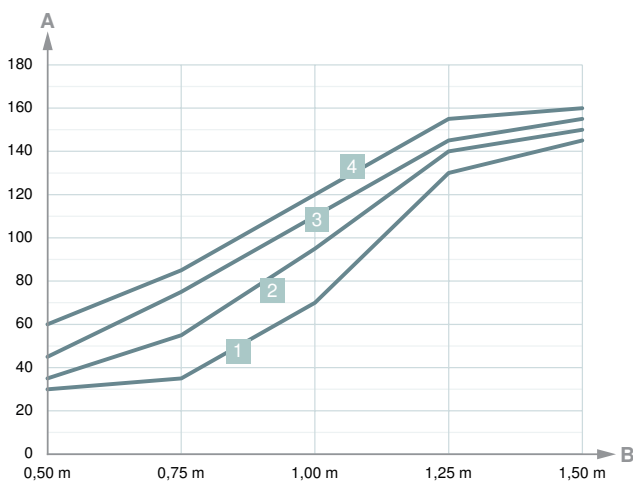

Deformation of the RKS-Magic® cable tray in mm for 90-minute fire load

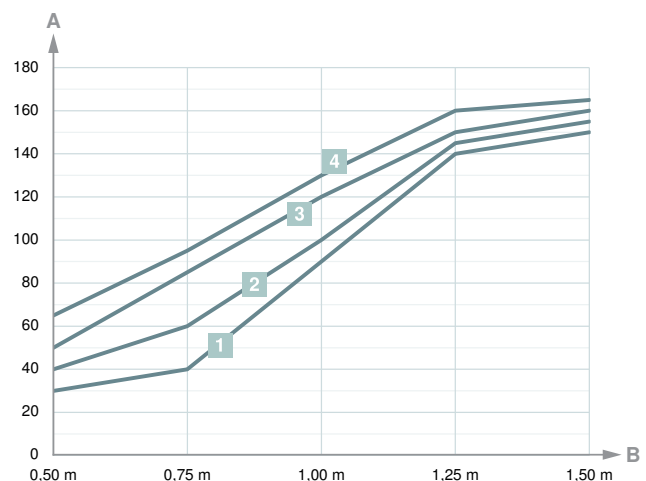

Cable tray SKS-Magic®

System description

30

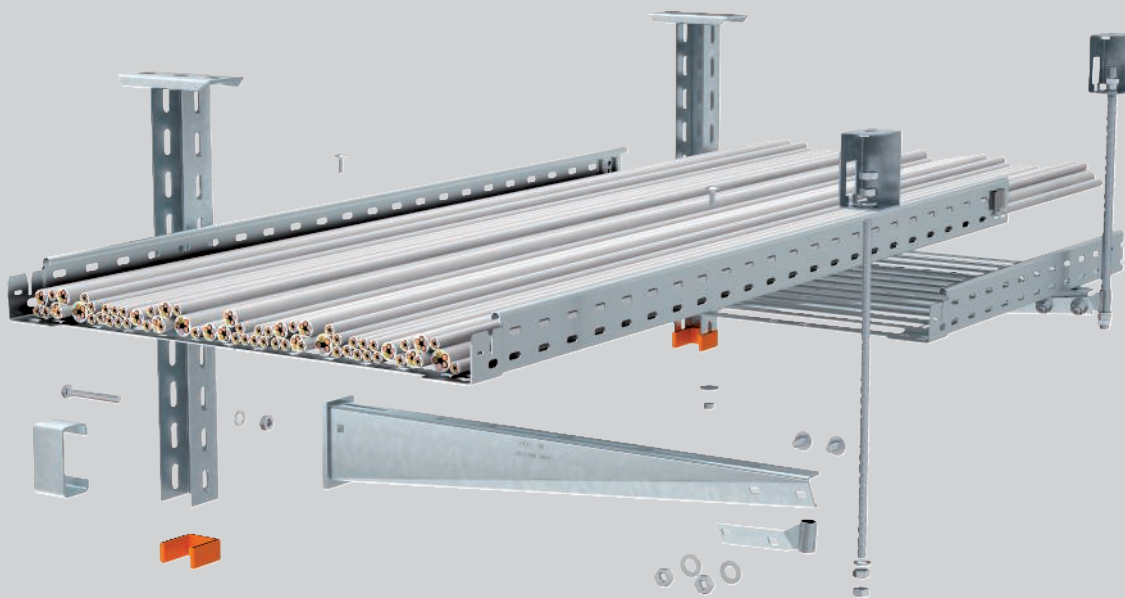

The tested SKS-Magic® cable tray system is suitable for installation in the false ceiling area of escape and rescue routes. In the event of fire, the system has a proven mechanical stability of 30 minutes. The SKS-Magic® cable tray can be mounted under the ceiling or on the wall using brackets. The brackets are additionally secured on the ceiling with a threaded rod to prevent them from bending in a fire. The AW15 brackets in the widths 110 to 410 mm and the AW30 brackets in the widths 510 and 610 mm have the required perforations at the bracket tip to fasten the

matching connection components. If the cable loads and tray widths listed in the proof of testing are maintained and the minimum spacings to the false ceiling is taken into account, then multi-layer variants can also be implemented. A further option for ceiling mounting is the support of the cable trays on profile rails, each mounted under the ceiling with two threaded rods. A two-layer arrangement of the cable trays is possible, providing that the approved tensile stress in the threaded rods is also maintained in the event of fire.

Fireproof fastening above fire protection ceilings

Fire load	30 minutes
Proof of testing	OBO Bettermann
Document no. - mounting with mounting rails	BS-05/190-02-01
Document no. - mounting with suspended support/bracket	BS-05/190-02-02
Testing principles	In accordance with DIN 4102

Proofs of testing are also available for the SKS cable trays and can be requested.

Cable tray SKS-Magic®

Installation principle



Single-layer ceiling suspension.



Two-layer ceiling suspension with bracket arrangement on one side.



Two-layer ceiling suspension with bracket arrangement on both sides.



Wall mounting, one and two-layer possible.



Mounting of the threaded rod lock using a connection component at the bracket tip.



Screwless joint connection, only the base lugs need to be bent.



Single-layer ceiling mounting above suspended fire protection ceiling.



Two-layer ceiling mounting above suspended fire protection ceiling.



Clamp fastening for high load capacities.

Tested mounting options



CAUTION: No maintenance of electrical functionality according to DIN 4102 Part 12!

Cable tray SKS-Magic®

Maximum support distances for wall and ceiling mounting

Cable tray width [mm]	Fire load [min] Max. cable load [kg/m]	Maximum support distance [m]					
		1.50	1.50	1.50	1.50	1.50	1.50
100	15	1.50	1.50	1.50	1.50	1.50	1.50
200	30						
300	45						
400	60						
500	75						
600	90						

Required minimum distance „a“ for the fire load at different support distances

Maximum support distance [m]	0.50	0.75	1.00	1.25	1.50
Fire load [min]	30				
Cable tray width [mm]	Minimum distance „a“ [mm]				
100	20	20	20	20	20
200	20	30	30	30	30
300	30	40	55	70	85
400	40	60	85	105*	130*
500	50	70	95*	120*	145*
600	60	80	105*	140*	175*

*Observe the maximum support distances according to the table: „Maximum support distances for wall and ceiling mounting“.
The minimum distance „a“ refers to the distance from the underside of the cable tray to the upper side of the fire protection ceiling.

Deformation of the SKS-Magic® cable tray in mm for 30-minute fire load

1	SKSM 610
2	SKSM 620
3	SKSM 630
4	SKSM 640
5	SKSM 650
6	SKSM 660

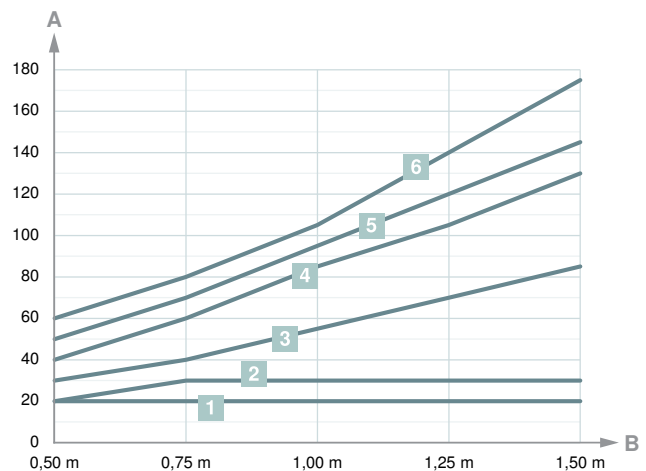

A = Minimum distance "a" in mm to the fire protection ceiling
B = Support distance in m

 The minimum spacing "a" relates to the distance of the under side of the cable tray to the top side of the fire protection ceiling.













Component assignment

Components to be used for single and double layer mounting at a fire load of 30 minutes

Components	Suspended support type when mounting		Bracket Type	Mounting rail type					
				Maximum support distance [m]					
Cable tray width [mm]		 		0.50	0.75	1.00	1.25	1.50	
100	US 3 K...FT	US 3 K...FT	AW 15 11 FT	MS4121P					
200			AW 15 21 FT						
300		US 5 K...FT		AW 15 31 FT	MS4121P	MSL4141P		MS4141P	
400	AW 15 41 FT			MSL4141P		MS4141P*			
500	US 5 K...FT			AW 30 51 FT	MS4141P*				
600				AW 30 61 FT					

*Observe the maximum support distances according to the table: „Maximum support distances for wall and ceiling mounting“.

Assignment of the threaded rods at the fire load of 30 minutes

Cable tray width [mm]	Maximum support distance [m]					Maximum support distance [m]				
										
Cable tray width [mm]	0.50	0.75	1.00	1.25	1.50	0.50	0.75	1.00	1.25	1.50
100	M8					M8		M10		
200										
300	M8		M10			M10		M12		
400										
500	M10			M12		M12		M12*	-	
600								-		

*Observe the maximum support distances according to the table: „Maximum support distances for wall and ceiling mounting“.

GR-Magic® mesh cable tray

System description

30

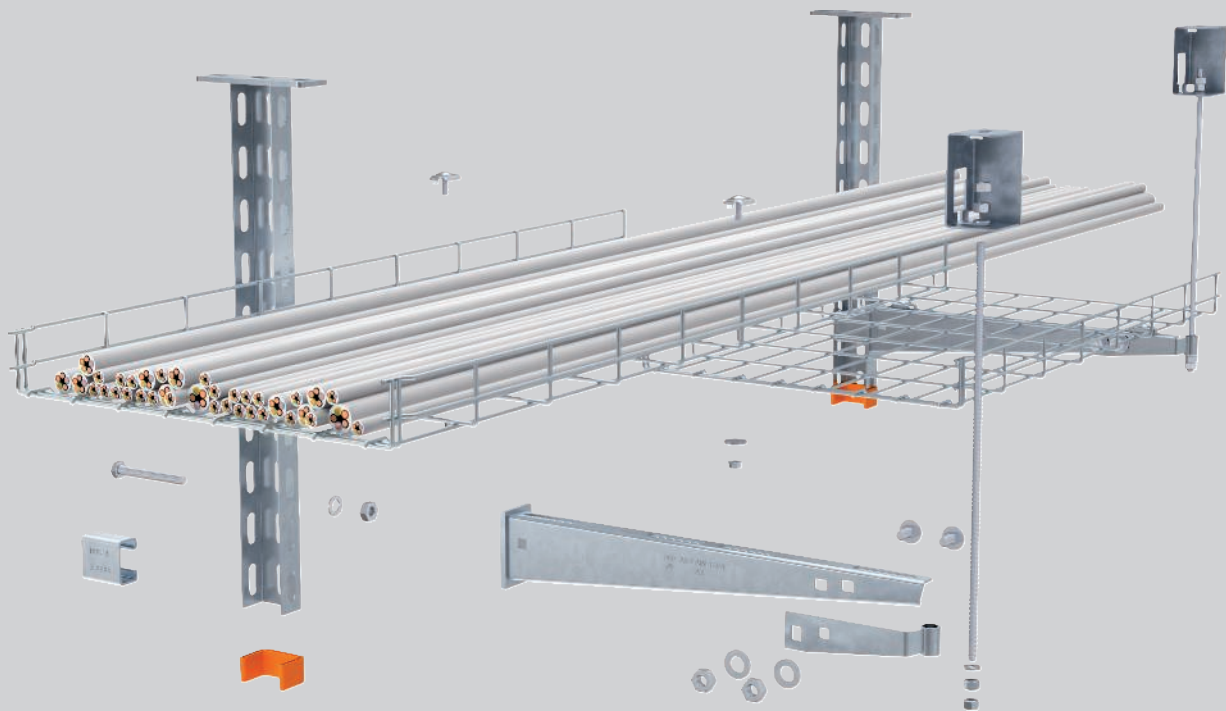

The tested GR-Magic® mesh cable tray system is suitable for installation in the false ceiling area of escape and rescue routes. In the event of fire, the system has a proven mechanical stability of 30 minutes. The GR-Magic® mesh cable tray can be mounted under the ceiling or on the wall using brackets. The brackets are additionally secured on the ceiling with a threaded rod to prevent them from bending in a fire. The AW15 brackets in the widths 110 to 410 mm have the required perforations at the bracket tip to fasten the matching connection components. If the cable

loads and tray widths listed in the proof of testing are maintained and the minimum spacings to the false ceiling is taken into account, then multi-layer variants can also be implemented. A further option for ceiling mounting is the support of the mesh cable tray on profile rails, each mounted under the ceiling with two threaded rods. With this mounting variant, sufficient distances to the false ceiling must be maintained. A two-layer arrangement of the mesh cable trays is possible, providing that the approved tensile stress in the threaded rods is also maintained in the event of fire.

Fireproof fastening above fire protection ceilings

Fire load	30 minutes
Proof of testing	OBO Bettermann
Document no. - mounting with mounting rails	BS-05/190-03-01
Document no. - mounting with suspended support/bracket	BS-05/190-03-02
Testing principles	In accordance with DIN 4102

GR-Magic® mesh cable tray

Installation principle



Single-layer ceiling suspension with suspended support and bracket.



Two-layer ceiling suspension with bracket arrangement on one side.



Two-layer ceiling suspension with bracket arrangement on both sides.



Wall mounting, one and two-layer possible.

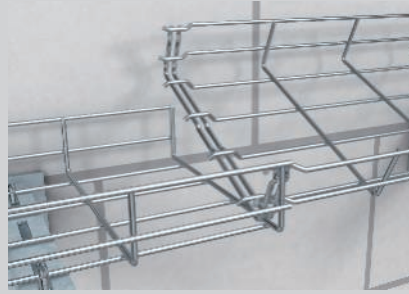

Screwless joint connection through interconnection of two delivery lengths of the mesh cable tray.



Mounting of the threaded rod lock using a connection component at the bracket tip.



Single-layer ceiling mounting above suspended fire protection ceiling.



Two-layer ceiling mounting above suspended fire protection ceiling.



Clamp fastening for high load capacities.

Tested mounting options



CAUTION: No maintenance of electrical functionality according to DIN 4102 Part 12!

GR-Magic® mesh cable tray

Maximum support distances for wall and ceiling mounting

Mesh cable tray width [mm]	Fire load [min] Max. cable load [kg/m]						
	30	Maximum support distance [m]					
100	10	1.50					
200	20						
300	30						
400	40						

Required minimum distance „a“ for the fire load at different support distances

Maximum support distance [m]	0.50	0.75	1.00	1.25	1.50
Fire load [min]	30				
Mesh cable tray width [mm]	Minimum distance „a“ [mm]				
100	40	60	80	105	150
200	45	65	85	110	155
300	60	80	100	130	160
400	65	85	105	135	165

The minimum distance „a“ refers to the distance of the underside of the cable tray to the upper side of the fire protection ceiling.

Deformation of the GR-Magic® mesh cable tray in mm for 30-minute fire load

- 1 GRM 55 100
- 2 GRM 55 200
- 3 GRM 55 300
- 4 GRM 55 400

A = Minimum distance "a" in mm to the fire protection ceiling
B = Support distance in m

 The minimum spacing "a" relates to the distance of the underside of the mesh cable tray to the top side of the fire protection ceiling.

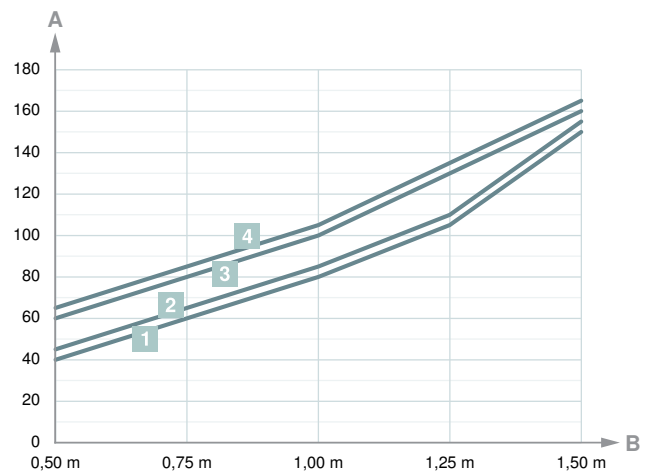

Cable tray RKS-Magic® 60

St FS

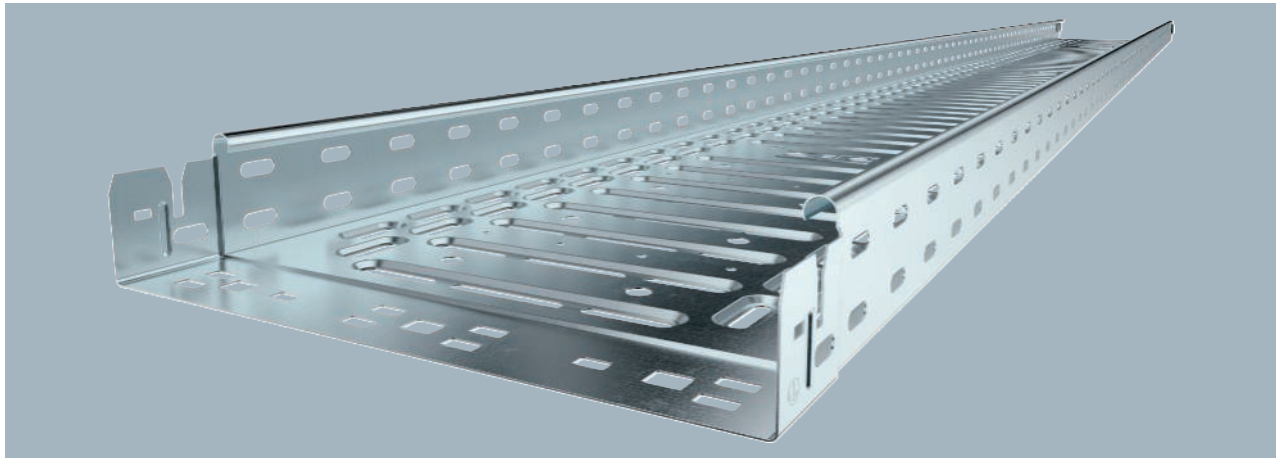

Type	Width mm	Metal thick- ness mm	BS	Pack m	Weight kg/100 m	Item no.
RKSM 610 FS	100	0.75		3	134.334	6047611
RKSM 620 FS	200	0.75		3	181.508	6047638
RKSM 630 FS	300	0.75		3	233.803	6047654
RKSM 640 FS	400	0.90		3	338.459	6047689

Cable tray with integrated quick fastening system. The usable length of the cable tray is 3,000 mm. The cable tray has continuous side perforations of 7 x 20 mm for the installation of additional connection and mounting components. The perforation for direct threaded rod suspension has a diameter of 11 mm.

Type	Length mm	Width mm	Usable cross- section cm ²	Dim- en- sion x y mm
RKSM 610 FS	3050	100	58	— 50
RKSM 620 FS	3050	200	118	100 150
RKSM 630 FS	3050	300	178	200 250
RKSM 640 FS	3050	400	238	300 350

Dimensions

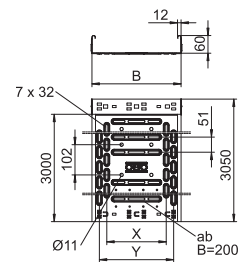

90° Magic bend 60

St FS

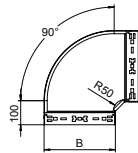
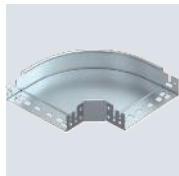

Type	Width mm	Dim. B mm	Pack Piece	Weight kg/100 pc.	Item no.
RBM 90 610 FS	100	100	1	65.700	6041130

90° bend with quick connector system. For all cable tray types of 60 mm side height.

Add-on tee 60

St FS

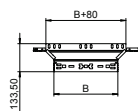
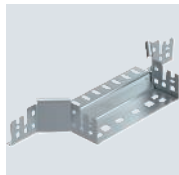

Type	Width mm	Dim. B mm	Pack Piece	Weight kg/100 pc.	Item no.
RAAM 630 FS	300	300	1	60.940	6041236

Magic add-on tee with quick connector system. For all cable tray types of 60 mm side height.

St FS

Magic straight connector set 60

Type	Width mm	Side height mm	Dim. B mm	Pack Piece	Weight kg/100 pc.	Item no.

Cable tray connector with quick fastening for the screwless connection of perforated cable trays with a side height of 60 mm.

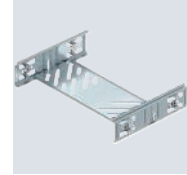
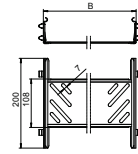

False ceiling, mesh cable tray

St G

GR-Magic® 55 mesh cable tray

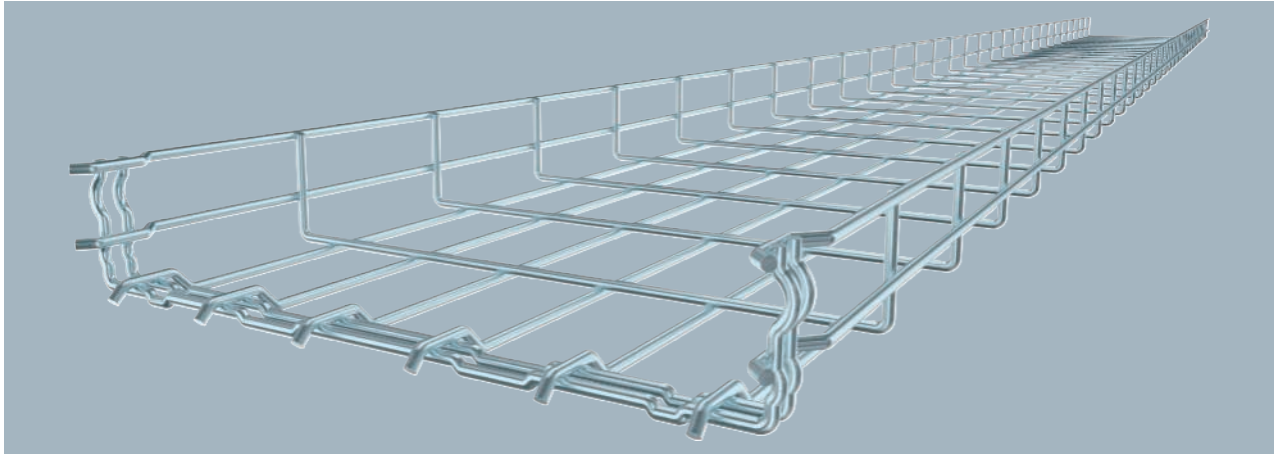

Mesh cable tray with shaped connector of side height 55 mm.

Type	Width mm	Wire Ø mm	Dim. B mm	BS	Pack m	Weight kg/100 m	Item no.
GRM 55 200 G	200	3.9	200		3	100.667	6001446
GRM 55 300 G	300	4.8	300		3	192.333	6001448
GRM 55 400 G	400	4.8	400		3	234.667	6001450

Dimensions

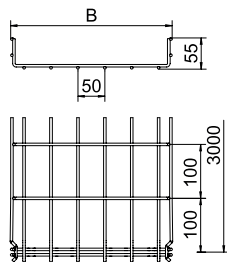

PVC

Protective caps

Type	Colour	Pack Piece	Weight kg/100 pc.	Item no.
GR KS 4.8 OR	Pure orange	500	0.030	6003754

Protective cap to cover cut wire ends of mesh cable trays.

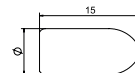

GKS 34 hold-down clamp

St G

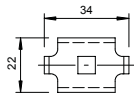

Type

GKS 34 G

Pack Piece	Weight kg/100 pc.	Item no.
20	2.188	6016855

Clamp for fixing mesh cable trays to wall or support brackets.

Joint connector GSV 34

St G

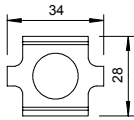

Type

GSV 34 G

Pack Piece	Weight kg/100 pc.	Item no.
20	3.155	6016596

Screwed version of joint connector for mesh cable trays.

St FT

US 3 support

Type	Length mm	Material thickness mm	Tensile load		Pack Piece	Weight kg/100 pc.	Item no.
			kN	BS			
US 3 K 20 FT	200	2	5		1	50.500	6342351
US 3 K 30 FT	300	2	5		1	64.400	6342353
US 3 K 40 FT	400	2	5		1	78.300	6342355
US 3 K 50 FT	500	2	5		1	92.300	6342357
US 3 K 60 FT	600	2	5		1	106.200	6342359
US 3 K 70 FT	700	2	5		1	120.200	6342362
US 3 K 80 FT	800	2	5		1	134.100	6342364
US 3 K 90 FT	900	2	5		1	147.800	6342366
US 3 K 100 FT	1000	2	5		1	162.000	6342368
US 3 K 110 FT	1100	2	5		1	175.900	6342370
US 3 K 120 FT	1200	2	5		1	189.900	6342372

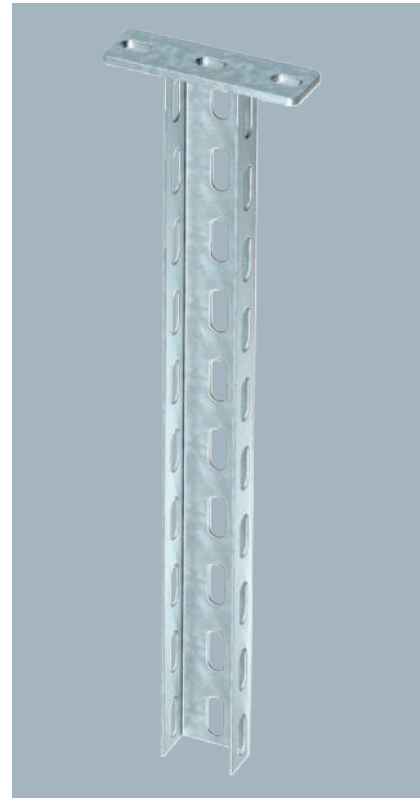

For fastening to horizontal concrete ceilings and steel girders. For bracket widths of 400 mm or more, or if the bracket is mounted at the end of a suspended support, we recommend the use of the spacer, type DSK 25.

Suspended support (U profile) of dimensions 50 x 30 mm with welded head plate.

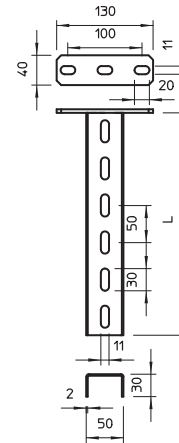

PE

Type	Colour	Pack Piece	Weight kg/100 pc.	Item no.
US 3 KS OR	Pastel orange	20	1.068	6338458

Protective cap to cover the ends of US 3 supports.

Protective cap

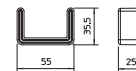

US 5 support

St FT

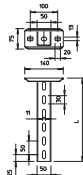

Type	Length mm	Material thickness mm	Dim. L mm	BS	Pack Piece	Weight kg/100 pc.	Item no.
US 5 K 40 FT	400	2.5	400		1	136.000	6341543
US 5 K 50 FT	500	2.5	500		1	161.000	6341551
US 5 K 80 FT	800	2.5	800		1	236.000	6341594
US 5 K 90 FT	900	2.5	900		1	261.000	6341608
US 5 K 100 FT	1000	2.5	1000		1	286.000	6341616
US 5 K 120 FT	1200	2.5	1200		1	337.000	6341632

U support of dimensions 50 x 50 mm with welded head plate.

Protective cap

PE

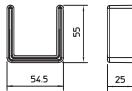

Type	Colour	Pack Piece	Weight kg/100 pc.	Item no.
US 5 KS OR	Pastel orange	20	1.300	6338462

Protective cap to cover the ends of US 5 supports.

Wall and support bracket AW 15

St FT

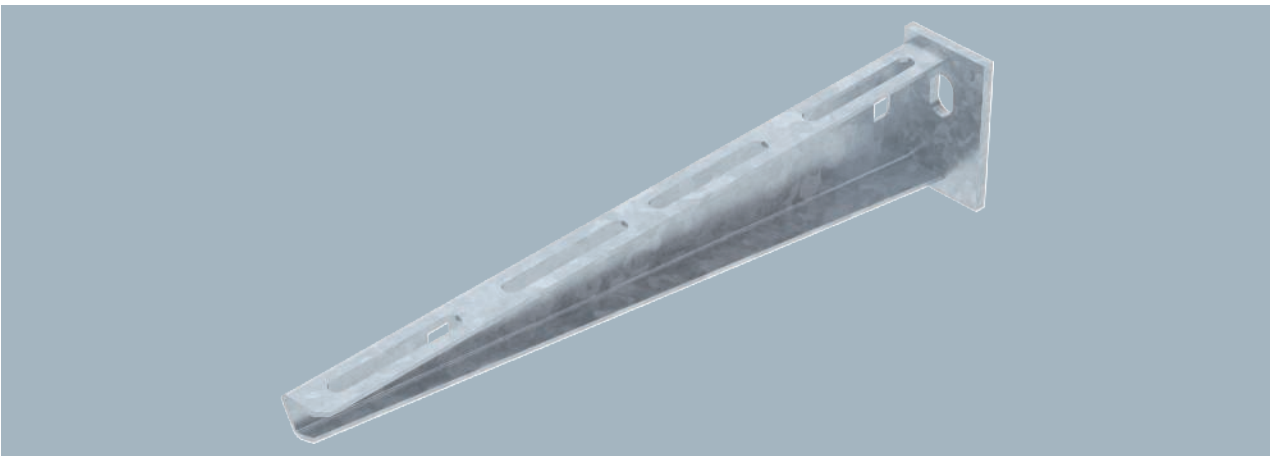

Type	Width mm	F in kN	Pack Piece	Weight kg/100 pc.	Item no.
AW 15 21 FT	210	1.5	1	24.000	6420680
AW 15 31 FT	310	1.5	1	38.400	6420710
AW 15 41 FT	410	1.5	1	54.000	6420745

Fastening of the bracket to the U support of width 400 mm or greater using a hexagonal bolt through both sides of the support. Please insert suitable spacers.
Light-duty wall and support bracket with welded head plate.

Type	Dim. B mm	Dim. A mm	Dim. H mm
AW 15 21 FT	210	40	60
AW 15 31 FT	310	40	65
AW 15 41 FT	410	40	70

Dimensions

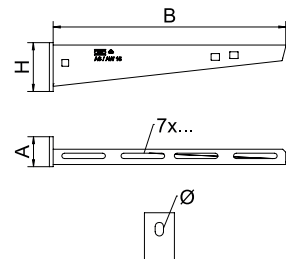

St FT

Wall and support bracket AW 30



Fastening of the bracket to the U support of width 400 mm or greater using a hexagonal bolt through both sides of the support. Please insert suitable spacers.

Medium-duty wall and support bracket with welded head plate.

Type	Width mm	F in kN		Pack Piece	Weight kg/100 pc.	Item no.
		mm	kN			
AW 30 61 FT	610	3		1	157.000	6419828

Dimensions

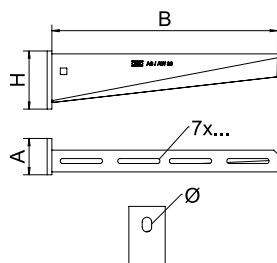

Type	Dim.	Dim.	Dim.	Hole Ø
	B	A	H	
AW 30 61 FT	610	50	100	13

St F

Hexagonal bolt M10

Type	Dimen- sion mm	Dim. L mm	Dim. d mm	SW mm	Resist- ance grade	Pack Piece	Weight kg/100 pc.	Item no.

Hexagonal bolt for universal fastening of construction components. With hexagonal nut and 2 washers.

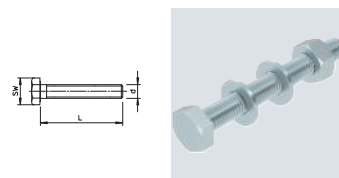

St FT

DSK 25 spacer

Type	Pack Piece	Weight kg/100 pc.	Item no.

Spacer for use in US 3 supports.

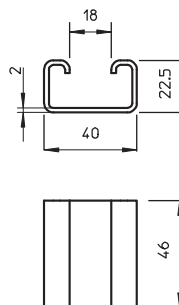

Spacer DSK 45

St FT

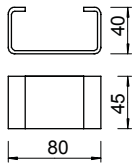

Type	Pack Piece	Weight kg/100 pc.	Item no.
DSK 45 FT	20	18.000	6416500

Spacer for use in US 5 support and in the head plate, type KU 7 VQP.

MS4121 mounting rail, slot 22 mm, perforated

St FT

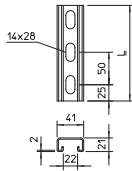

Type	Length mm	Dimension W x H mm	Material thickness mm	Dim. L mm		Pack Piece	Weight kg/100 pc.	Item no.
				L	BS			
MS4121P0200FT	200	41x21	2	200	🔥	1	35.100	1122933
MS4121P0300FT	300	41x21	2	300	🔥	1	53.000	1122934
MS4121P0500FT	500	41x21	2	500	🔥	1	87.000	1122936

Heavy-duty C profile rail for individual installation of support constructions, e.g. for cable trays or as a panel for switchgear cabinets. Can also be used for cable routing, in conjunction with clamp clips with a U foot.

MS4141 mounting rail, slot 22 mm, perforated

St FT

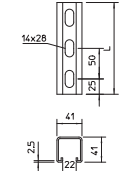

Type	Length mm	Dimension W x H mm	Material thickness mm	Dim. L mm		Pack m	Weight kg/100 m	Item no.
				L	BS			
MS4141P3000FT	3000	41x41	2.5	3000	🔥	3	261.400	1122622

Heavy-duty C profile rail for individual installation of support constructions, e.g. for cable trays or as a panel for switchgear cabinets. Can also be used for cable routing, in conjunction with clamp clips with a U foot.

Separating retainer 45

St FS

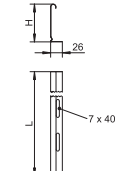

Type	Dim. H mm	Metal thickness mm	Dim. L mm	Pack m	Weight kg/100 m	Item no.

Separating retainer for separation of cables of different voltages or functions.

Hold-down clamp for separating retainer fastening in RKSM

VA 2B

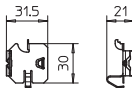
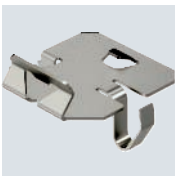

Type	Pack Piece	Weight kg/100 pc.	Item no.
KS KR A2	30	0.537	6062280

Hold-down clamp for screwless fastening of separating retainers in the cable tray types RKSM, MKS and SKS.

VA 2B

Hold-down clamp for separating retainer fastening in GRM

Type	Pack Piece	Weight kg/100 pc.	Item no.
KS GR A2	30	0.830	6062282

Hold-down clamp for fastening separating retainer in mesh cable trays.

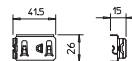

St G

Threaded rod

Type	Thread	Dim. d mm	Dim. L mm	Pack Piece	Weight kg/100 pc.	Item no.
TR M8 1M G	M8	8	1000	10	30.000	3141128
TR M10 1M G	M10	10	1000	10	49.000	3141209

Threaded rod to DIN 976.

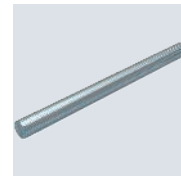

St G

Washer

Type	Thread	Dim. d mm	Dim. D mm	Dim. h mm	Pack Piece	Weight kg/100 pc.	Item no.
WS M10 D20 G	M10	10.5	20	2	100	0.408	3402096

Washer according to DIN 125, shape A, for universal use.

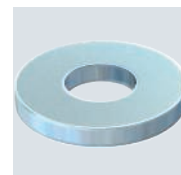
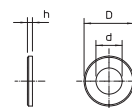

St G

Connection sleeve

Type	Thread	Dim. L mm	SW mm	Pack Piece	Weight kg/100 pc.	Item no.
CSTR M8 G	M8	24	13	50	1.880	6410081
CSTR M10 G	M10	30	17	50	4.150	6410103
CSTR M12 G	M12	40	19	25	7.000	6410111

Connection sleeve with continuous internal thread.





Anchoring



Metal spreading anchors

106

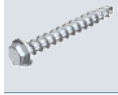

Bolt ties

110



Mounting material for insulated ceilings

114



Metal spreading anchor

System description

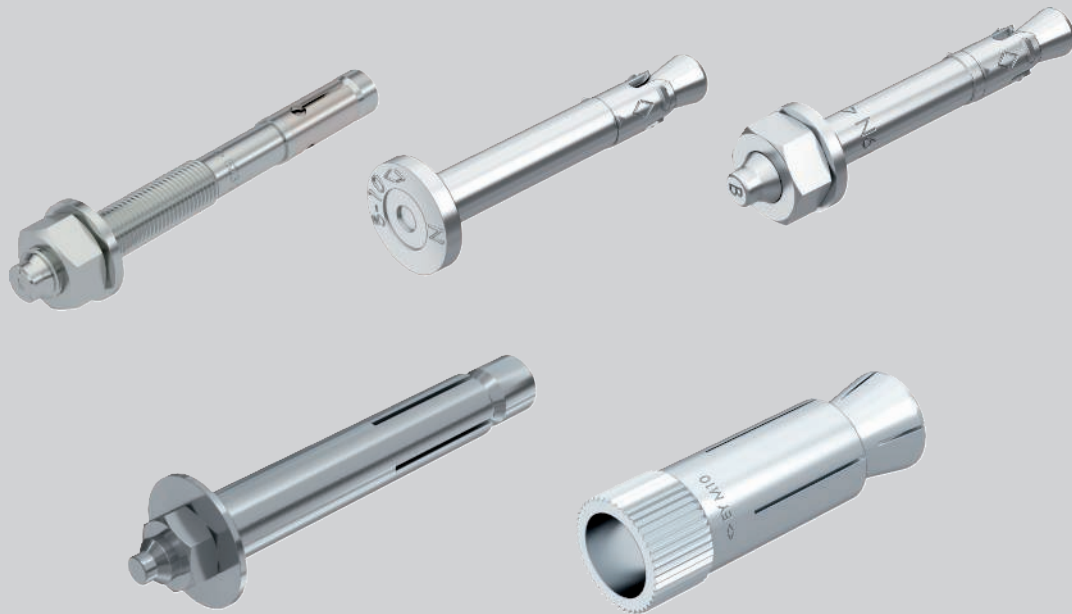

OBO Bettermann's metal spreading anchors for mounting in concrete components were tested for fire protection. Appropriate proofs are available for the tests carried out. Depending on the fire resistance length (up to 120 minutes), a maximum load capacity was determined when anchored in concrete. This load data is contained in the appropriate European technical approvals and

appropriate test documentation. Although the load capacity of the anchors during a fire is below the load capacity when cold, this load capacity is completely sufficient for fireproof fastening of the different routing types. Special metal spreading anchors are offered for false ceilings with a low concrete strength.



Metal spreading anchor

Installation principle



Nail tie, type N 6, with thread end.



Nail tie, type N-K 6, with flat head.



Bolt tie, type BZ.



Bolt tie, type BZ-IG.



Hollow core anchor, Easy type.

Classification according to proof of application

R30

R60

R90

R120

System description

Anchoring type	Anchor with spreading metal cone
Fire resistance classes	To R120 according to European Technical Approval ETA and general building inspectorate approval
Substrate	Concrete

The data of the approval documents and any fire testing reports apply



BZ3 bolt tie

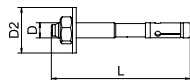

Type	Thread	Dim.		Pack Piece	Weight kg/100 pc.	Item no.
		L mm	D2 washer, external mm			
BZ3 8x75/0-20	M8	75	24*	50	3.000	3498683
BZ3 10x110/0-50	M10	110	30*	50	7.100	3498693

Bolt tie BZ3 for the anchoring of medium-duty to heavy-duty loads, both in cracked and non-cracked concrete. Suitable for heavy loads with small edge and axial distances. For knocking in.

European Technical Approval ETA-19/0619, including characteristic values under fire exposure to fire resistance R 120.

Proof of suitability in the event of seismic impacts, categories C1 and C2.

Shock approval by the Federal Office for Civil Protection in Bern, Switzerland.

* With large washer to DIN EN ISO 7093-1 (DIN 9021)





Bolt tie

System description



OBO Bettermann's fire protection bolt ties were fire-tested according to ETAG 001 Part 3. The maximum load capacity, depending on fire resistance periods of up to 120 minutes, was determined for different types of solid masonry. These values are documented in the appropriate test certificates. Taking the occurring loads for the maintenance of electrical function application and for false ceiling mounting into account, the

determined load capacities for the different masonry types are absolutely sufficient. The fire protection bolt ties are screwed directly into the drill hole. There is no need for an additional anchor. No spreading forces develop and mounting near masonry edges is not required. The bolt tie is equally suitable for cracked concrete in ceilings.



Bolt tie

Installation principle



Version with truss head and T drive.



Version with large truss head and T drive.



Version with hexagonal head.



Version as shaft tie with M6 threaded tip.



Version with countersunk cone head and T drive.



Version with M8/M10 female thread sleeve for the connection of threaded rods.

Classification according to proof of application

F30

F60

F90

F120

System description

Anchoring type	Spread-free connection with self-tapping thread
Fire resistance classes	Up to F120 according to general type approval
Substrate	Concrete Masonry: Solid calcareous limestone brick, porous calcareous limestone brick, full brick

The data of the approval documents and any fire testing reports apply



MMS-plus SS hexagonal tie, with pressed washer

St G

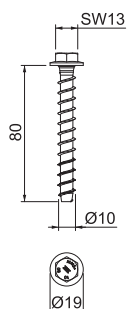
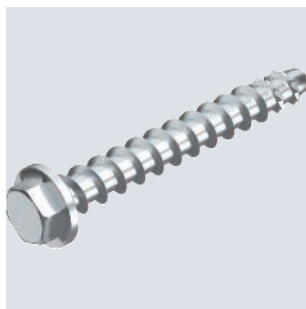

Type	Dimen- sion mm	Dim. L mm	Drill hole		Pack Piece	Weight kg/100 pc.	Item no.
			Ø	SW			
MMS+ SS 10x80	10x80	80	8	13	25	4.000	3498124
MMS+ SS 10x100	10x100	100	8	13	25	4.800	3498159

Bolt tie for direct mounting without additional anchors in cracked and uncracked concrete and masonry. With hex head drive and pressed washer to accept large loads. Suitable for fastening suspended loads from suspended supports and wall brackets. Construction product tested according to EAD and CE mark, with European Technical Assessment (ETA) and proof of suitability. Load-bearing capacities under fire loads proven up to fire resistance class R120.

MMS-plus P round head tie, with panhead

St G

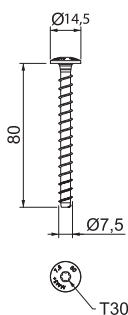

Type	Dimen- sion mm	Drill hole Ø	Head Ø	Screw system	Pack Piece	Weight kg/100 pc.	Item no.

Bolt tie for direct mounting without additional anchors in cracked and uncracked concrete and masonry. With round head for universal fastenings. Torx drive T30. Construction product tested according to EAD and CE mark, with European Technical Assessment (ETA) and proof of suitability. Load-bearing capacities under fire loads proven up to fire resistance class R120.

MMS-plus P round head tie, with panhead

St G

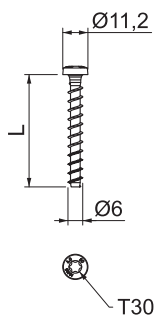
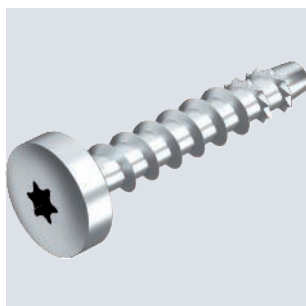

Type	Dimen- sion mm	Dim. L mm	Drill hole		Pack Piece	Weight kg/100 pc.	Item no.	
			Ø	Head Ø				
MMS+ P 6x35	6x35	35	5	11.2	Torx	100	0.710	3498103
MMS+ P 6x50	6x50	50	5	11.2	Torx	100	1.000	3498108

Bolt tie for direct mounting without additional anchors in cracked and uncracked concrete and masonry. With round head for universal fastenings. Torx drive T30. Construction product tested according to EAD and CE mark, with European Technical Assessment (ETA) and proof of suitability. Load-bearing capacities under fire loads proven up to fire resistance class R120.

MMS-plus MS mounting rail tie, with flat panhead

St G

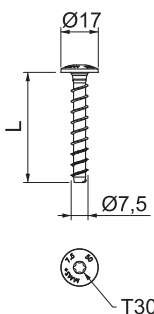
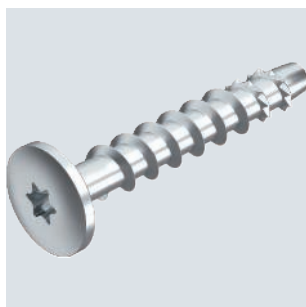

Type	Dimen- sion mm	Dim. L mm	Drill hole		Pack Piece	Weight kg/100 pc.	Item no.	
			Ø	Head Ø				
MMS+ MS 7.5x50	7,5x50	50	6	17	Torx	100	1.500	3498261

Bolt tie for direct mounting without additional anchors in cracked and uncracked concrete and masonry. With large round head to fasten mounting and profile rails. Torx drive T30. Construction product tested according to EAD and CE mark, with European Technical Assessment (ETA) and proof of suitability. Load-bearing capacities under fire loads proven up to fire resistance class R120.

St G

MMS-plus ST push-in tie, with connection thread

Type	Dimension mm	Drill hole Ø mm	Thread	SW mm	Pack Piece	Weight kg/100 pc.	Item no.
MMS+ ST 6x55	6x55	5	M6	10	100	1.030	3498264

Bolt tie for direct mounting without additional anchors in cracked and uncracked concrete and masonry. M6 connection thread for fastening clips with threaded foot. Construction product tested according to EAD and CE mark, with European Technical Assessment (ETA) and proof of suitability. Load-bearing capacities under fire loads proven up to fire resistance class R120.

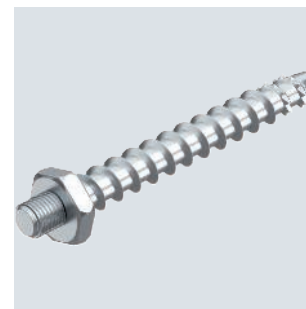
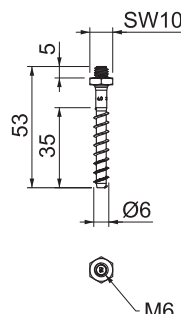

St G

MMS-plus I internal thread tie, with combination thread sleeve

Type	Dimension mm	Dim. L mm	Drill hole Ø mm	Thread	SW mm	Pack Piece	Weight kg/100 pc.	Item no.
MMS+ I 7.5x40	7,5x40	40	6	M8/M10	13	40	3.810	3498266
MMS+ I 7.5x60	7,5x60	60	6	M8/M10	13	40	4.230	3498268

Bolt tie for direct mounting without additional anchors in cracked and uncracked concrete and masonry. With M8/M10 combination thread sleeve for fastening threaded rods. Construction product tested according to EAD and CE mark, with European Technical Assessment (ETA) and proof of suitability. Load-bearing capacities under fire loads proven up to fire resistance class R120.

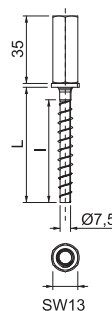

St G

Threaded rod

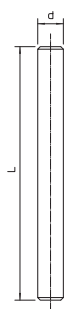
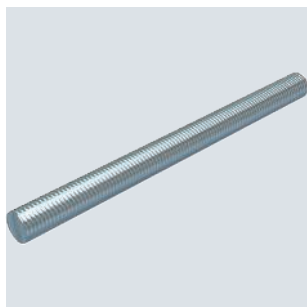

Type	Thread	Dim.		Pack Piece	Weight kg/100 pc.	Item no.
		d mm	L mm			
TR M8 1M G	M8	8	1000	10	30.000	3141128
TR M10 1M G	M10	10	1000	10	49.000	3141209

Threaded rod to DIN 976.

Connection sleeve

St G

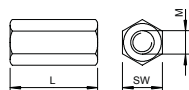

Type	Thread	Dim.		Pack Piece	Weight kg/100 pc.	Item no.
		L mm	SW mm			
CSTR M8 G	M8	24	13	50	1.880	6410081
CSTR M10 G	M10	30	17	50	4.150	6410103
CSTR M12 G	M12	40	19	25	7.000	6410111

Connection sleeve with continuous internal thread.

Washer

St G

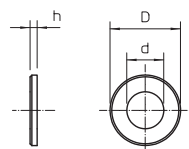
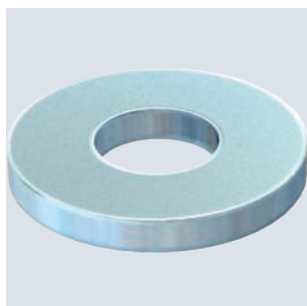







Type	Thread	Dim.			Pack Piece	Weight kg/100 pc.	Item no.
		d mm	D mm	h mm			
WS M10 D20 G	M10	10.5	20	2	100	0.408	3402096

Washer according to DIN 125, shape A, for universal use.











































Directories

	Test marks	118
	Pictogram explanation	120
	Alphabetical table of contents	124
	Type listing	126
	Numeric directory	128
	For the latest general conditions of sale and delivery please see www.obo.global/general-purchasing-conditions/	

























Test marks

	American Bureau of Shipping, USA		Underwriters Laboratories Inc., USA + CSA, Canada
	AENOR, Producto Certificado, Spain		Österreichischer Verband für Elektrotechnik, Austria
	STOWARZYSZENIE ELEKTRYKÓW POLSKICH, Poland		ISTITUTO ITALIANO DEL MARCHO DI QUALITÀ, Italy
	Lightning current-tested		RINA 1861, Ship Classification, Certification and Services
	Lightning current-tested, Class H (100 kA)		Underwriters Laboratories Inc., USA
	CEBEC, Belgium		SEMKO An Inchcape Testing Services Company, Sweden
	Canadian Standards Association, Canada		Eidgenössisches Starkstrominspektorat, Switzerland
	DEMKO, Danmarks Elektriske Materielkontrol, Denmark		South African Bureau of Standards
	Deutsches Institut für Bautechnik Berlin, Germany		Shock-tested, Bundesamt für Zivilschutz, Germany
	Det Norske Veritas		Sähkötarkastuskeskus Elinspektionscentralen Electrical Inspectorate, Finland
	ENEC Austria		Underwriters Laboratories Inc., USA
	ATEX certificate for explosive areas		Underwriters Laboratories Inc., USA
	ELEKTROTECHNICKÝ ZKUŠEBNÍ ÚSTAV, Czech Republic		Verband der Elektrotechnik, Elektronik, Informationstechnik e.V., Germany
	FIMKO, Finland		German Association of Electricians, tested safety
	Forschungs- und Materialprüfungsanstalt, Germany		5-year warranty
	Russia, GOST The State Committee for Standards		
	Test marks for technical resources, VDE Prüf- und Zertifizierungsinstitut Offenbach, Germany		
	Halogen-free; without chlorine, fluorine and bromine		
	INMETRO, Brazil		
	KEMA-KEUR, Netherlands		
	Indication of metric products		
	MAGYAR ELEKTROTECHNIKAI ELLENŐRZŐ INTÉZET Budapest, Hungary		
	NEMKO, Norway		
	AFNOR Quality symbol of the French standardisation institute		





Pictogram explanation





Surfaces

 FS	Strip galvanised
 FSK	Strip galvanised/plastic-coated
 DD	Strip galvanised zinc/aluminium, double dip
 BK	Bright
 2B	Bright, reworked
 EL	Anodised
 F	Hot-dip galvanised
 G	Electrogalvanised
 GK	Electrogalvanised/plastic-coated
 GCL	Electrogalvanised, yellow-chromatised
 GGP	Electrogalvanised, yellow passivated
 GTP	Electrogalvanised, transparently passivated
 GR	Primed
 L	Painted
 SG	Welding primed
 FT	Hot-dip galvanised
 FT SO	Hot-dip galvanised 85 µm
 Cu	Copper-plated
 N	Nickel-plated
 ZD	Galvanised, Deltatone 500
 ZDM	Galvanised, MAGNI 565
 GA	Zinc-aluminium coated, Galfan
 ZL	Zinc scale





Conformity symbol

	Communautés Européennes, EC declaration of conformity according to EC directives
	RoHS-conformant



















Quality marks

	Halogen-free; without chlorine, fluorine and bromine
	Flame resistant 650 °C
	Flame resistant 750 °C
	Flame resistant 960 °C
	UV-resistant



Specific product symbols

	Diameter 60 mm
	Diameter 68 mm
	Protection device to DIN EN 61643-11 or IEC 61643-11
	Transition from LPZ 2 to LPZ 3
	Acoustic signalling

Applications

	Remote signalling
	Acoustic signalling
	Integrated Service Digital Network, ISDN applications
	Digital Subscriber Line, DSL applications
	Analogue telecommunication
	Category 5 TwisterPair
	Channel Performance to American EIA/TIA standard
	Measuring, controlling and regulating systems
	TV applications
	SAT-TV applications
	MultiBase base
	LifeControl
	Intrinsically safe protection device for potentially explosive areas
	Channel Performance to ISO/IEC 11801
	Power over Ethernet
	230/400 V system
	Protection rating IP 54
	Protection rating IP 65

Lightning protection classes

	Protection device to DIN EN 61643-11 or IEC 61643-11
	Combination protection device made of type 1 and type 2
	Protection device to DIN EN 61643-11 or IEC 61643-11

Lightning protection classes

	Protection device to DIN EN 61643-11 or IEC 61643-11
	Protection device to DIN EN 61643-11 or IEC 61643-11

Lightning protection zone

	Transition from LPZ 0 to LPZ 1
	Transition from LPZ 0 to LPZ 2
	Transition from LPZ 0 to LPZ 3
	Transition from LPZ 1 to LPZ 2
	Transition from LPZ 1 to LPZ 3
	Transition from LPZ 2 to LPZ 3

BSS maintenance of electrical function installation

	Fire-tested systems
	Escape route ceiling mounting with pressure clip
	OBO Grip, wall routing type
	OBO Grip, ceiling routing type
	Pressure clip for maintenance of electrical function, ceiling mounting

BSS anchor

	Fire protection anchor
	Fire protection bolt tie

BSS test marks/material class

	Maintenance of electrical function class E30
	Maintenance of electrical function class E90

Clamp clip base shapes

	Clamp clip for C profile rail, slot width 11–12 mm
	Clamp clip for C profile rail, slot width 16–17 mm
	Clamp clip for C profile rail, slot width 18–22 mm

Diameter

	Diameter 60 mm
	Diameter 68 mm
	Diameter 70 mm
	Diameter 74 mm

Entries

	4 cable entries
	6 cable entries
	7 cable entries
	8 cable entries
	9 cable entries
	10 cable entries
	12 cable entries
	10 cable entries ECO
	12 cable entries ECO
	14 cable entries ECO
	16 cable entries
	18 cable entries ECO
	24 cable entries

Gland thread

	Thread metric
	Thread Pg

Entry size

	M20 entry
	M25 entry
	M32 entry
	M40 entry

KTS side heights









	Cable tray, side height 35 mm
	Cable tray, side height 60 mm
	Cable tray, side height 85 mm
	Mesh cable tray, side height 35 mm
	Mesh cable tray, side height 55 mm

Materials



	Flat steel
	Angular steel
	U steel
	Round material

Pictogram explanation





Nominal cross-section

	Nominal cross-section 1.5 mm ²
	Nominal cross-section 1.5–2.5 mm ²
	Nominal cross-section 2.5 mm ²
	Nominal cross-section 2.5–4 mm ²
	Nominal cross-section 4 mm ²
	Nominal cross-section 4–6 mm ²
	Nominal cross-section 6 mm ²
	Nominal cross-section 10 mm ²
	Nominal cross-section 16 mm ²













Nominal voltage

	Nominal voltage 400 V
	Nominal voltage 500 V
	Nominal voltage 660 V





Polarity

	3-pole
	5-pole
	7-pole
	8-pole
	10-pole
	12-pole



Slot widths

	Slot width 7.5 mm
	Slot width 11 mm
	Slot width 11–12 mm
	Slot width 12 mm
	Slot width 15 mm
	Slot width 16 mm
	Slot width 16.5 mm
	Slot width 16–17 mm
	Slot width 17 mm
	Slot width 18 mm
	Slot width 22 mm
	Slot width 35 mm











Screw heads

	Phillips screw
	Torx screw
	Phillips screw
	Pozidriv











Firing devices

	Bolt-firing tool
	Nail device





Protection rating

	Protection rating IP 20
	Protection rating IP 30
	Protection rating IP 31
	Protection rating IP 44
	Protection rating IP 54
	Protection rating IP 55
	Protection rating IP 65
	Protection rating IP 66
	Protection rating IP 67
	Protection rating IP 68

Metals

	Aluminium
	Aluminium/steel
	Stainless steel, rustproof
	Stainless steel, rustproof
	Stainless steel, rustproof
	Copper
	Brass
	Steel
	Malleable iron
	Die-cast zinc

Plastics

	Acrylonitrile butadiene styrene
	Duroplast, Aminoplast, type 131.5
	Duroplast, melamine resin, type 150
	Ethylene vinyl acetate

Plastics

FA	Fibre-proof material DIN 28091
GFK	Fibreglass-reinforced plastic
NBR SBR	Rubber mixture
NBR	Nitrile rubber
PETR	Petrolatum
PA	Polyamide
PA/ GF	Polyamide, fibreglass reinforced
PBPT	Polybutylene terephthalate
PC	Polycarbonate
PE	Polyethylene
PP	Polypropylene
PP/ GF	Polypropylene, fibreglass reinforced
PS	Polystyrene
PVC	Polyvinylchloride
ZELL PC	Cellular polyethylene



Alphabetical table of contents

9

90° Magic bend 60; 48, 96

A

Add-on tee 60; 48, 96

AML3518 anchor rail, slot 16.5 mm, perforated; 76

B

Black powder-coated steel pipe, without thread; 72

Black powder-coated steel sleeve, without thread; 72

Bolt tie BZ3; 108

C

Cable gland with locknut as a set; 28

Central hanger for cable tray, side height 60; 49

Central suspension; 50

Ceramic terminal; 28

Clamping piece for separating retainer fastening in; 54, 66, 102
RKSM

Closed FireBox T100, empty; 26

CML3518 profile rail, slot 17 mm, perforated; 76

Connection sleeve; 53, 103

Coupling nut; 114

D

DSK 25 spacer; 101

E

Electrogalvanised steel pipe, without thread; 72

Electrogalvanised steel sleeve, without thread; 72

End cap; 50-52, 65, 73, 97, 99-100

End caps; 50, 65, 97

F

Fender washer; 55

Fire protection bolt tie; 112

FireBox T100ED external fastening with fuse holder; 25

FireBox T100ED with external fastening; 24-25

FireBox T100ED with external fastening and 2 fuse; 25
holders

FireBox T100ED with external fastening, double; 24
terminals

G

GKS 34 hold-down clamp; 50, 65, 98

GR-Magic® 55 mesh cable tray; 49, 97

H

Head plate; 51

Hexagonal bolt with washer, serrated lock washer and; 54, 101
nut

Hold-down clamp for barrier strip fastening in GRM; 54, 66, 103

Hot-dip galvanised steel pipe, without thread; 73

Hot-dip galvanised steel sleeve, without thread; 73

J

Joint connector GSV 34; 50, 66, 98

M

Magic 60 straight connector set; 49, 97

MMS hex; 112

MMS-plusl bolt tie; 113

MMS-ST with thread; 113

Mounting rail MS4022, heavy-duty, slot 18 mm,; 77
perforated

Mounting rail, MS4141, slot 22 mm, perforated; 102

MS4121 mounting rail, slot 22 mm, perforated; 102

P

Pipe end cap, splittable, metric, black; 73

R

RKS-Magic® 60 cable tray; 48, 65, 96

S

Separating retainer; 53-54, 66, 102

Separating retainer connector; 53, 66

Spacer; 52, 80-81, 101-102

Spacer clip 732; 80

Spacer clip 733...; 80-81

Spacer DSK 45; 52, 102

T

Threaded rod; 53, 103, 114

Truss-head bolt with combination nut; 54

Truss-head bolt with nut and washer; 54

U

US 3 support; 99

US 3 suspended support; 50

US 5 head plate; 51

US 5 suspended support; 51, 100

US 7 suspended support; 52

W

Wall and support bracket AW 15; 52, 100

Wall and support bracket AW 30; 101

Wall and support bracket AWG 15; 53

Washer ISO 7093; 55, 103, 114



Type listing

Type	GTIN	Item no.	Page
129 TB M16 SW	6332335	/100 pc. 2047936	73
129 TB M20 SW	6332342	2047944	73
129 TB M25 SW	6332373	2047952	73
129 TB M32 SW	6332380	2047971	73
129 TB M40 SW	6332397	2047979	73
129 TB M50 SW	6332403	2047987	73
129 TB M63 SW	6332434	2047995	73
AML3518P2000FT	5047599	price/100 1119656	76
ASG 732 25 A4	6599813	1362472	80
ASL 733 25 A4	6600304	1362918	81
ASL 733 63 FT	6600014	1362738	80
AW 15 21 FT	6207190	/pc. 6420680	52
AW 15 21 FT	6207190	6420680	100
AW 15 31 FT	6207251	6420710	52
AW 15 31 FT	6207251	6420710	100
AW 15 41 FT	6207312	6420745	52
AW 15 41 FT	6207312	6420745	100
AW 30 61 FT	6206957	6419828	101
AW G 15 21 FT	6662531	6420608	53
AW G 15 31 FT	6662593	6420610	53
AW G 15 41 FT	6662654	6420612	53
BZ3 10x110/0-50	7357436	3498693	108
BZ3 8x75/0-20	7357238	3498683	108
CML3518P2000FS	5038771	price/100 1104500	76
CSTR M10 G	6202270	/100 pc. 6410103	53
CSTR M10 G	6202270	6410103	103
CSTR M10 G	6202270	6410103	114
CSTR M12 G	6202331	6410111	53
CSTR M12 G	6202331	6410111	103
CSTR M12 G	6202331	6410111	114
CSTR M8 G	6202218	6410081	103
CSTR M8 G	6202218	6410081	114
DIN440 11 F	6480074	6408729	55
DSK 25 FT	6229277	/pc. 6416446	101
DSK 45 FT	6202812	6416500	52
DSK 45 FT	6202812	6416500	102
DSK 61 FT	6202874	6416519	52
FRS 10x25 F	6201792	/100 pc. 6407528	54
FRSB 6x12 F	6199815	6406122	54
FRSB 6x20 F	6199990	6406203	54
GKS 34 A2	6013456	/pc. 6016839	65
GKS 34 A4	6120437	6016859	65
GKS 34 G	7261436	6016855	50
GKS 34 G	7261436	6016855	98
GMS 170 FS	6940875	6015400	50
GR KS 3.9 OR	5872887	/100 pc. 6003750	50
GR KS 3.9 OR	5872887	6003750	97
GR KS 4.8 OR	5872894	6003754	65
GR KS 4.8 OR	5872894	6003754	50
GR KS 4.8 OR	5872894	6003754	97
GRM 55 100 G	6858552	price/m 6001442	97
GRM 55 100 G	6858552	6001442	49
GRM 55 150 G	6078974	6001444	49
GRM 55 200 G	6858613	6001446	97
GRM 55 200 G	6858613	6001446	49
GRM 55 300 G	6858675	6001448	97
GRM 55 300 G	6858675	6001448	49

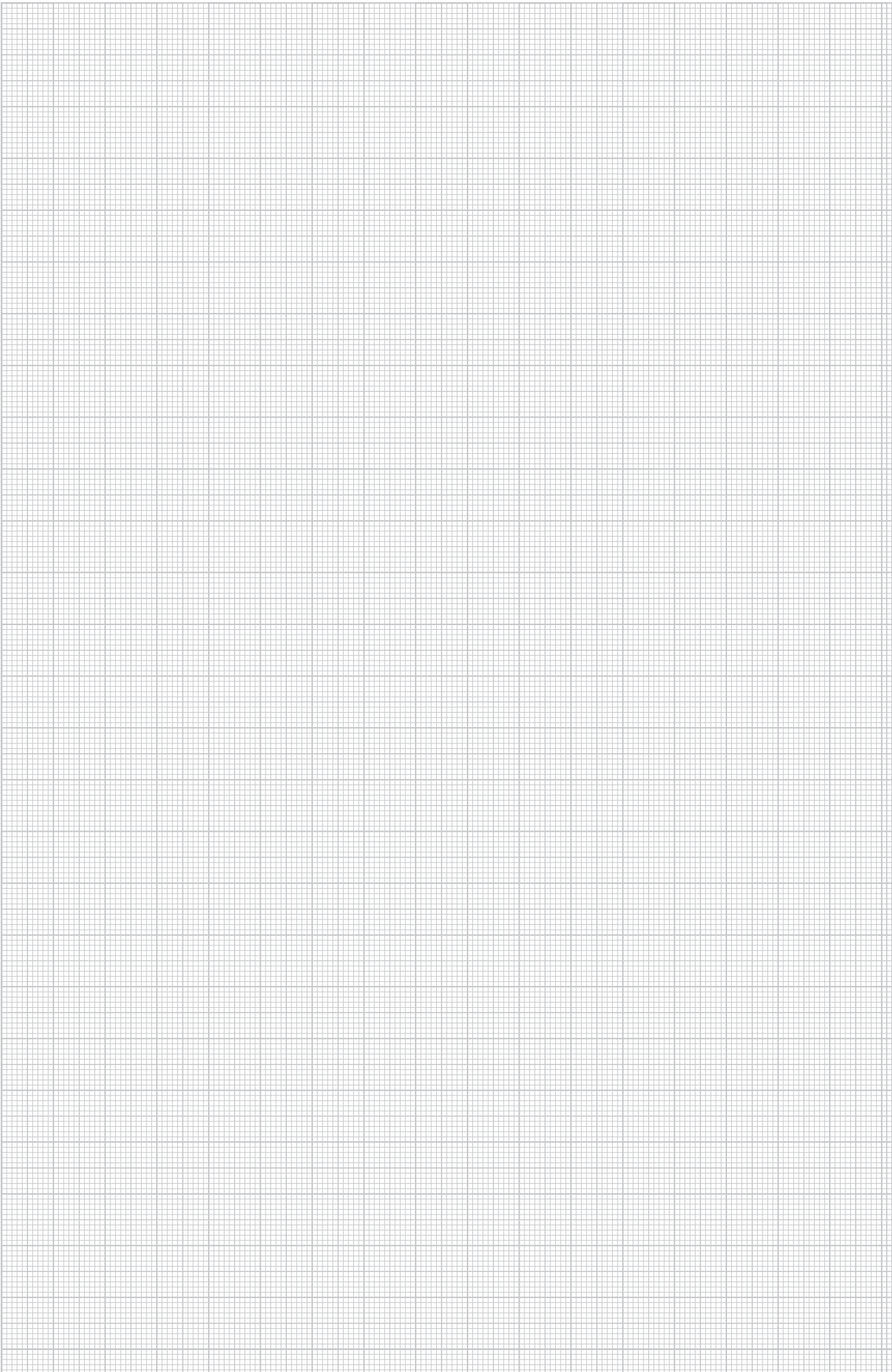





© OBO Bettermann 07/2023 NO

OBO Bettermann AS

Hvamveien 4
2013 Skjetten

www.obo-bettermann.no

Kundeservice Norge

Tlf.: +47 64 80 22 22
info@obo-bettermann.no

Building Connections

