



Insulation & cable bandages

Building Connections

Digitalisation, the Energiewende (energy transition), mobility – the future is gathering speed. At OBO Bettermann, we're proud to be a driving force. And as a facilitator, we make connections. Today, we are already developing the innovative electrical infrastructure systems and solutions of tomorrow. Reliably, flexibly, sustainably.

Already today, OBO is one of the leading manufacturers of installation systems for the electrical infrastructure in buildings and plants. When it comes to the friction-free flow of power, energy and data, engineers and tradespeople worldwide rely on the comprehensive range from OBO.



OBO applies its slogan "Building Connections" to around 30,000 high-quality branded electrical products and services, which are used in application solutions for projects in industry, business and infrastructure.

OBO operates a global network and employs more than 4,200 people in more than 60 countries. The headquarters of the family company, which was founded in 1911, is located in Menden, Germany. In addition, more than 40 subsidiaries are present in markets on all continents.



Improved structure, sharpened profile



Each of our products carries a benefit which only the OBO brand can offer. Products are developed, manufactured and tested with a high level of competence – from the idea through to the final check. From flawless logistics through to practical information – we can provide support at every level. We can offer additional security through certificates on the conformity of our products with the most important standards and directives. In a nutshell – OBO helps you more. In every location and in every phase of a project.

To maintain this, we continually challenge ourselves. Not as an end in itself but for the better processing of each customer's requests – fast, reliably and future-oriented. That is the reason we have not only established our three central application areas, but also reworked our catalogue structure. In this way, we can display our service offers more clearly, highlight the product benefits more effectively and illustrate the respective application areas more tangibly.

OBO Product Worlds



Industrial installations

- Cable support systems
- Connection and routing systems
- Fastening material



Building installations

- Cable routing systems
- Device installation ducts, trunking and poles
- Floor installation systems and underfloor applications
- Installation systems



Safety and protection installations

- Surge protection
- External lightning protection
- Equipotential bonding and earthing
- Insulation and cable bandages
- Fire-tested support and routing systems
- Fire protection ducts



It's your choice – from now on there's a catalogue for each OBO product category. Simply select the catalogues and order together with a collection case.

OBO Support & *contact*

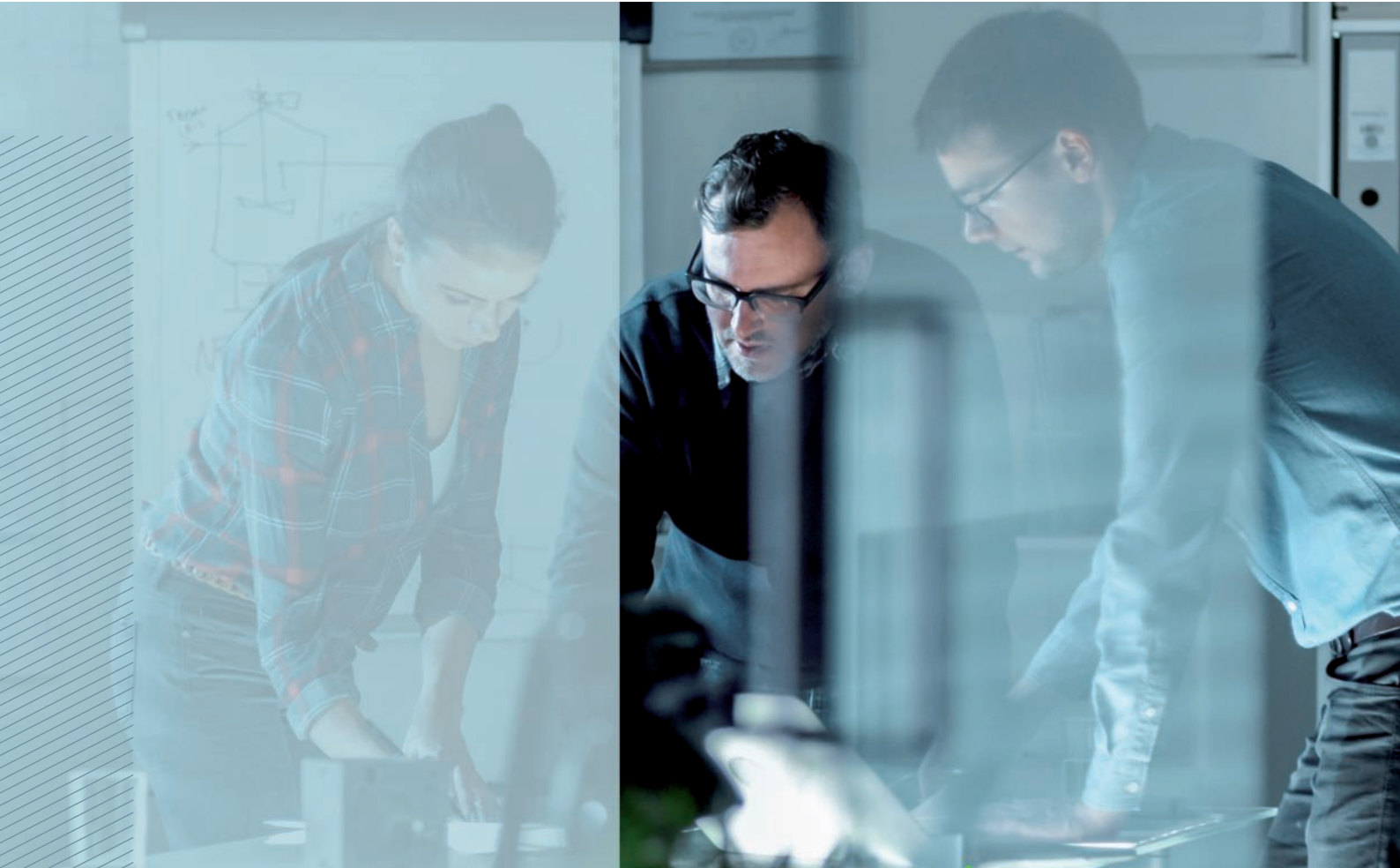

***You have a
problem?
We have the
solution!***

OBO Bettermann is more than the sum of its products. In any situation, we are the reliable partner right by your side. You have a problem? We have the solution!

It doesn't matter in which area of industry our support is needed – from industrial and plant engineering to private, public and administrative buildings, as well as in the areas of mobility and renewable energies – we have everything that you need.

OBO can not only provide the entire electro-technical infrastructure with the best possible products. We can also support you with sound expert knowledge and more than 100 years of experience, right from the planning phase through to the realisation of your projects. OBO – solutions you can rely on.

What is OBO Support?

Every OBO product carries a plus inside it, which only a branded product can offer. It is developed, manufactured and tested with a high level of competence, from the idea right through to the final check. In addition, our specialists are available for consultation and can offer you assistance and training courses for products at any time.

Together with you, we plan your project and help you choose the right products, and are also available to you at any time should you need us. From flawless logistics through to practical information – we can provide support at every level. We can offer security through certificates on the conformity of our products with the most important standards and directives.

We are as flexible as you are – because we know how practical people work and what is important to them. Each step is a plus – that is the OBO Support concept.

You can contact our Customer Service department on:

Customer Service

Tel.:+49 23 73 89 - 17 00

Monday–Thursday
07.30–17.00

export@obo.de



Service



Training



Handling



Certification

Service – OBO can help

Everywhere and in every project phase:

- Highly competent hotline
- Product and system information, digitally or printed
- Selection and planning aids on the web, as an app, as a CAD application or in printed form
- 2D and 3D product data for planning
- Field service, branch offices and subsidiaries in 60 countries
- Engineering services for major projects

Training courses from OBO

- Seminars and workshops
- Local consultation and training courses
- Planner days

Handling – OBO delivers reliably

With optimised delivery processes:

- Reliable logistics
- Practical transport systems and packaging
- Loading gear handling and disposal concepts

Certification and guarantee

OBO offers safety. Our products fulfil the most important country-specific regulations:

- Conformity (e.g. IEC, VDE, CE, KEMA, KEUR, UL)
- Certification (e.g. DIN EN, DGNB)
- 5-year guarantee for surge protection products
- Guarantee management



Planning aids

Page 10



Insulation, maintenance of the fire sections

Page 20



Cable bandages, prevention of the spread of fire

Page 92

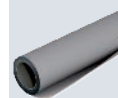

Fire protection duct for roof structures, to prevent the spread of fire

Page 98

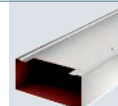

Directories

Page 104





Planning aids

First protection aim: Maintenance of the fire sections	12
Insulation systems	13
Second protection aim: Protection of escape routes	14
Escape route installations	15
Third protection aim: Function maintenance for electrical systems	16
Systems for the maintenance of electrical function	17
Technical support	18



First protection aim: Maintenance of the fire sections



Insulation systems reliably seal the ceiling and wall penetrations required for installations against fire and smoke.

The division of buildings into fire sections protects unaffected building sections against the spread of fires for specific periods of time. Insulation maintains the fire sections, thus limiting the spread of fire and smoke. These constructive measures protect people and property, allowing fire brigades to prevent the spread of fires to other parts of the building through extinguishing measures.

Function of firewalls

Firewalls should ensure that a fire cannot pass to neighbouring buildings or building sections. This creates so-called fire sections. The construction design of these firewalls (materials, fire resistance classes, stress values) is regulated by building regulations and standards.

Electrical cables and pipes may only be run through walls and ceilings at the ends of rooms when there is a guarantee that they do not present an opportunity for fire and smoke to spread. Insulation systems reliably seal the ceiling and wall penetrations required for installations against fire and smoke.

Special requirements

The following requirements apply to cable penetrations with cable insulation:

- The spread of fire and smoke must be prevented
- Room closure must be guaranteed
- On the side of the insulation away from the fire, the surfaces of cables, pipes, cable support systems and the surface of the insulation may not heat up to an impermissible level

Insulation systems and cable bandages



Mortar insulation systems

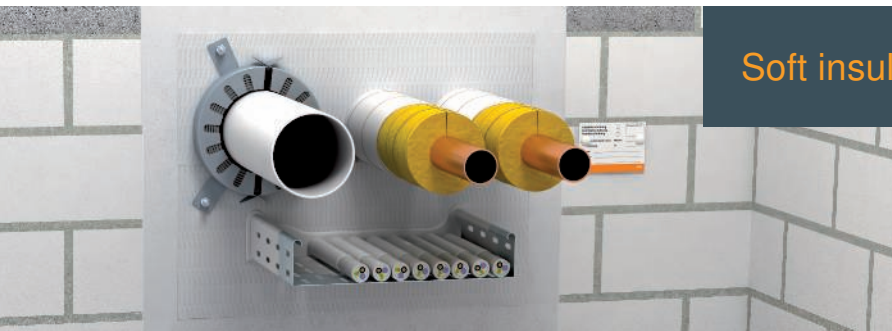

Soft insulation systems



Foam systems



Pipe shell systems



Cable bandages

Schutzinstallationen - Verschlösungen und Kabelbänder - Verhinderung der Brandweiterleitung / en / 2023/07/24 14:17:58 14:17:58

Second protection aim: Protection of escape routes



2

Approximately 95% of all deaths during fires are caused by smoke poisoning! In case of fire, emergency and escape routes are the central lifeline of the building and must remain usable under all circumstances.

What is an emergency and escape route?

According to the construction regulations, there must be routes in buildings which not only permit access to the building in a horizontal and vertical direction in normal situations, but which also offer the option of rescue in case of fire. It is therefore obligatory to equip buildings with at least one constructive emergency and escape route. Additional emergency and escape routes may also be necessary, depending on the type of building.

These include:

- Necessary staircases (vertical access)
- Connecting rooms between the necessary stairwells and exits to the outside
- Necessary corridors (horizontal access)

There must be a guarantee that, if there is a fire, these routes can be used to leave the building without any risk. In addition to evacuation, the emergency and escape routes also aid the local fire brigades as a point of attack.

In the area of emergency and escape routes, an installation may not pose an additional fire load. This requirement can be fulfilled using an appropriate type of installation:

- Concealed installation
- Installation in fire protection duct systems
- Installation above suspended fire protection ceilings
- Use of non-combustible materials
- Routing of cables with improved behaviour in case of fire

Escape route installations

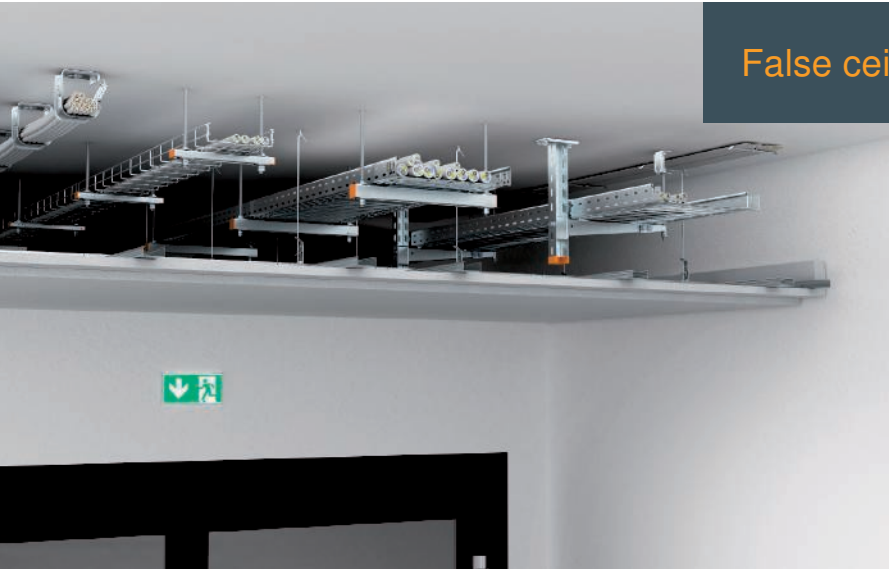

False ceiling mounting

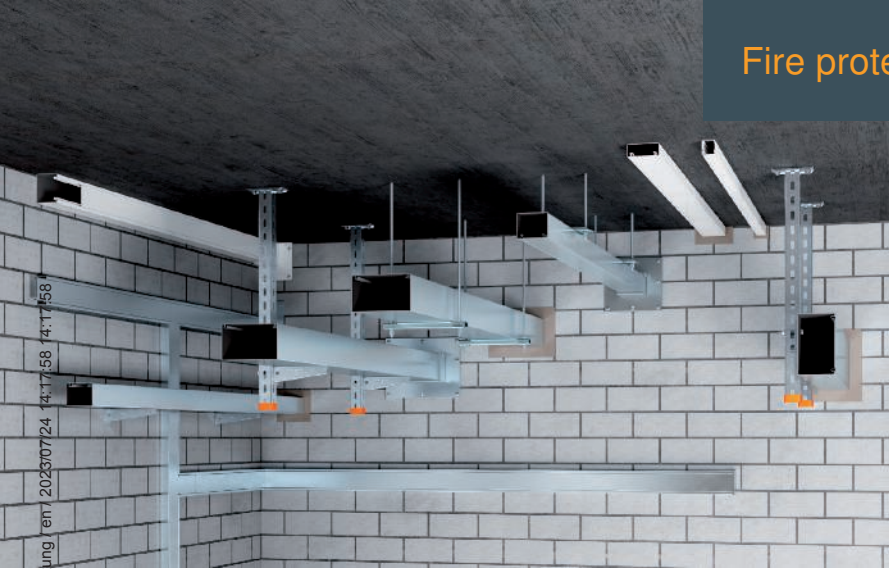

Fire protection ducts, metal

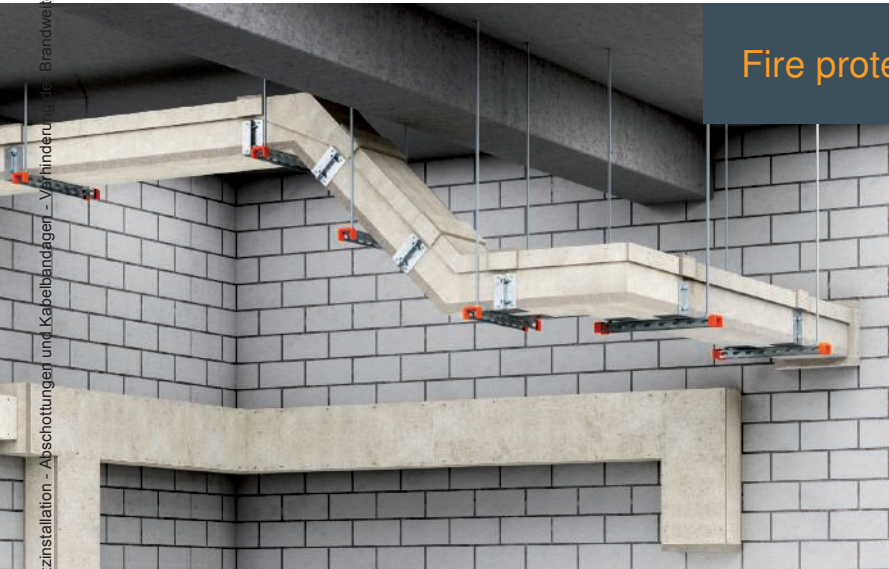

Fire protection ducts, concrete

Schutzinstallation - Abschottungen und Kabelbänder - Verhindern des Brandweiterleitung - 2023/07/24 14:17:58 4:17:58

Third protection aim: Maintaining the functionality of electrical systems



3

E30

E90

If there is a fire, emergency and escape routes must remain usable and important technical equipment, such as emergency lighting, fire alarm systems and smoke extraction systems, must continue to function. Therefore, it is essential that the power supply for these systems is specially protected. In addition, certain technical systems must support the fire brigades in fighting fires for a sufficiently long period of time.

Where is the maintenance of electrical function required?

Technical equipment with maintenance of electrical function is required for the following buildings and systems:

- Hospitals
- Hotels and restaurants
- Tower blocks
- Meeting points
- Commercial buildings
- Closed large garages
- Underground railway systems
- Chemicals industry
- Power stations
- Tunnels

This could be because these constructions are regularly frequented by many people, which creates an increased safety risk for gatherings of people. However, with certain systems, property and the environment must also be protected.

30 minutes: Maintenance of electrical function for safe evacuation and rescue

The first 30 minutes after the start of a fire play an important role. For the affected building to be cleared quickly the maintenance of electrical function must be guaranteed for the following equipment during this time:

- Safety lighting systems
- Lifts with fire control
- Fire alarm systems
- Alarm systems and systems to issue instructions
- Fire extraction systems

90 minutes: Maintenance of electrical function for effective firefighting

To support firefighting operations, it is imperative that certain technical equipment is supplied with sufficient power even up to 90 minutes after a fire breaks out in a building. This equipment includes:

- Water pressure increase systems for fire water supply
- Mechanical smoke extraction systems and smoke protection pressure systems
- Fire brigade lifts
- Bed lifts in hospitals and similar equipment

Systems that maintain the electrical function



Cable trays and cable ladders



Vertical ladders



Individual routing

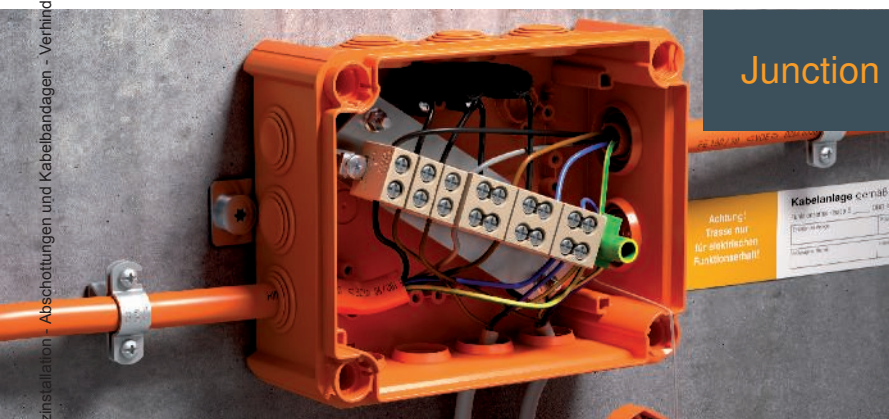

Junction boxes

Schutzinstallation - Abschottungen und Kabelbandagen - Verhinderung der Brandweiterleitung / en / 2023/07/24, 14:17:58 14:17:58

Technical support



OBO BSS seminars: First-hand knowledge

With a comprehensive programme of training courses and seminars on the subject of fire protection systems, OBO is able to support its customers with specialist knowledge from a single source. Alongside the basic theoretical principles, the programme also deals with practical implementation in everyday applications. Special calculation and application examples round off the comprehensive programme of knowledge transfer.



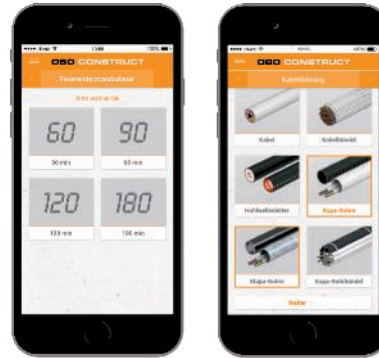

The OBO construct BSS online Tool

It works on any computer with Internet access. The BSS software simplifies the planning of suitable fire protection systems. After the basic data has been entered, the user obtains an overview of the approved insulation systems, as well as of any necessary and optional system accessories. Thus, they can create, edit and export a personal shopping list in a targeted manner. All the key information on standards and approvals can be found directly with the systems.

BSS app

The OBO Construct BSS app makes finding the right product even quicker. In only a short time, the app determines the fire protection systems required for the appropriate project. It offers the full scope of the Construct BSS module, allowing simple planning and material calculations in any location. It's extremely practical, as the parts list can be sent directly by e-mail. The app is available for Android and Apple devices from Google Play Store and the iTunes App Store.









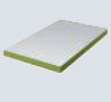

Fire protection guide for electrical installations

In the second edition of the fire protection guide, we have again compiled lots of useful information. The interconnections of fire protection between different types of technical building equipment are now explained in even more detail. Perhaps you will find some new information in this edition which can help you in the planning and implementation of fire protection systems.

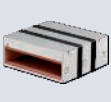

Would you like an overview
of all certificates?
Simply scan the QR code.

Insulation, maintenance of the fire sections

	PYROMIX® mortar insulation	22
	PYROPLATE® Fibre soft insulation	28
	PYROBAG® fire protection cushion insulation	34
	PYROSIT® NG fire protection foam	40
	Fire protection box PYROPLUG® MagicBox	44
	PYROPLUG® foam series	50
	PYROCOMB® pipe sleeve	72
	PYROCOMB® Intube pipe shell	78
	PYROMIX® Screed small insulation	82
	Conlit bandage for cable bundles	86
	Single cable lock according to MLAR	90

PYROMIX® mortar insulation

System description

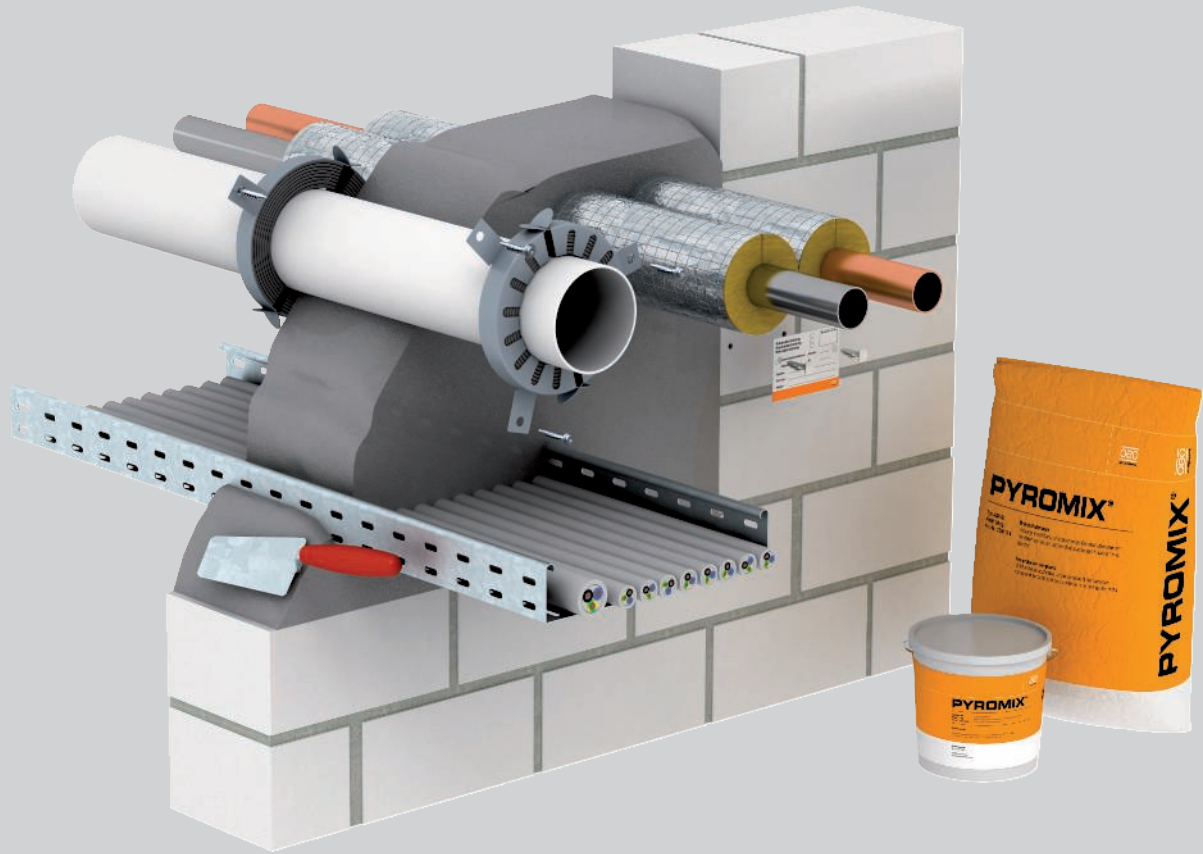

The PYROMIX® system from OBO is used to create cable and combination insulation made of a mineral fibre-free special mortar. Depending on the amount of water added, the finished compound can be applied to openings by hand, with pumps or with presses. The high level of substrate

adhesion makes lining unnecessary for small insulation areas. The porous consistency of the mortar means that reinstallation is easy. If there is a fire, the fire protection mortar reliably prevents the spread of fire and smoke.

PYROMIX® mortar insulation

Installation principle



Stir the mortar with water until the desired consistency is reached.



Apply mortar to the opening, use lining as necessary.



Use approved section insulation for metal pipes.



Section insulation should also be applied to steel electrical installation pipes.



Mount pipe sleeves for combustible pipes on both sides of the wall.



Apply labelling to combination insulation for various structures.

Classification to EN

S30

S60

S90

Classification to EN

EI15

EI30

EI45

EI60

EI90

EI120



Erectors of combination insulation systems have to be trained.

PYROMIX® mortar insulation





Registration data

Combination insulation in walls/ceilings

Fire resistance class	EI 180, EI 240
Proof of application	European Technical Assessment of DIBt, Berlin
Approval number	ETA-17/0472
Testing standard	EN 1366-3

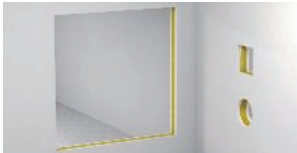
Areas of installation

Insulation systems in walls/ceilings

Component		Rigid walls	Flexible walls	Rigid floors
				
Min. component strength		15 cm (EI 60 / EI 90 / EI 120)	-	15 cm
Min. insulation thickness		15 cm (EI 60 / EI 90 / EI 120) 24 cm (EI 120)	-	15 cm (EI 60 / EI 90 / EI 120) 24 cm (EI 120)
Opening size		↔ ≤ 120 cm (for EI 120) ↓ ≤ 200 cm	-	↔ ≤ 100 cm ↓ Unlimited
		↔ 120 cm (for EI 120) ↓ ≤ 60 cm x ≤ 60 cm	-	↔ 120 cm (for EI 120) ↓ ≤ 60 cm x ≤ 60 cm

PYROMIX® mortar insulation Installations

Cable

Ø 80 mm ✓ 

Pipe bundle of electrical installation pipes

Only with PYROCOMB® Intube ✓ 

Cable bundle

Ø 100 mm, cable Ø 21 mm ✓ 

Electrical installation pipe made of steel

Ø 16 mm, cable Ø 16 mm ✓ 

Individual lines for control purposes

✗ 

Cable support systems

Steel profiles ✓ 

Electrical installation pipe made of plastic, rigid

Ø 16 mm, cable Ø 21 mm ✓ 

Metal pipes with path insulation

Steel, stainless steel and cast steel Ø 323.9 mm, copper Ø 108.0 mm ✓ 

Electrical installation pipe made of plastic, flexible

Only with PYROCOMB Intube ✓ 

Plastic pipes

Ø 160 mm ✓ 

Special installations

Double solar pipes

Stainless steel with insulation + accompanying cable Ø 40 mm (Ceiling 30 min.) ✓ 

Speed pipe

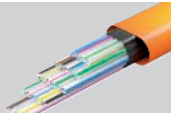
24 pipes Ø 7 mm x 1.5 m, 7 pipes Ø 10 mm x 2.0 m, 5 pipes Ø 12 mm x 2.0 mm, Ø 50 mm total ✓ 

Klimasplit

Tubolit Duo Split Ø 6.0–18.0 mm ✓ 

Hydraulic hoses

HANSA-FLEX HD 200-2 SN Ø 55.9 mm (150 mm component) ✓ 

 Details on the version can be found in the proof of suitability or mounting instructions. All the stated dimensions are maximum values.

Threaded rod

St G



Type	Thread	Dim.	Dim.	Pack	Weight	Item no.
		d	L			
TR M8 1M G	M8	8	1000	10	30.000	3141128

Threaded rod to DIN 976.

MMS-plus P round head tie, with panhead

St G

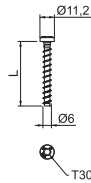
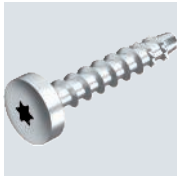

Type	Dimen- sion	Dim. L	Drill hole			Screw system	Pack Piece	Weight kg/100 pc.	Item no.
			Ø	Head Ø	mm				
MMS+ P 6x35	6x35	35	5	11.2	Torx	100	0.710	3498103	
MMS+ P 6x50	6x50	50	5	11.2	Torx	100	1.000	3498108	

Bolt tie for direct mounting without additional anchors in cracked and uncracked concrete and masonry. With round head for universal fastenings. Torx drive T30.
Construction product tested according to EAD and CE mark, with European Technical Assessment (ETA) and proof of suitability. Load-bearing capacities under fire loads proven up to fire resistance class R120.

MMS-plus MS mounting rail tie, with flat panhead

St G

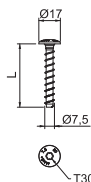

Type	Dimen- sion	Dim. L	Drill hole			Screw system	Pack Piece	Weight kg/100 pc.	Item no.
			Ø	Head Ø	mm				
MMS+ MS 7.5x50	7,5x50	50	6	17	Torx	100	1.500	3498261	

Bolt tie for direct mounting without additional anchors in cracked and uncracked concrete and masonry. With large round head to fasten mounting and profile rails. Torx drive T30.
Construction product tested according to EAD and CE mark, with European Technical Assessment (ETA) and proof of suitability. Load-bearing capacities under fire loads proven up to fire resistance class R120.





Soft insulation, PYROPLATE® Fibre System description



The PYROPLATE® Fibre system from OBO is used to create cable and combination insulation. The core of the system is the mineral fibre plate coated with a moisture-resistant ablation coating. When there is a fire, the fire protection coating creates an insulating carbon foam and, in combination with the mineral fibre plate, prevents the spread of fire and smoke. According to the construction

approval, in addition to the cables, pipes made of steel, copper or various plastics may also be run through the same insulation. For pipelines, additional fire protection measures, such as section insulation and pipe sleeves, are required. The mortar or soft insulation made of PYROPLATE® Fibre is thus combination insulation which is appropriate for diverse structures.

Soft insulation, PYROPLATE® Fibre

Installation principle



The installation is possible in light-duty partition walls or in solid walls.



Moisten the component layer and apply the coating to the cut edges for adhesion.



The plates can be inserted carefully with a hammer and board.



Use approved section insulation for metal pipes.



Apply the final coating to the surface and the installations.



Fix pipe sleeves for combustible pipes with threaded rods on both sides.



Combination insulation for various structures with labelling.



Secure soft insulation in ceilings against footfall.

Classification to EN

S30

S60

S90

Classification to EN

EI15

EI30

EI45

EI60

EI90

EI120

EI180

EI240



Erectors of combination insulation systems have to be trained.

Soft insulation, PYROPLATE® Fibre

Registration data

Combination insulation in walls / ceilings





Fire resistance class	Fire-resistant (90 minutes)
European Technical Assessment	ETA-17/0364 (PYROCOAT® ASX)
General type approval	Z-19.53-2611
Test standard	DIN EN 1366-3
Classification standard	DIN EN 13501-2
Declaration of performance	05-DOP-002

Note:

For the legally compliant documentation, the European Technical Assessment (ETA), the general design approval (aBG) and the declaration of performance (DoP) are needed. The labelling of the insulation system and the submittal of the declaration of conformity statement are mandatory after the installation. All certificates and a sample of the declaration of conformity statement that can be edited are available from the download area at www.obo.de.

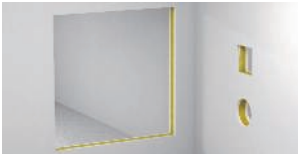
Areas of installation

Insulation systems in walls/ceilings

Component		Rigid walls	Flexible walls	Rigid floors
				
Min. component strength		10 cm	10 cm	15 cm
Min. insulation thickness		10 cm	10 cm	10 cm
Opening size		↔ ≤ 120 cm, ↕ ≤ 200 cm	↔ ≤ 120 cm, ↕ ≤ 200 cm	↔ ≤ 125 cm, ↕ unlimited
		↔ ≤ 200 cm, ↕ ≤ 120 cm	↔ ≤ 200 cm, ↕ ≤ 120 cm	

Soft insulation, PYROPLATE® Fibre Installations

Cable

All Ø ✓ 

Pipe bundle of electrical installation pipes

Only with PYROCOMB® Intube ✓ 

Cable bundle

Ø 100 mm, cable Ø 21 mm ✓ 

Electrical installation pipe made of steel

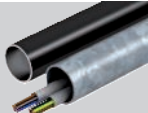
Two steel and copper pipes Ø 6-15 mm with insulation ✓ 

Individual lines for control purposes

Ø 15 mm ✓ 

Cable support systems

Profiles made of steel, aluminium or plastic ✓ 

Electrical installation pipe made of plastic, rigid

✗ 

Metal pipes with path insulation

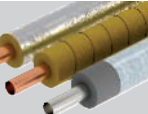
Steel, stainless steel and cast steel Ø 219.1 mm, copper Ø 88.9 mm ✓ 

Electrical installation pipe made of plastic, flexible

Ø 32 mm, cable Ø 21 mm ✓ 

Plastic pipes

Ø 160 mm ✓ 

Special installations

Speed pipe

24 pipes Ø 7 mm x 1.5 mm, 7 pipes Ø 12 mm x 2.0 mm, Ø 50 mm in total ✓ 



Details on the version can be found in the proof of suitability or mounting instructions. All the stated dimensions are maximum values.

Mineral fibre plate, pre-coated

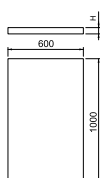
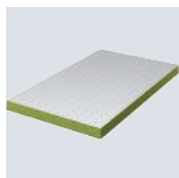

Type	Length	Width	Height	Pack Piece	Weight kg/100 pc.	Item no.
	mm	mm	mm			
PSX-P60	1000	600	60	4	540.000	7202297

Mineral fibre plate, pre-coated with the PYROCOAT® ASX ablation coating, as the basis for the PYROPLATE® Fibre soft insulation system. 50 mm plate for insulation according to German approval, 60 mm plate for insulation according to European approval. For interior application.

Threaded rod

St G



Type	Thread	Dim. d	Dim. L	Pack Piece	Weight kg/100 pc.	Item no.
		mm	mm			
TR M8 1M G	M8	8	1000	10	30.000	3141128

Threaded rod to DIN 976.



PYROBAG® fire protection cushion insulation

System description

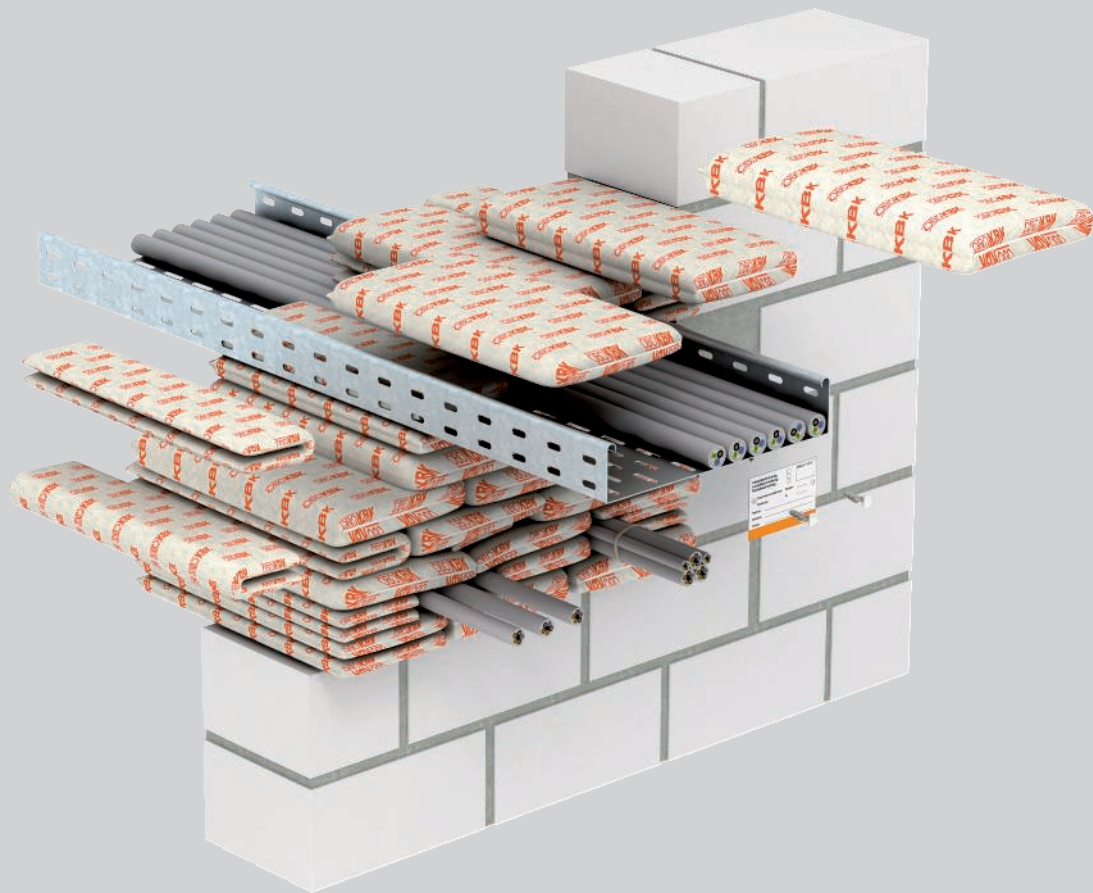

The PYROBAG® system from OBO is used to create cable insulation from fire protection cushions. The fire protection cushions, which can be shaped in any way, are stacked simply and quickly on top of each other, allowing absolutely tidy and dust-free mounting. The cushions can be used for permanent or temporary insulation in walls and ceilings, e.g. during renovations. The fire protection cushions are an ideal solution for

frequent re installations. Additional cables can be installed quickly, neatly and economically at a later date because the cushions can be used several times over. The cushions consist of a close-knit, dense and mechanically solid glass fabric with a special filling. The shell and the filling are free of mineral fibres and are also weatherproof and waterproof. Neither painting nor the use of filler are required.

PYROBAG® fire protection cushion insulation

Installation principle



Closing of the opening with cushions – without filler or coating.



Panels as mounting aid for the last cushion layer.

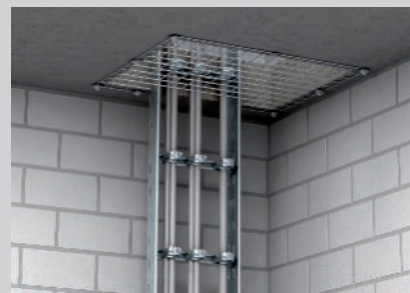

Lock against falling out during ceiling mounting.



Lock against slippage above the floor.



Cushions arranged in the duct.



Retaining profile to prevent slippage in vertical arrangements.



Discreet attachment of the identification plate.

Classification to EN

- EI30
- EI60
- EI90



Erectors of combination insulation systems have to be trained.

PYROBAG® fire protection cushion insulation

Registration data

Insulation in walls/ceilings









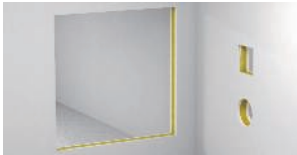

Fire resistance class	Fire-resistant (90 minutes)
European Technical Assessment	ETA-18/1069
General type approval	Z-19.53-2570
Test standard	DIN EN 1366-3
Classification standard	DIN EN 13501-2
Declaration of performance	05-DOP-013

Note:



For the legally compliant documentation, the European Technical Assessment (ETA), the general design approval (aBG) and the declaration of performance (DoP) are needed. The labelling of the insulation system and the submittal of the declaration of conformity statement are mandatory after the installation. All certificates and a sample of the declaration of conformity statement that can be edited are available from the download area at www.obo.de.

Areas of installation

Insulation systems in walls/ceilings

Component		Rigid walls	Flexible walls	Rigid floors
				
Min. component strength		10 cm	10 cm	15 cm
Min. insulation thickness		35 cm	35 cm	35 cm
Opening size		 ≤ 100 cm,  ≤ 150 cm	 ≤ 100 cm,  ≤ 100 cm	 ≤ 60 cm,  unlimited

Insulation in cable ducts

Component		Rigid walls	Flexible walls	Rigid floors
				
Min. insulation thickness		10 cm	10 cm	15 cm
Duct size		35 cm	35 cm	35 cm
Plastic ducts		21 cm x 10 cm	21 cm x 10 cm	21 cm x 10 cm
Metal ducts		21 cm x 8 cm	21 cm x 8 cm	21 cm x 8 cm

PYROBAG® fire protection cushion insulation

Installations

Cable



Pipe bundle of electrical installation pipes



Cable bundle



Electrical installation pipe made of steel



Individual lines for control purposes



Cable support systems



Electrical installation pipe made of plastic, rigid



Metal pipes with path insulation



Electrical installation pipe made of plastic, flexible



Plastic pipes



Special installations

Plastic ducts

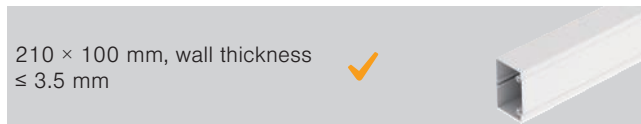

Insulation in the lining pipe

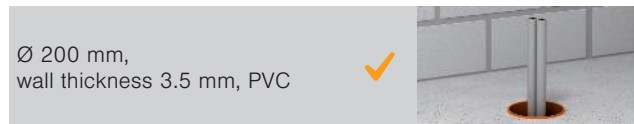

Metal ducts

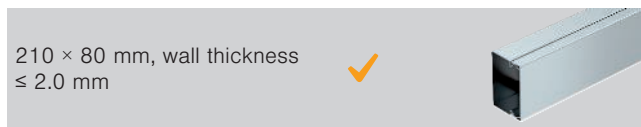

Details on the version can be found in the proof of suitability or mounting instructions. All the stated dimensions are maximum values.

MMS-plus MS mounting rail tie, with flat panhead

St G

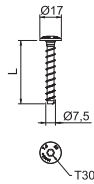

Type	Dimension mm	Dim. L mm	Drill hole		Screw system	Pack Piece	Weight kg/100 pc.	Item no.
			Ø	Head Ø				
MMS+ MS 7.5x50	7,5x50	50	6	17	Torx	100	1.500	3498261

Bolt tie for direct mounting without additional anchors in cracked and uncracked concrete and masonry. With large round head to fasten mounting and profile rails. Torx drive T30.
Construction product tested according to EAD and CE mark, with European Technical Assessment (ETA) and proof of suitability. Load-bearing capacities under fire loads proven up to fire resistance class R120.



PYROSIT® NG fire protection foam System description

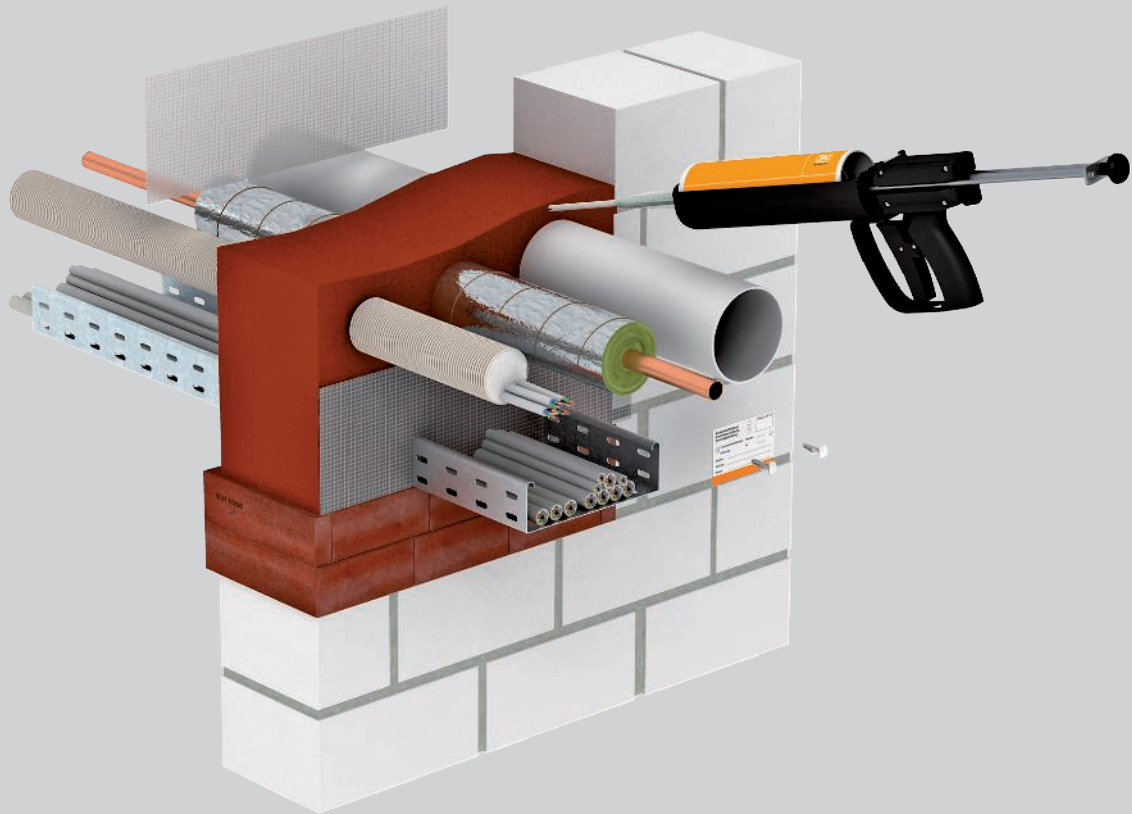

The PYROSIT® NG fire protection foam system from OBO is used to create cable and combination insulation made of fire protection foam. The special recipe of the 2-component foam allows simple, "pinpointed" processing. The good substrate adhesion prevents the foam from running out of the opening. Work can easily be interrupted to carry out checks. The system can be installed without dust and fibres. Surface coating is not necessary.

According to the construction approval, in addition to the cables, pipes made of steel, copper or various plastics may also be run through the same insulation. The PYROSIT® NG insulation is suitable as combination insulation for different units. Due to the soft consistency, the insulation made of PYROSIT® NG can be reassigned simply. The insulation system can be combined with the PYROPLUG® Block foam block.

PYROSIT® NG fire protection foam

Installation principle



Clean the layer and attach the lining aids, e.g. adhesive tape.



Apply the foam from the rear to the front, and remove residues as necessary.



Use approved section insulation for metal pipes.

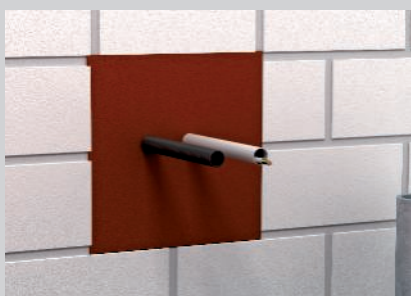

Electrical installation pipes up to M40, filled with cables or empty.



Combustible pipes up to Ø 50 mm can be run through without additional measures.

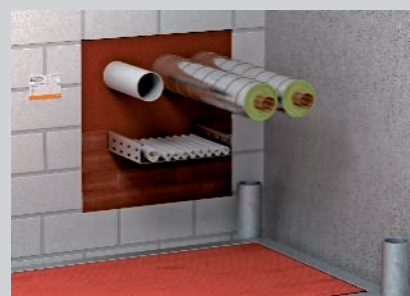

Combination insulation for various structures with labelling.



Application of the fire protection foam directly under the wall.



Labelled underfloor insulation with reserve empty pipe.



Empty pipes with tension wires can be foamed in for assignment at a later date.

Classification to EN

EI15

EI30

EI45

EI60

EI90

EI120



Erectors of combination insulation systems have to be trained.

PYROSIT® NG fire protection foam

Registration data

Combination insulation in walls/ceilings







Fire resistance class	EI 15, EI 30, EI 45, EI 60, EI 90, EI 120
Proof of application	European Technical Assessment of OIB, Vienna
Approval number	ETA-11/0527
Testing standard	EN 1366-3

Additive proofs

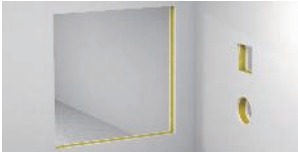
Heat permeation	Fraunhofer IBP Stuttgart, P1-002/2012
Air permeation/pressure resistance	ift Rosenheim, 11-003694-PR03
Noise insulation	HfT Stuttgart, 122-007-04P-186a

Areas of installation

Insulation systems in walls/ceilings

Component		Rigid walls	Flexible walls	Rigid floors
				
Min. component strength		10 cm	10 cm	15 cm
Min. insulation thickness		14.4 cm (EI90 / EI150) 20 cm (EI90 / EI150)	14.4 cm (EI90 / EI150) 20 cm (EI90 / EI150)	14.4 cm (EI90 / EI150) 20 cm (EI90 / EI150)
Opening size for 14.4 cm insulation thickness		↔ ≤ 45 cm ↕ ≤ 50 cm	↔ ≤ 45 cm ↕ ≤ 50 cm	↔ ≤ 45 cm ↕ ≤ 45 cm
Opening size for 20 cm insulation thickness		↔ ≤ 45 cm ↕ ≤ 50 cm	↔ ≤ 45 cm ↕ ≤ 50 cm	↔ ≤ 45 cm ↕ ≤ 45 cm

PYROSIT® NG fire protection foam Installations

Cable



Pipe bundle of electrical installation pipes



Cable bundle



Electrical installation pipe made of steel



Individual lines for control purposes



Cable support systems



Electrical installation pipe made of plastic, rigid



Metal pipes with path insulation

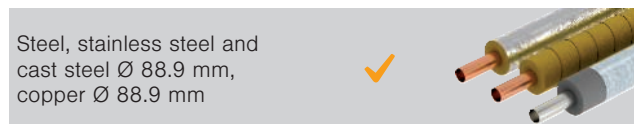

Electrical installation pipe made of plastic, flexible



Plastic pipes



Special installations

Cables

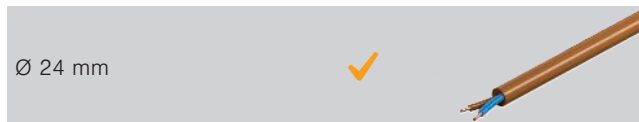

Open underfloor ducts



Screed-covered underfloor ducts



Klimasplit

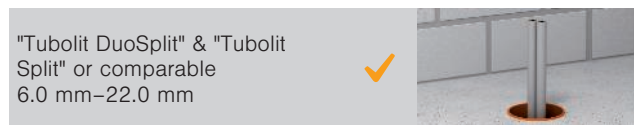

 Details on the version can be found in the proof of suitability or mounting instructions. All the stated dimensions are maximum values.

PYROPLUG® MagicBox 4-sided variant

System description

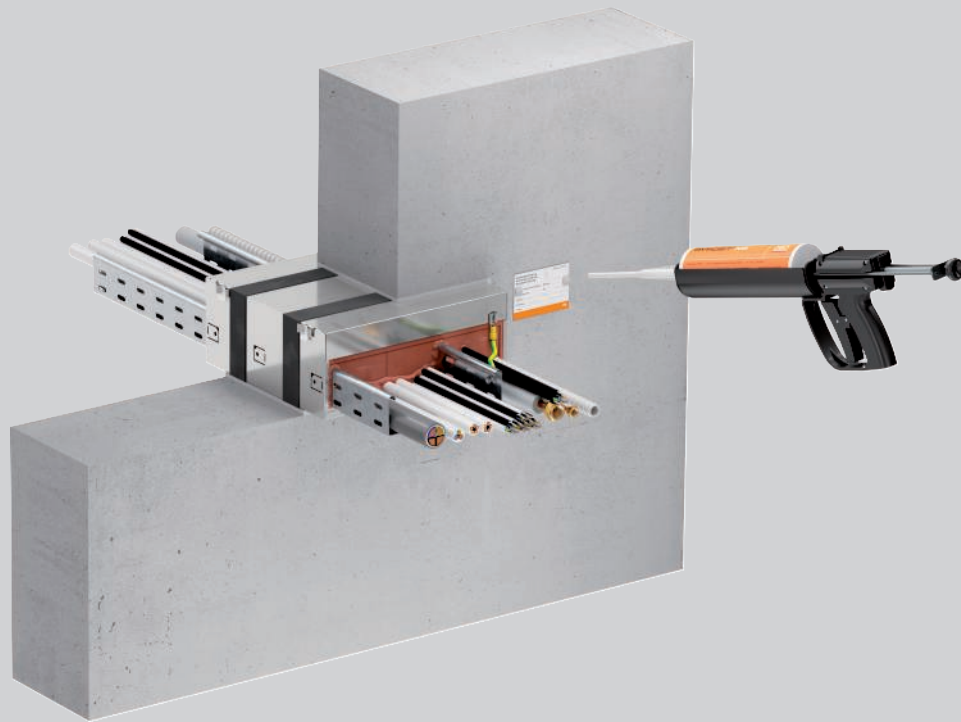

The OBO fire protection box PYROPLUG® MagicBox in the 4-sided variant consists of a two-part stainless steel housing with intumescent fire protection inlays. It can be used as an insulation system in walls and ceilings. Its releasable Magic connection means it's very quick to mount. Simply click the halves of the housing together, insert them in the component opening and mortar them in. Side straps secure the correct position of the PYROPLUG. MagicBox, allowing safe mortaring. The interior of the MagicBoxes can be fully assigned with installations. In addition, they are particularly suited to the creation of cable support systems with widths of up to 600 mm. Residual openings can be closed with the PYROSIT®NG fire protection foam which means that also seals with

difficult geometries can be filled in easily. Inlay blocks of forgiving foam can be used for larger cavities or for use as reserve insulation. The graphite strips contained in the scope of delivery are attached to the MagicBox at the width of the component. If there is a fire, these foam up, reliably closing the resulting gap around the MagicBox. The perfectly matched portfolio of different heights and widths can cover any application and also offers fire protection boxes with a particularly large interior. They can be arranged in groups with two boxes on top of each other or two boxes next to each other. The PYROPLUG® MagicBox is a construction product with CE labelling and has the fire resistance class EI90 (fire-resistant).

PYROPLUG® MagicBox 4-sided variant

Installation principle



Clicking the box together



Measuring the wall thickness and attaching graphite strips at the appropriate distance



Inserting the box into the wall opening

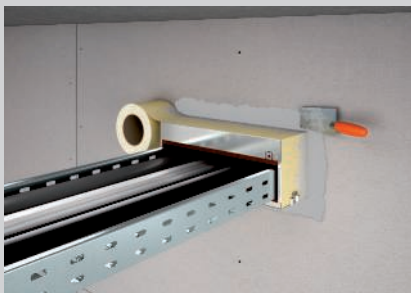

Masking and tidy mortaring in of the box

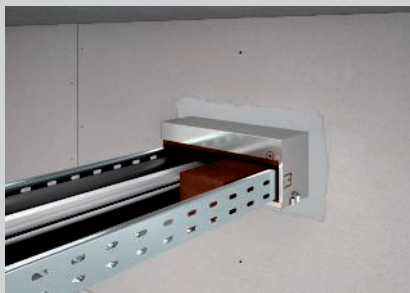

Inserting cut-to-size inlay block into the larger empty spaces

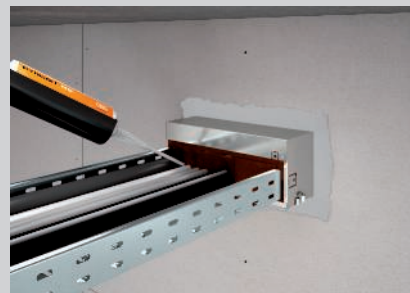

Closing the gaps completely with PYROSIT® NG fire protection foam

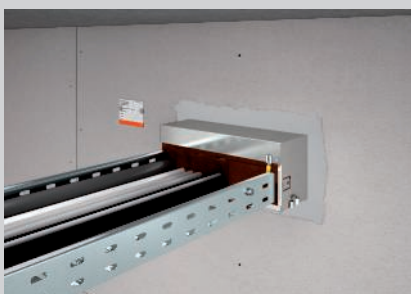

Attaching the equipotential bonding and the identification plate



Creation of groups with two boxes above each other or two boxes next to each other possible



Variant as ceiling insulation, fastening using fold-out lugs

Classification to EN

E190 **E120**



Erectors of combination insulation systems have to be trained.

PYROPLUG® MagicBox 3-sided variant

System description



In the 3-sided variant, the PYROPLUG® MagicBox consists of a single-part stainless steel housing with intumescent fire protection inlays. This variant can be used as an insulation system in walls, on raw floors, beneath system floors and as insulation for rising sections in ceilings. The stainless steel housing offers very quick mounting. Simply insert in the component opening and mortar in. Side straps secure the correct position of the PYROPLUG® MagicBox, allowing safe mortaring. The interior of the MagicBoxes can be fully assigned with installations. In addition, they are particularly suited to the creation of cable support systems with widths of up to 600 mm. Residual openings can be closed with the PYROSIT®NG fire protection foam which means that also seals with difficult

geometries can be filled in easily. Inlay blocks of forgiving foam can be used for larger cavities or for use as reserve insulation. The graphite strips contained in the scope of delivery are attached to the MagicBox at the width of the component. If there is a fire, these foam up, reliably closing the resulting gap around the MagicBox. The perfectly matched portfolio of different heights and widths can cover any application and also offers fire protection boxes with a particularly large interior. They can be arranged in groups with two boxes on top of each other or two boxes next to each other. The PYROPLUG® MagicBox is a construction product with CE labelling and has the fire resistance class EI90 (fire-resistant).

PYROPLUG® MagicBox 3-sided variant

Installation principle



Measuring the wall thickness and attaching graphite strips at the appropriate distance



Inserting the box into the wall opening and fastening to the floor

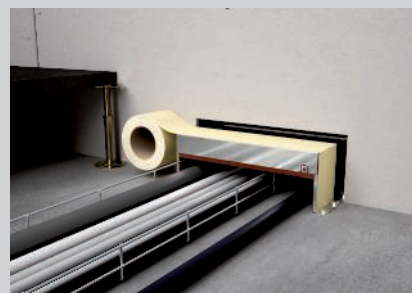

Masking of the box



Tidy mortaring in of the box



Inserting cut-to-size inlay block into the larger empty spaces



Closing the gaps completely with PYROSIT® NG fire protection foam



Attaching the equipotential bonding and the identification plate

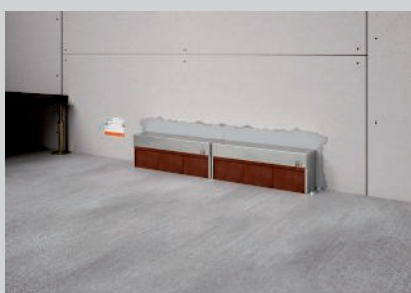

Creation of group with two boxes next to each other possible



Variant as ceiling insulation via rising sections

Classification to EN

E190 **E120**



Erectors of combination insulation systems have to be trained.

Insulation systems in walls/ceilings





Fire resistance class	Fire-resistant (90 minutes)
European Technical Assessment	ETA-22/0175
General type approval	Z-19.53-26
Test standard	DIN EN 1366-3
Classification standard	DIN EN 13501-2
Declaration of performance	05-DOP-14

Note:

For the legally compliant documentation, the European Technical Assessment (ETA), the general design approval (aBG) and the declaration of performance (DoP) are needed. The labelling of the insulation system and the submittal of the declaration of conformity statement are mandatory after the installation. All certificates and a sample of the declaration of conformity statement that can be edited are available from the download area at www.obo.de.

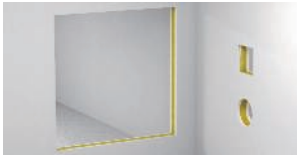
Areas of installation

Insulation systems in walls/ceilings

Component	Rigid walls	Flexible walls	Rigid floors
			
Min. component strength 	≥ 100 mm	≥ 100 mm	≥ 150 mm
Insulation thickness* 	300 mm	300 mm	300 mm

* According to box length

PYROPLUG® MagicBox Installations

Cable



Pipe bundle of electrical installation pipes



Cable bundle



Electrical installation pipe made of steel



Electrical installation pipe made of plastic, rigid



Cable support systems



Special installations

Hollow shaft conductor

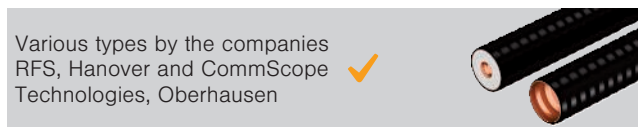

Climate splitting lines

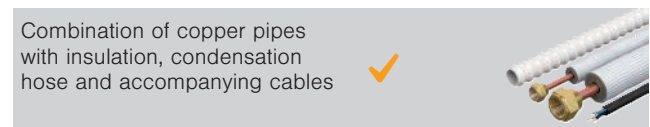

Copper pipes Polyurethane

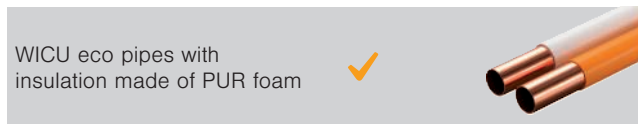

Hydraulic hoses

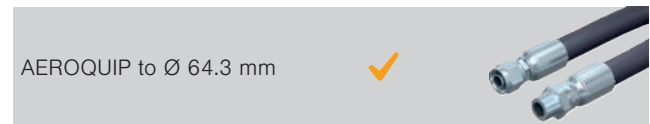

Details on the version can be found in the proof of suitability or mounting instructions.
All the stated dimensions are maximum values.

PYROPLUG® Block System description

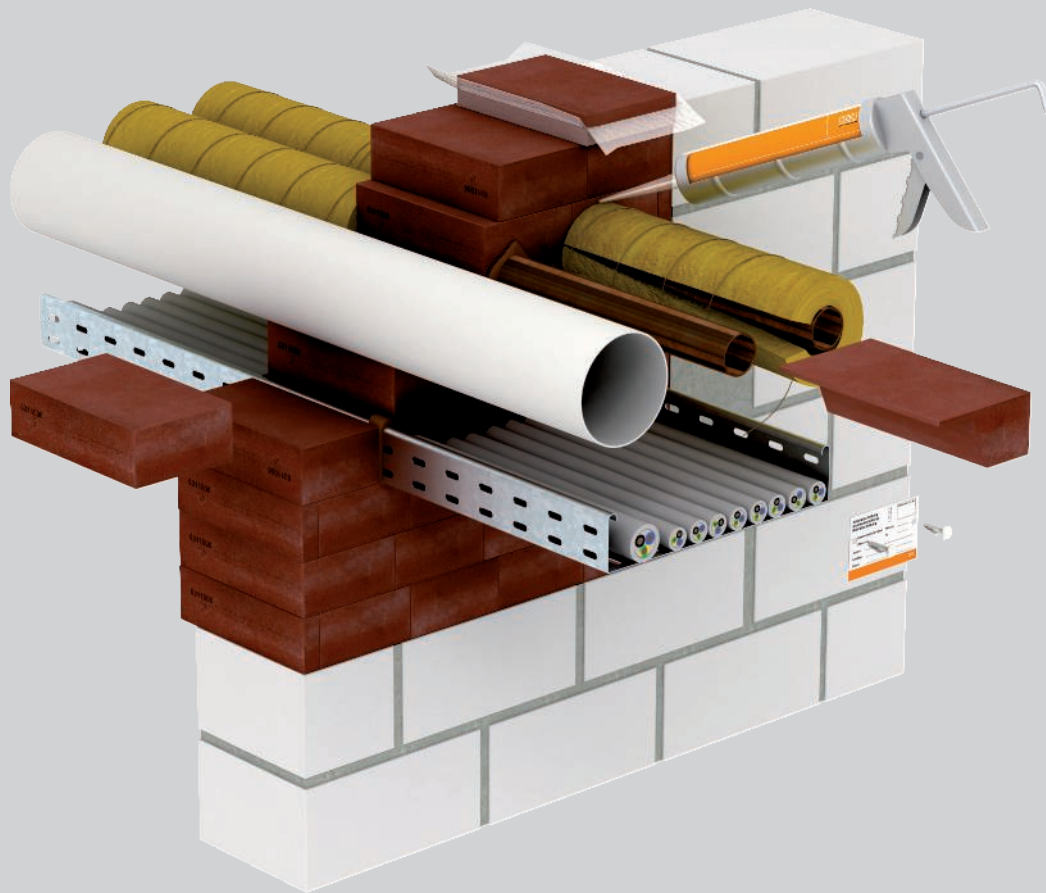

The OBO PYROPLUG® Block combination insulation is created from foam blocks, which, if there is a fire, expand without any noticeable pressure creation. In so doing, they form an insulating carbon foam. This reliably prevents the penetration of fire and smoke through the cable insulation. Combustible pipes can be run in this

insulation without an additional sleeve. Copper and steel pipes can be insulated either with or without section insulation. All the PYROPLUG® Block insulation is completely dust and fibre-free. This also applies to any installations at a later date. This is an aspect which is particularly important for installation in IT and laboratory rooms.

PYROPLUG® Block

Installation principle



Mounting of the cut blocks.



Vacuum blocks for simple residual gap closing.



Simple reinstallation through removal of individual blocks.



Running of combustible pipes without additional measures.



Run-through, non-combustible pipes with section insulation.



Tight-fitting installation of the blocks in the ceiling penetration.



Cut thin strips for the duct compartments.

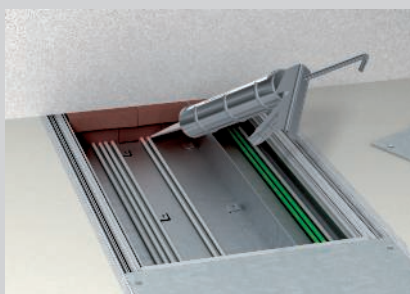

Close the joints and spandrels between the installed cables and the blocks with a layer of the FBA-SP fire protection compound of at least 2 cm deep.



Close the residual joints between cables and blocks with the FBA-SP filler.

Classification to EN

S30

S60

S90

Classification to EN

EI15

EI30

EI45

EI60

EI90

EI120



Erectors of combination insulation systems have to be trained.

Combination insulation in walls/ceilings







Fire resistance class	EI 15, EI 30, EI 45, EI 60, EI 90, EI 120
Proof of application	European Technical Assessment of OIB, Vienna
Approval number	ETA-15/0803
Testing standard	EN 1366-3

Additive proofs

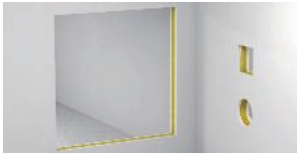
Heat permeation	Fraunhofer IBP Stuttgart, P1-001/2012
Air permeation/pressure resistance	ift Rosenheim, 11-003694-PR02
Noise insulation	HfT Stuttgart, 122-007-04P-186a

Areas of installation

Insulation systems in walls/ceilings

Component	Rigid walls	Flexible walls	Rigid floors
			
Min. component strength 	10 cm (EI 30 / EI 60 / EI 90 / EI 120)	10 cm (EI 30 / EI 60 / EI 90 / EI 120)	15 cm (EI 30 / EI 60 / EI 90 / EI 120)
Min. insulation thickness 	14.4 cm (EI 30 / EI 60) 20 cm (EI 90 / EI 120)	14.4 cm (EI 30 / EI 60) 20 cm (EI 90 / EI 120)	14.4 cm (EI 30 / EI 60) 20 cm (EI 90 / EI 120)
Opening size for 14.4 cm insulation thickness 	↔ ≤ 100 cm ↕ ≤ 60 cm	↔ ≤ 100 cm ↕ ≤ 60 cm	↔ ≤ 37.5 cm ↕ Unlimited ↔ ≤ 40 cm ↕ ≤ 60 cm
	↔ ≤ 60 cm ↕ ≤ 100 cm	↔ ≤ 60 cm ↕ ≤ 100 cm	↔ ≤ 100 cm ↕ ≤ 60 cm ↔ ≤ 45 cm ↕ ≤ 225 cm
Opening size for 20 cm insulation thickness 	↔ ≤ 100 cm ↕ ≤ 60 cm	↔ ≤ 100 cm ↕ ≤ 60 cm	↔ ≤ 37.5 cm ↕ Unlimited ↔ ≤ 40 cm ↕ Unlimited
	↔ ≤ 60 cm ↕ ≤ 100 cm	↔ ≤ 60 cm ↕ ≤ 100 cm	↔ ≤ 60 cm ↕ ≤ 130 cm ↔ ≤ 70 cm ↕ ≤ 100 cm

PYROPLUG® Block Installations

Cable



Pipe bundle of electrical installation pipes



Cable bundle



Electrical installation pipe made of steel



Individual lines for control purposes



Cable support systems



Electrical installation pipe made of plastic, rigid



Metal pipes with path insulation



Electrical installation pipe made of plastic, flexible



Plastic pipes



Special installations

Cables



Details on the version can be found in the proof of suitability or mounting instructions. All the stated dimensions are maximum values.

PYROPLUG® Peg foam series

System description

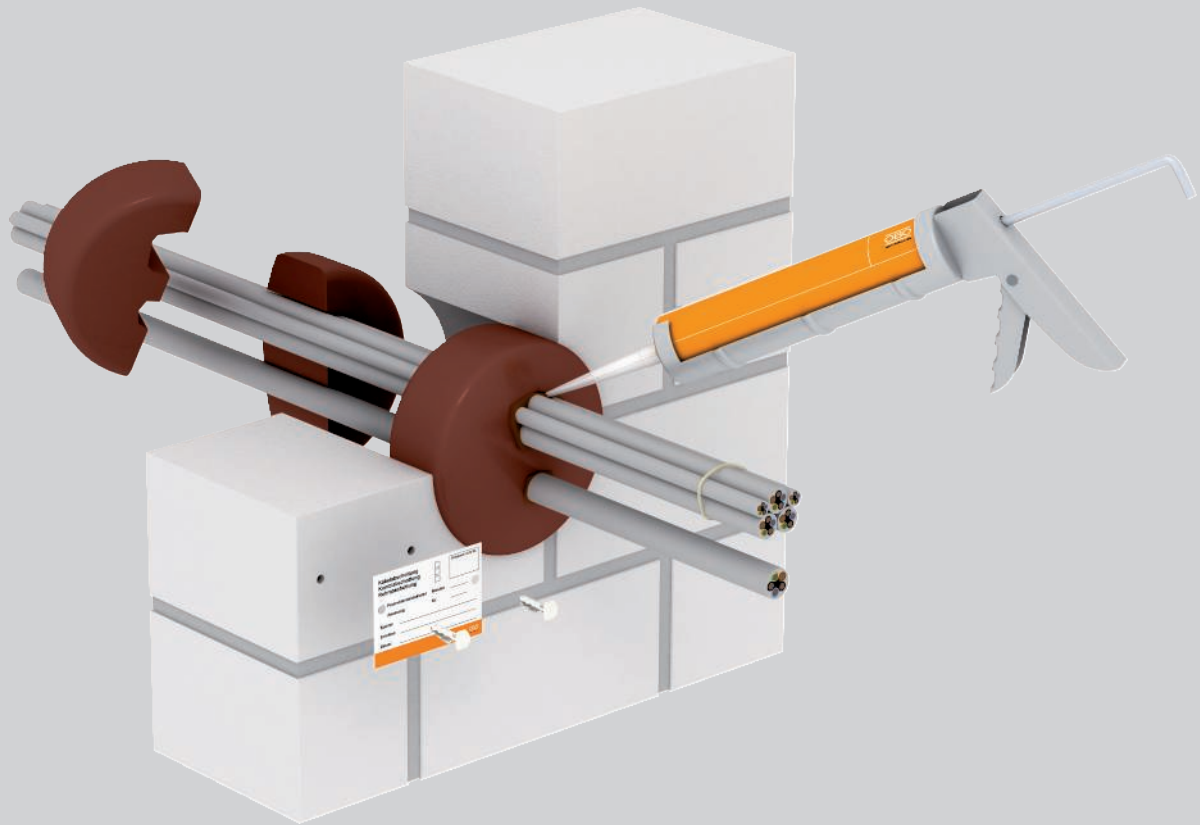

The PYROPLUG® Peg system from OBO is used to create cable insulation with fire protection foam plugs. The foam plugs are ideal for closing core drill holes in solid walls and concrete ceilings. The foam plugs are made of permanently elastic, closed-pore foam, which expands in the event of fire without any significant pressure build-up, thus creating an insulating plastic foam. This reliably

prevents the penetration of fire and smoke through the cable insulation. The PYROPLUG® Peg insulation system can be used without difficulty in areas of data processing and in laboratories, as mounting is completely clean and is free of dust and fibres. This also applies to any necessary cable installations at a later date. Special tools are not required for processing, a knife is sufficient.

PYROPLUG® Peg foam series

Installation principle



Ideal for core drill holes of 55 mm to 240 mm.



Cutting of the plugs for cable assignment on the edge of the core hole.

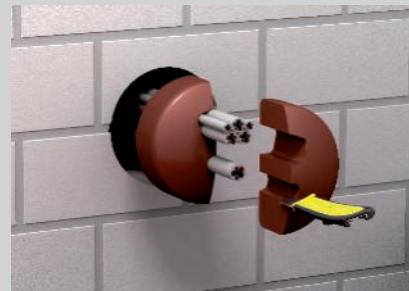

Push cut plugs into the core hole.



Due to the elastically material a quick mounting is possible.



Cutting and mounting of the plugs in ceilings.



Residual joints are closed off with the filler FBA-SP.



Small distance to next core drill hole possible.

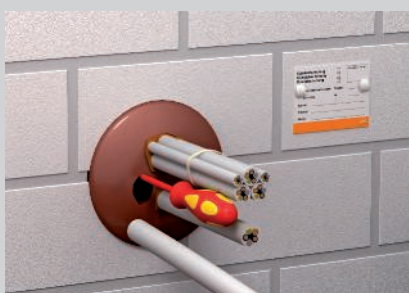

With retroinstallations, carefully cut or drill the plugs.

Classification to EN

S30

S60

S90

Classification to EN

EI15

EI30

EI45

EI60

EI90

EI120



Erectors of combination insulation systems have to be trained.

PYROPLUG® Peg foam series

Registration data

Combination insulation in walls/ceilings

Fire resistance class	EI 30, EI 45, EI 60, EI 90, EI 120
Proof of application	European Technical Assessment of OIB, Vienna
Approval number	ETA-15/0701
Testing standard	EN 1366-3

Additive proofs (acc. to ETA)

Heat permeation	see section 3.5 from ETA-15/0701
Air permeation/pressure resistance	see section 3.2 from ETA-15/0701
Air noise insulation	see section 3.4 from ETA-15/0701

Areas of installation

Insulation systems in walls/ceilings

Component REI30

Rigid walls



Flexible walls

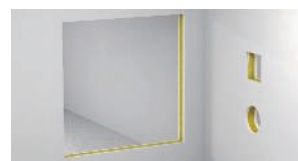

Rigid floors



Min. component strength



10 cm (EI 30 / EI 60 / EI 90)
20 cm (EI 90 / EI 120)

10 cm (EI 30 / EI 60 / EI 90)
20 cm (EI 90 / EI 120)

15 cm (EI 30 / EI 60 / EI 90)
20 cm (EI 90 / EI 120)

Min. insulation thickness



>17 cm–<20 cm (EI 30 / EI 60 / EI 90)
20 cm (EI 90 / EI 120)

>17 cm–<20 cm (EI 30 / EI 60 / EI 90)
20 cm (EI 90 / EI 120)

>17 cm–<20 cm (EI 30 / EI 60 / EI 90)
20 cm (EI 90 / EI 120)

Opening size



Ø 55 mm, Ø 68 mm,
Ø 97 mm, Ø 112 mm,
Ø 124 mm, Ø 155 mm,
Ø 190 mm, Ø 240 mm

Ø 55 mm, Ø 68 mm,
Ø 97 mm, Ø 112 mm,
Ø 124 mm, Ø 155 mm,
Ø 190 mm, Ø 240 mm

Ø 55 mm, Ø 68 mm,
Ø 97 mm, Ø 112 mm,
Ø 124 mm, Ø 155 mm,
Ø 190 mm, Ø 240 mm

PYROPLUG® Peg foam series Installations

Cable



Pipe bundle of electrical installation pipes



Cable bundle



Electrical installation pipe made of steel



Individual lines for control purposes



Cable support systems



Electrical installation pipe made of plastic, rigid



Metal pipes with path insulation



Electrical installation pipe made of plastic, flexible



Plastic pipes



Special installations

Cables

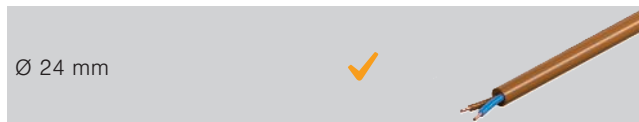

Insulation in the lining pipe



Details on the version can be found in the proof of suitability or mounting instructions.
All the stated dimensions are maximum values.

PYROPLUG® Box box insulation System description



The PYROPLUG® Box system from OBO is used to create cable insulation with boxes made of foam. The system is particularly suitable for simple mounting of cable insulation in light-duty partitions. No layering is required. Installation in solid walls and solid ceilings is also possible and approved. The insulation system consists of a two-part frame and two matching internal pieces. The permanently

elastic, closed-pore foam material expands in the event of fire without any significant pressure build-up, thus creating an insulating plastic foam. This reliably prevents the penetration of fire and smoke through the cable insulation. The usable area of the boxes corresponds to the maximum approval cable assignment area of 60%. It is thus impossible to over assign it with cables.

PYROPLUG® Box box insulation

Installation principle



Insertion of the split frame in light-duty partitions, without additional layering.



Mounting of the frame with previously installed cables.



Exact cutting of the internal pieces and then insertion in the frame.



Closing joint component on full assignment with FBA-SP filler.



Grouped arrangement of the boxes.

Classification to EN

S30

S60

S90



Erectors of combination insulation systems have to be trained.

PYROPLUG® Box box insulation

Registration data





Insulation in wall/ceiling

Fire resistance class	fire-resistant (90 minutes)
General type approval	Z-19.53-2473
General construction approval	Z-19.15-2390
Testing standard	DIN 4102 Part 9



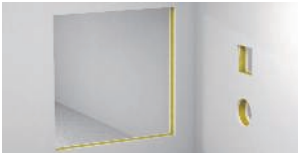



Areas of installation

Insulation systems in walls/ceilings

Component REI30

	Rigid walls	Flexible walls	Rigid floors
			
Min. component strength 	5 cm	7.5 cm (S30 / S60 / S90)	15 cm
Min. insulation thickness 	20 cm (S30 / S60 / S90)	20 cm (S30 / S60 / S90)	20 cm (S30 / S60 / S90)
Opening size 	↔ ≤ 50 cm ↕ ≤ 50 cm	↔ ≤ 50 cm ↕ ≤ 50 cm	↔ ≤ 50 cm ↕ ≤ 50 cm

Component REI90

	Rigid walls	Flexible walls	Rigid floors
			
Min. component strength 	10 cm	10 cm	15 cm
Min. insulation thickness 	20 cm (S30 / S60 / S90)	20 cm (S30 / S60 / S90)	20 cm (S30 / S60 / S90)
Opening size 	↔ ≤ 50 cm ↕ ≤ 50 cm	↔ ≤ 50 cm ↕ ≤ 50 cm	↔ ≤ 50 cm ↕ ≤ 50 cm

PYROPLUG® Box box insulation Installations

Cable



Pipe bundle of electrical installation pipes



Cable bundle



Electrical installation pipe made of steel



Individual lines for control purposes



Cable support systems



Electrical installation pipe made of plastic, rigid



Metal pipes with path insulation



Electrical installation pipe made of plastic, flexible



Plastic pipes



 Details on the version can be found in the proof of suitability or mounting instructions. All the stated dimensions are maximum values.

PYROPLUG® Shell pipe shells

System description

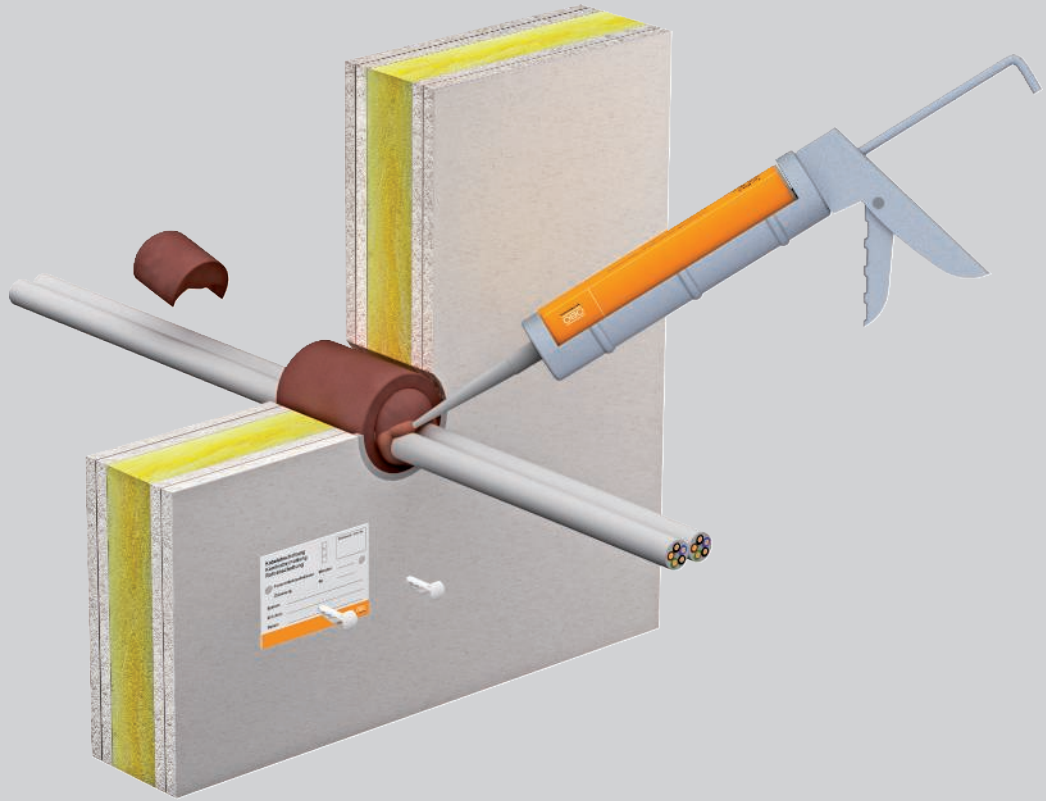

The OBO PYROPLUG® Shell system is specially designed for cable insulation in box drill holes in light-duty partitions. The insulation system consists of a pipe shell and two matching plugs. The material is made of permanently elastic, closed-pore foam, which expands in the event of fire without any significant pressure build-up, thus

creating an insulating plastic foam. This reliably prevents the penetration of fire and smoke through the cable insulation. The ratio of the external diameter to the internal diameter of the pipe shell ensures that over assignment with cables is not possible, even at full assignment.

PYROPLUG® Shell pipe shells

Installation principle



Drilling of a hole with a drill crown.



Grouped arrangement of the drill holes.

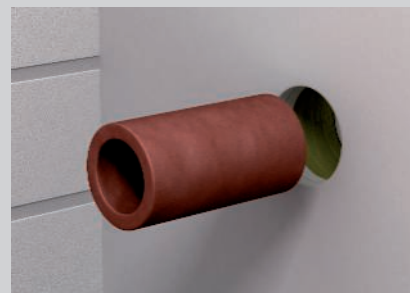

Insertion of the pipe shell in the light-duty partition.



For previously installed cables, cutting of the pipe shell.



Cutting and insertion of the plugs in the pipe shell.



Full assignment of the pipe shell.

Classification to EN

S30

S60

S90



Erectors of combination insulation systems have to be trained.

PYROPLUG® Shell pipe shells

Registration data





Insulation in wall/ceiling

Fire resistance class	fire-resistant (90 minutes)
General type approval	Z-19.53-2475
General construction approval	Z-19.15-2390
Testing standard	DIN 4102 Part 9



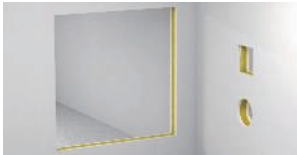



Areas of installation

Insulation systems in walls/ceilings

Component REI30

	Rigid walls	Flexible walls	Rigid floors
			
Min. component strength 	5 cm	7.5 cm (S30 / S60 / S90)	15 cm
Min. insulation thickness 	10 cm (S30 / S60 / S90)	10 cm (S30 / S60 / S90)	10 cm (S30 / S60 / S90)
Opening size 	≤ Ø 10 cm	≤ Ø 10 cm	≤ Ø 10 cm

Component REI90

	Rigid walls	Flexible walls	Rigid floors
			
Min. component strength 	10 cm	10 cm	15 cm
Min. insulation thickness 	10 cm (S30 / S60 / S90)	10 cm (S30 / S60 / S90)	10 cm (S30 / S60 / S90)
Opening size 	≤ Ø 10 cm	≤ Ø 10 cm	≤ Ø 10 cm

PYROPLUG® Shell pipe shells Installations

Cable



Pipe bundle of electrical installation pipes



Cable bundle



Electrical installation pipe made of steel



Individual lines for control purposes



Cable support systems



Electrical installation pipe made of plastic, rigid



Metal pipes with path insulation



Electrical installation pipe made of plastic, flexible



Plastic pipes



Details on the version can be found in the proof of suitability or mounting instructions. All the stated dimensions are maximum values.

PYROPLUG® Mini filler

System description

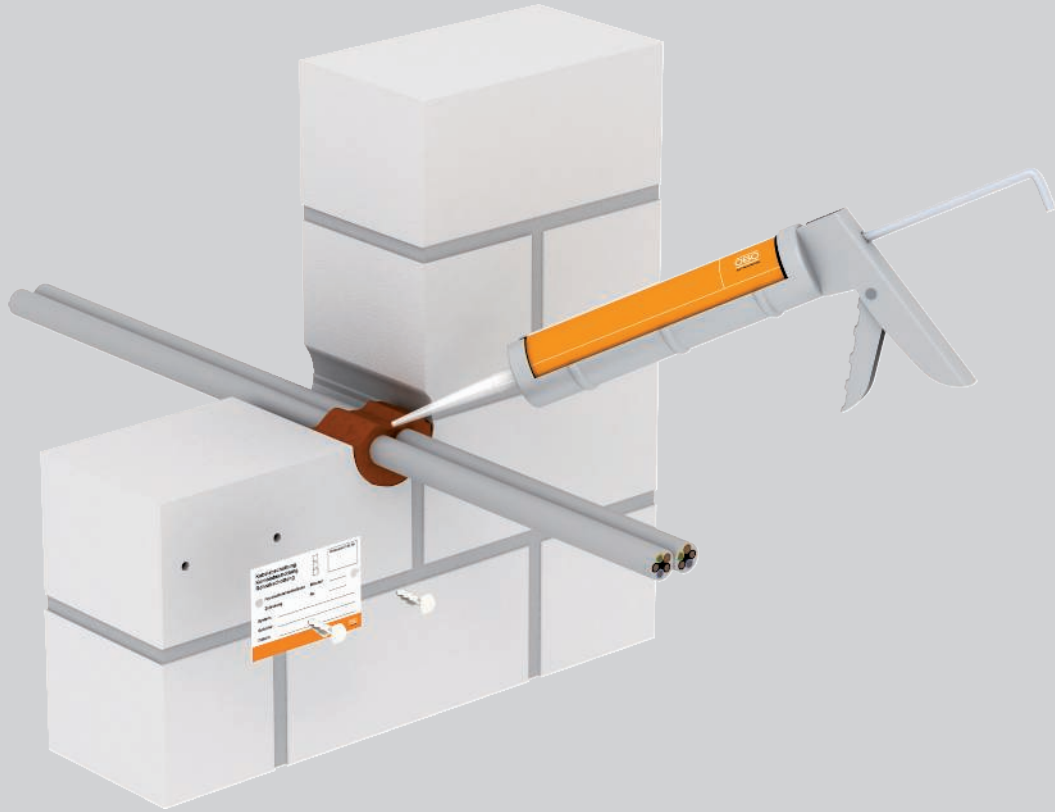

The OBO PYROPLUG® Mini system is ideal for small, round cable insulations up to a diameter of 8 cm. It only consists of the one-component filler PYROPLUG® Screed. In light-duty partitions, the

empty mini pipe shell of the PYROPLUG® Shell system is used as layering. The interior of these pipe shells may be completely assigned. Only the residual joints must be filled with the filler.

PYROPLUG® Mini filler

Installation principle



Closing of the opening with the filler FBA-SP.



In light-duty partitions, use of the mini pipe shell FBA-DR.



Complete assignment of the mini pipe shell.

Classification to EN

S30

S60

S90



Erectors of combination insulation systems have to be trained.

PYROPLUG® Mini filler

Registration data

Insulation in wall/ceiling

Fire resistance class	fire-resistant (90 minutes)
General construction approval	Z-19.53-2622
European Technical Assessment	ETA-15/0803
Testing standard	EN 1366-3

Areas of installation

Insulation systems in walls/ceilings

Component F90

Rigid walls



Flexible walls

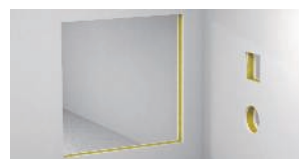

Rigid floors



Min. component strength



10 cm
(S30 / S60 / S90)

10 cm
(S30 / S60 / S90)

15 cm
(S30 / S60 / S90)

Min. insulation thickness



10 cm
(S30 / S60 / S90)

10 cm
(S30 / S60 / S90)

15 cm
(S30 / S60 / S90)

Opening size



≤ Ø 8 cm

≤ Ø 8 cm

≤ Ø 8 cm

PYROPLUG® Mini filler

Installations

Cable



Pipe bundle of electrical installation pipes



Cable bundle



Electrical installation pipe made of steel



Individual lines for control purposes



Cable support systems



Electrical installation pipe made of plastic, rigid



Metal pipes with path insulation



Electrical installation pipe made of plastic, flexible



Plastic pipes



 Details on the version can be found in the proof of suitability or mounting instructions. All the stated dimensions are maximum values.

MMS-plus MS mounting rail tie, with flat panhead

St G

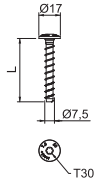

Type	Dimen- sion mm	Dim. L mm	Drill hole		Screw system	Pack Piece	Weight kg/100 pc.	Item no.
			Ø	Head Ø				
MMS+ MS 7.5x50	7,5x50	50	6	17	Torx	100	1.500	3498261

Bolt tie for direct mounting without additional anchors in cracked and uncracked concrete and masonry. With large round head to fasten mounting and profile rails. Torx drive T30.
Construction product tested according to EAD and CE mark, with European Technical Assessment (ETA) and proof of suitability. Load-bearing capacities under fire loads proven up to fire resistance class R120.





PYROCOMB® Tubes pipe sleeve System description



The PYROCOMB® Tubes system is used to create cable insulation with pipe sleeves. The system comprises multiple sizes of the pipe sleeve, type TCX. This allows simple insulation of bundles of plastic electrical installation pipes, rigid or flexible, up to a size of M63. It is irrelevant whether the

pipes are filled with cables or are empty. In the event of fire, the fire protection material inserted within the seal foams up after a few minutes under high pressure, closing the softened bundles at a high pressure. This safely prevents the spread of fire and smoke, should a fire occur.

PYROCOMB® Tubes pipe sleeve

Installation principle



Two-sided arrangement of the pipe sleeves for wall mounting.



Mounting on the underside of the ceiling with metal anchors.



Closing of the ring gap with the insulation layer creator DSX.

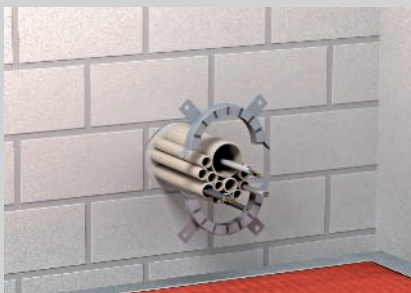

Combination of the sleeve halves and fastening on the wall.

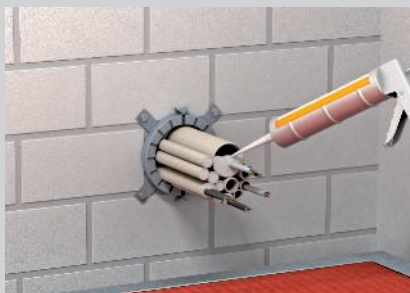

Closing of the pipe ends with the insulation layer creator DSX.

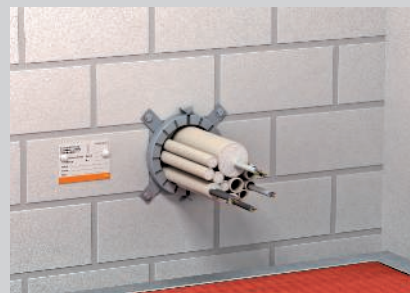

Labelled insulation of installation pipe bundles.

Classification to EN

S30

S60

S90

Classification to EN

EI15

EI30

EI45

EI60

EI90

EI120



Erectors of combination insulation systems have to be trained.

PYROCOMB® Tubes pipe sleeve







Registration data

Combination insulation in walls and ceilings

Fire resistance class	EI 15, EI 30, EI 45, EI 60, EI 90, EI 120
Proof of application	General construction approval of OIB, Vienna
Approval number	ETA-12/0207
Testing standard	EN 1366-3

Areas of installation

Insulation systems in walls/ceilings

Component		Rigid walls	Flexible walls	Rigid floors
				
Min. component strength		10 cm (EI 30 / EI 60 / EI 90 / EI 120)	10 cm (EI 30 / EI 60 / EI 90 / EI 120)	15 cm (EI 30 / EI 60 / EI 90 / EI 120)
Min. insulation thickness		10 cm (EI 60 / EI 90 / EI 120)	10 cm (EI 60 / EI 90 / EI 120)	15 cm (EI 60 / EI 90 / EI 120)
Opening size		Ø 32 mm, Ø 40 mm, Ø 50 mm, Ø 63 mm, Ø 75 mm, Ø 90 mm, Ø 110 mm, Ø 125 mm	Ø 32 mm, Ø 40 mm, Ø 50 mm, Ø 63 mm, Ø 75 mm, Ø 90 mm, Ø 110 mm, Ø 125 mm	Ø 32 mm, Ø 40 mm, Ø 50 mm, Ø 63 mm, Ø 75 mm, Ø 90 mm, Ø 110 mm, Ø 125 mm

PYROCOMB® Tubes pipe sleeve Installations

Cable



Pipe bundle of electrical installation pipes



Cable bundle



Electrical installation pipe made of steel



Individual lines for control purposes



Cable support systems



Electrical installation pipe made of plastic, rigid

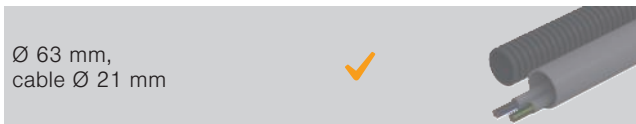

Metal pipes with path insulation



Electrical installation pipe made of plastic, flexible



Plastic pipes



Details on the version can be found in the proof of suitability or mounting instructions. All the stated dimensions are maximum values.

Threaded rod

St G



Type	Thread	Dim.	Dim.	Pack	Weight	Item no.
		d	L			
TR M8 1M G	M8	8	1000	10	30.000	3141128

Threaded rod to DIN 976.

MMS-plus P round head tie, with panhead

St G

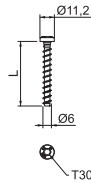
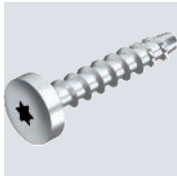

Type	Dimen- sion	Dim. L	Drill		Screw	Pack	Weight	Item no.
			hole	Head Ø				
MMS+ P 6x35	6x35	35	5	11.2	Torx	100	0.710	3498103
MMS+ P 6x50	6x50	50	5	11.2	Torx	100	1.000	3498108

Bolt tie for direct mounting without additional anchors in cracked and uncracked concrete and masonry. With round head for universal fastenings. Torx drive T30.
Construction product tested according to EAD and CE mark, with European Technical Assessment (ETA) and proof of suitability. Load-bearing capacities under fire loads proven up to fire resistance class R120.

MMS-plus MS mounting rail tie, with flat panhead

St G

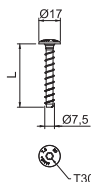

Type	Dimen- sion	Dim. L	Drill		Screw	Pack	Weight	Item no.
			hole	Head Ø				
MMS+ MS 7.5x50	7,5x50	50	6	17	Torx	100	1.500	3498261

Bolt tie for direct mounting without additional anchors in cracked and uncracked concrete and masonry. With large round head to fasten mounting and profile rails. Torx drive T30.
Construction product tested according to EAD and CE mark, with European Technical Assessment (ETA) and proof of suitability. Load-bearing capacities under fire loads proven up to fire resistance class R120.





PYROCOMB® Intube pipe shell System description



The PYROCOMB® Intube system is used to create cable insulation with pipe shells or half shells. The pipe shell is particularly suitable for core drill holes and can very easily be installed in solid ceilings or walls and also light-duty partitions. For this, two half pipe sleeves are clicked together and bedded in mortar in the core hole. Then the pipe sleeves are closed with seals and the surface is sealed with ASX ablation coating. The cables don't require any coating. The half shell can be used particularly well

in the underfloor area. It is sealed on one side with fire protection plugs and sealed with ASX ablation coating. In case of a fire, the inner coating of the pipe shell or the half shell expands and, in so doing, closes the opening cross-section completely. The transfer of fire and smoke is thus safely prevented. With the PYROCOMB® Intube system, 100% assignment of the interior is possible.

PYROCOMB® Intube pipe shell

Installation principle



Mounting of the pipe shell by clicking the half shells together around the existing installation.



Closing of the opening with PYROMIX® mortar.



Adjust the foam plugs to installations using a knife and create smoke gas-tight sealing of the sealings using the ASX coating compound.



With ceiling mounting, use a lined body to prevent the pipe shell from falling out.

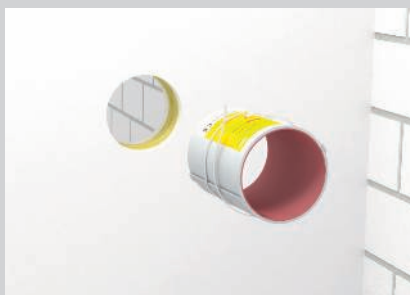

In certain applications, securing with metal tensioning straps in light-duty partitions is necessary.



Pipe shells with full assignment with cable bundles and electrical installation pipes.



Mounting of the half shell.



Adjusting the foam plug to the cables.



Fully installed half shell in PYROPLATE® Fibre soft insulation.

Classification to EN

- EI15
- EI30
- EI45
- EI60
- EI90



Erectors of combination insulation systems have to be trained.

PYROCOMB® Intube pipe shell

Registration data

Insulation in wall/ceiling







Fire resistance class	EI 60, EI 90, EI 120
Proof of application	General construction approval of OIB, Vienna
Approval number	ETA - 13/0904
Testing standard	EN 1366-3

Note:

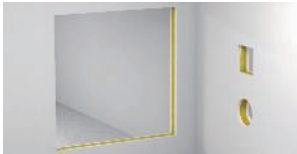
For the legally compliant documentation, the European Technical Assessment (ETA), the general design approval (aBG) and the declaration of performance (DoP) are needed. The labelling of the insulation system and the submittal of the declaration of conformity statement are mandatory after the installation. All certificates and a sample of the declaration of conformity statement that can be edited are available from the download area at www.obo.de.

Areas of installation

Insulation systems in walls/ceilings

Component		Rigid walls	Flexible walls	Rigid floors
				
Min. component strength		10 cm - 15 cm (EI 30 / EI 60 / EI 90) CTS-150	10 cm - 15 cm (EI 30 / EI 60 / EI 90) CTS-150	12.5 cm (EI 30 / EI 45 / EI 60) CTS-150
		15 cm - 30 cm (EI 30 / EI 60 / EI 90 / EI 120) CTS-300	10 cm - 15 cm (EI 30 / EI 60 / EI 90 / EI 120) CTS-300	15 cm (EI 30 / EI 60 / EI 90 / EI 120) CTS-300
Min. insulation thickness		10 cm - 15 cm (EI 30 / EI 60 / EI 90) CTS-150	10 cm - 15 cm (EI 30 / EI 60 / EI 90) CTS-150	12.5 cm (EI 30 / EI 45 / EI 60) CTS-150
		15 cm - 30 cm (EI 30 / EI 60 / EI 90 / EI 120) CTS-300	10 cm - 15 cm (EI 30 / EI 60 / EI 90 / EI 120) CTS-300	15 cm (EI 30 / EI 60 / EI 90 / EI 120) CTS-300
Opening size		Ø 125 mm	Ø 125 mm	Ø 125 mm
		55 mm x 116 mm	55 mm x 116 mm	55 mm x 116 mm



PYROCOMB® Intube pipe shell Installations

Cable



Pipe bundle of electrical installation pipes



Cable bundle



Electrical installation pipe made of steel



Individual lines for control purposes



Cable support systems



Electrical installation pipe made of plastic, rigid



Metal pipes with path insulation



Electrical installation pipe made of plastic, flexible



Plastic pipes



Details on the version can be found in the proof of suitability or mounting instructions. All the stated dimensions are maximum values.

PYROMIX Screed® small insulation System description

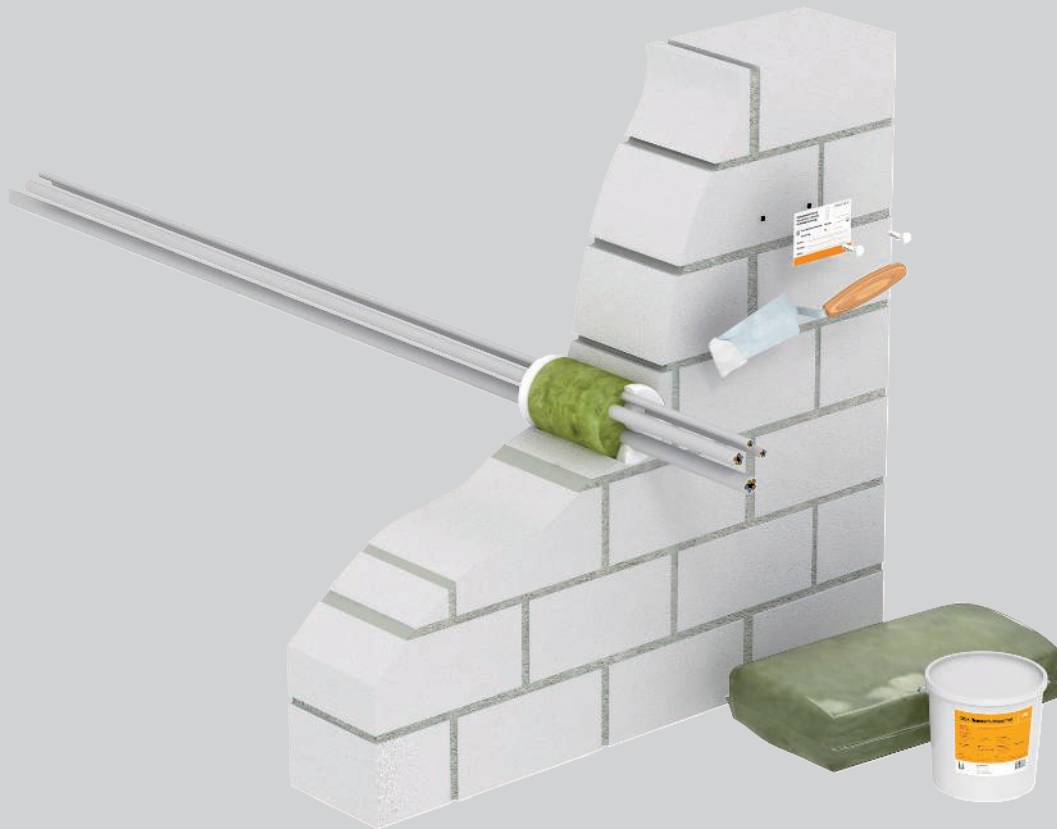

Small insulation for cables is created using the PYROMIX® Screed system. It consists of OBO's insulation forming material, type DSX, and the MIW mineral wool. As the insulation basis, the opening is first filled using the non-combustible mineral wool (melting point $\geq 1,000$ °C). Then, both sides

of the opening are sealed with the DSX insulation creator. If there is a fire, the filler foams up, preventing penetration by fire and smoke. When the material foams up, heat is also drawn from the cables, thus considerably reducing the transfer of heat via the copper cores.

PYROMIX Screed® small insulation

Installation principle



Mineral wool with melting point $\geq 1,000$ °C to plug the opening.



Closure of the surfaces on both sides with the DSX insulation layer creator. (Minimum thickness 1 cm on each side.)



Labelling of the small insulation.

Classification to EN



Erectors of combination insulation systems have to be trained.

PYROMIX Screed® small insulation





Registration data

Insulation in walls/ceilings

Fire resistance class	S30, S60, S90
Proof of application	General type approval of the DIBt, Berlin
Approval number	Z-19.53-2314
Testing standard	DIN 4102 Part 9

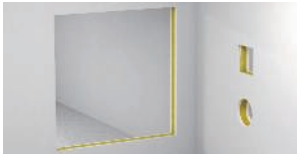
Areas of installation

Insulation systems in walls/ceilings

Component		Rigid walls	Flexible walls	Rigid floors
				
Min. component strength		10 cm (S30/S60/S90)	10 cm (S30/S60/S90)	15 cm
Min. insulation thickness		10/15 cm (S30/S60/S90)	10/15 cm (S30/S60/S90)	15 cm (S30 / S60 / S90)
Opening size		$\leftrightarrow \leq 35 \text{ cm}$ $\updownarrow \leq 15 \text{ cm}$ $\circ \leq \varnothing 15 \text{ cm}$	$\circ \leq 35 \text{ cm}$ $\leq 15 \text{ cm}$ $\leq \varnothing 15 \text{ cm}$	$\leftrightarrow \leq 15 \text{ cm}$ $\updownarrow \leq 15 \text{ cm}$ $\circ \leq \varnothing 15 \text{ cm}$

PYROMIX Screed® small insulation Installations

Cable



Pipe bundle of electrical installation pipes



Cable bundle



Electrical installation pipe made of steel



Individual lines for control purposes



Cable support systems



Electrical installation pipe made of plastic, rigid



Metal pipes with path insulation



Electrical installation pipe made of plastic, flexible



Plastic pipes



Details on the version can be found in the proof of suitability or mounting instructions. All the stated dimensions are maximum values.

Cable insulation Conlit® Bandage System description

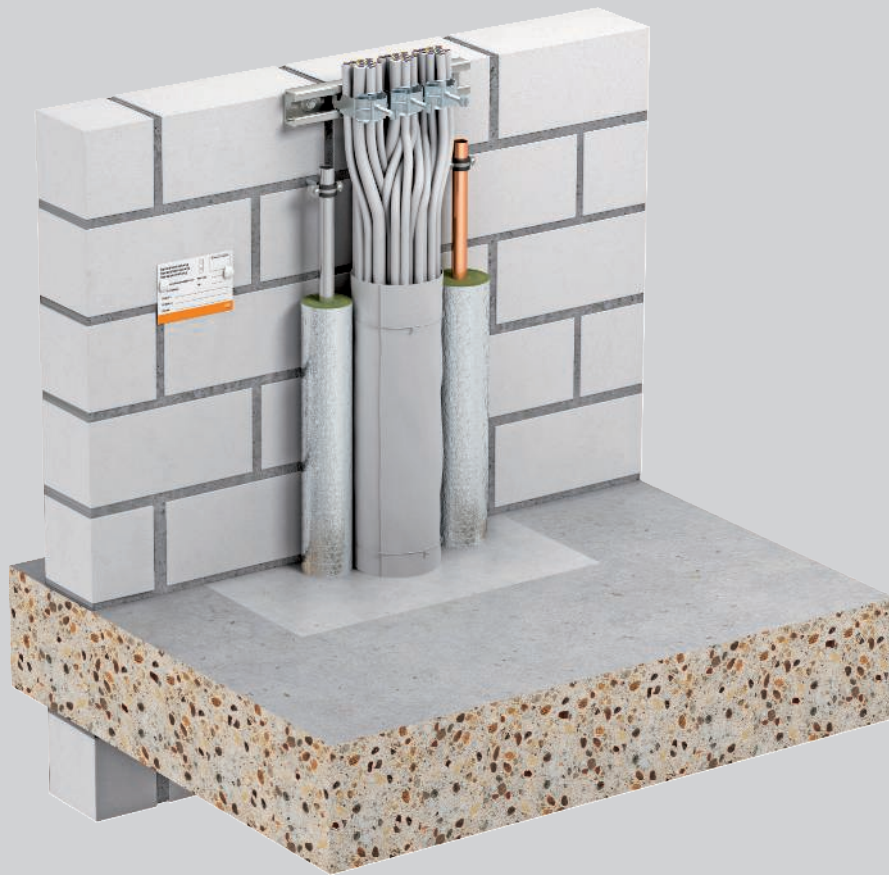

The Conlit® system, consisting of the fire protection bandage, type CL-KS, is used within buildings as cable insulation for individual cables, cable and electrical installation pipe bundles (EIP). The flexible bandage is simply laid around the installations and fixed with a wire. Cable bundles and rigid EIPs must be wound with at least two layers of the bandage and flexible EIPs with at

least three layers. In case of a fire, the material foams up and closes the opening cross-section. The fire protection bandage is suitable for cable and electrical installation pipe bundles up to 100 mm diameter. No spacing is required to many insulated pipes. The system insulates fire sections for a period of max. 90 minutes.

Cable insulation Conlit® Bandage

Installation principle



Preparation of the cable insulation.



Installation of the fire protection bandage.



Fixing of the bandage using winding wire.



Using mortar, close off the residual insulation opening and mount the identification plate.



Using mortar, close off the residual insulation opening and mount the identification plate.



Installation of the fire protection bandage with no distance to the Rockwool Conlit pipe insulation.

Classification to EN

S30

S60

S90



Erectors of combination insulation systems have to be trained.

Cable insulation Conlit® Bandage

Registration data





Insulation in walls/ceilings

Fire resistance class	S30, S60, S90
Proof of application	General construction approval of DIBt, Berlin
Approval number	Z-19.53-2668
Testing standard	DIN 4102 Part 9



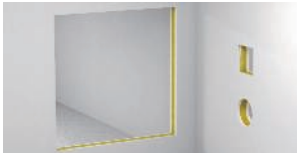

Areas of installation

Insulation systems in walls/ceilings

Component REI30

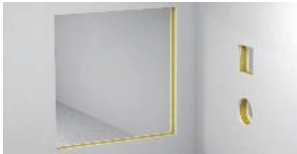
	Rigid walls	Flexible walls	Rigid floors
			
Min. component strength 	5 cm	7.5 cm (S30 / S60 / S90)	15 cm
Min. insulation thickness 	10 cm (S30 / S60 / S90)	10 cm (S30 / S60 / S90)	10 cm (S30 / S60 / S90)
Opening size 	≤ Ø 10 cm	≤ Ø 10 cm	≤ Ø 10 cm

Component REI90

	Rigid walls	Flexible walls	Rigid floors
			
Min. component strength 	10 cm	10 cm	15 cm
Min. insulation thickness 	10 cm (S30 / S60 / S90)	10 cm (S30 / S60 / S90)	10 cm (S30 / S60 / S90)
Opening size 	≤ Ø 10 cm	≤ Ø 10 cm	≤ Ø 10 cm

Cable insulation Conlit® Bandage Installations

Cable



Pipe bundle of electrical installation pipes



Cable bundle



Electrical installation pipe made of steel



Individual lines for control purposes



Cable support systems



Electrical installation pipe made of plastic, rigid



Metal pipes with path insulation



Electrical installation pipe made of plastic, flexible



Plastic pipes



 Details on the version can be found in the proof of suitability or mounting instructions. All the stated dimensions are maximum values.

Individual cables according to MLAR with insulating layer forming agent

System description

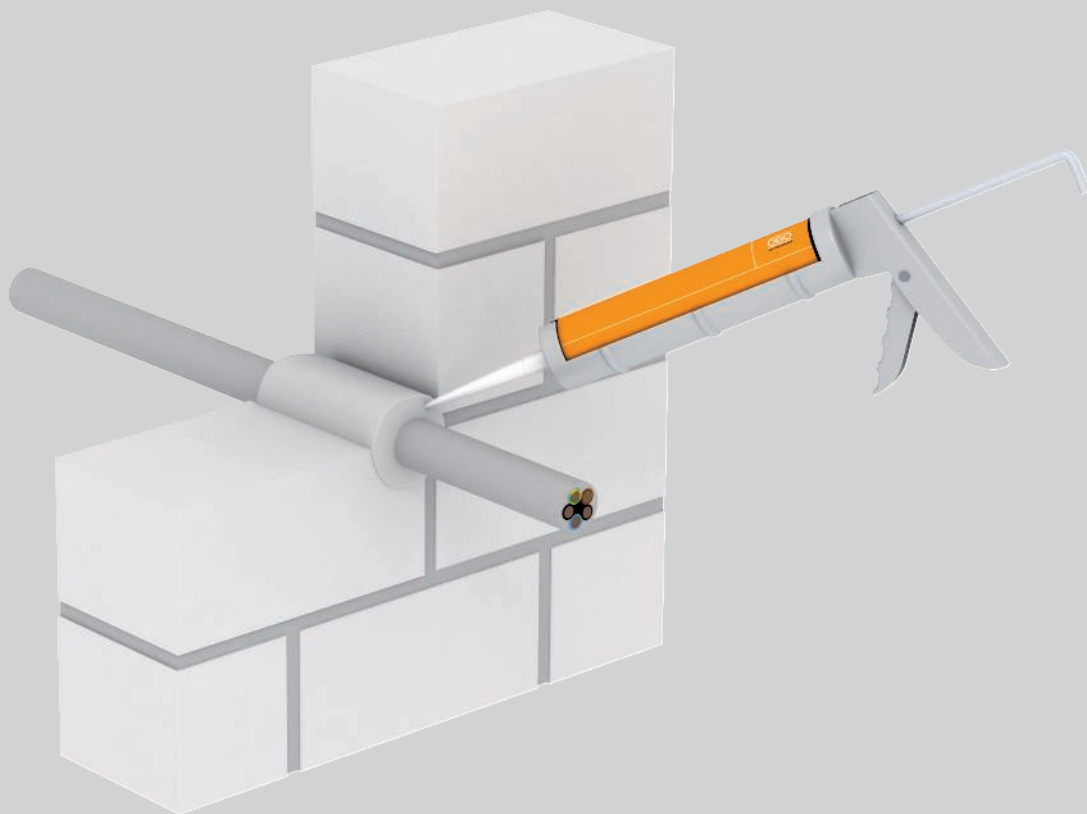

The type DSX insulation forming material from OBO can be used to fill ring gaps around individual cables or multiple cables of a small cross-section routed alongside one another. The ring gap around the cable must be filled with fire protection filler

along the entire wall thickness. If there is a fire, the filler foams up, preventing penetration by fire and smoke. When the material foams up, heat is also drawn from the cables, thus considerably reducing the transfer of heat via the copper cores.

Individual cables according to MLAR with insulating layer forming agent

Installation principle



DSX insulation layer creator, suitable for full-wall ring gap closure in solid walls and ceilings.

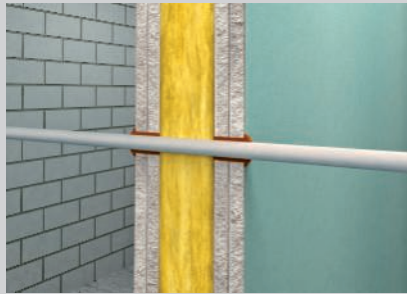

With light-duty partitions, filling the double plates to both sides is sufficient.

Classification to DIN 4102

F30

F60

F90

Insulation layer creator on dispersion basis

Material class	B2 – normally flammable
Proof of application	General construction approval of DIBt, Berlin
Approval number	Z-19.11-1991
Testing standard	DIN 4102

Minimum dimensions of components and their fire resistance period

Min. solid component strength	40	70	80
Fire resistance class	F30	F60	F90
Ring gap max.	15	15	15

All data in mm. The data in the named proofs of applicability applies.



Erectors of combination insulation systems have to be trained.

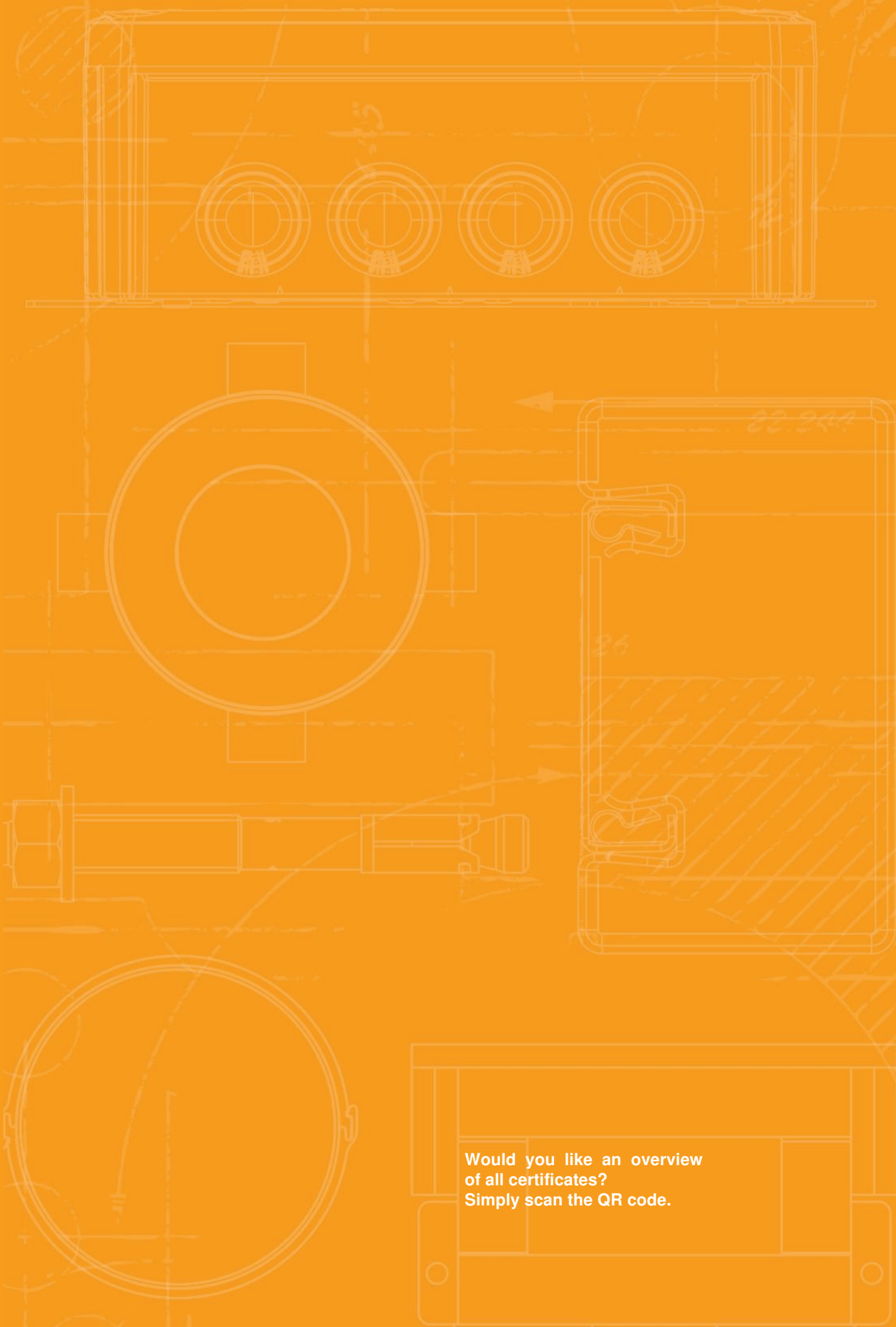

Would you like an overview
of all certificates?
Simply scan the QR code.

Cable bandages, prevention of the spread of fire



PYROWRAP® Wet FSB-WLS wet rooms/interior areas

92



PYROWRAP® Wet FSB-WLS

Application in interior areas and wet rooms

System description



The PYROWRAP® Wet FSB-WLS system can be used to wrap large cable bundles or cable support systems within the fire sections, in order to prevent the spread of a fire. The mesh possesses a fire protection coating, which stops a fire in its tracks at an early stage, e.g. in the case of a short circuit. If there is fire coming in from the outside, the material is not involved in the course of the fire, effectively preventing the spread of the fire, both in vertical and horizontal directions.

In the escape and rescue routes of small buildings, the mounting of a cable bandage is permitted, as only low smoke development is to be expected and only a small number of people must be evacuated. In larger buildings, the residual risk of smoke development is accepted, even if considerably more people must be evacuated. Here, the fire protection bandage frequently presents the only economic solution compared to fire protection ceilings or panelling with plate materials.

PYROWRAP® Wet FSB-WLS

Application in interior areas and wet rooms

Installation principle



Complete encasement of the suspended cable run.



Complete encasement of the cables in a cable run as wall mounting.



Bandage fastening with metallic rails in a single-clip installation.



Bandage fastening with metallic tightening straps in a rail installation.

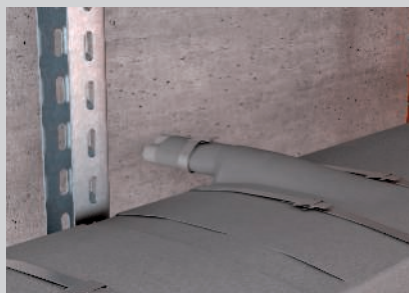

Cable exit with bandaging.



Bandaging of the cable bundles on support systems.

Cable jacketing to prevent fire spread

Proof of application	Application approval of DIBt Berlin Material approval of DIBt Berlin
Documents	Z-56.217-3600 Z-19.11-2183
Prevention of fire spread	Min. 90 minutes
Material properties	Exterior grey glass fibre mesh, interior light grey materials class C-s2, d0 according to EN 13501-1 – hardly flammable
Max. fastening spacing	0.5 m
Cable types and cross-sections	No restriction

Caution!

Use in emergency and escape routes of building classes 4 and 5 may require the approval of the construction supervision, e.g. through a fire protection concept.

PYROWRAP® Wet FSB-WB

Application in industrial areas/outdoors

System description

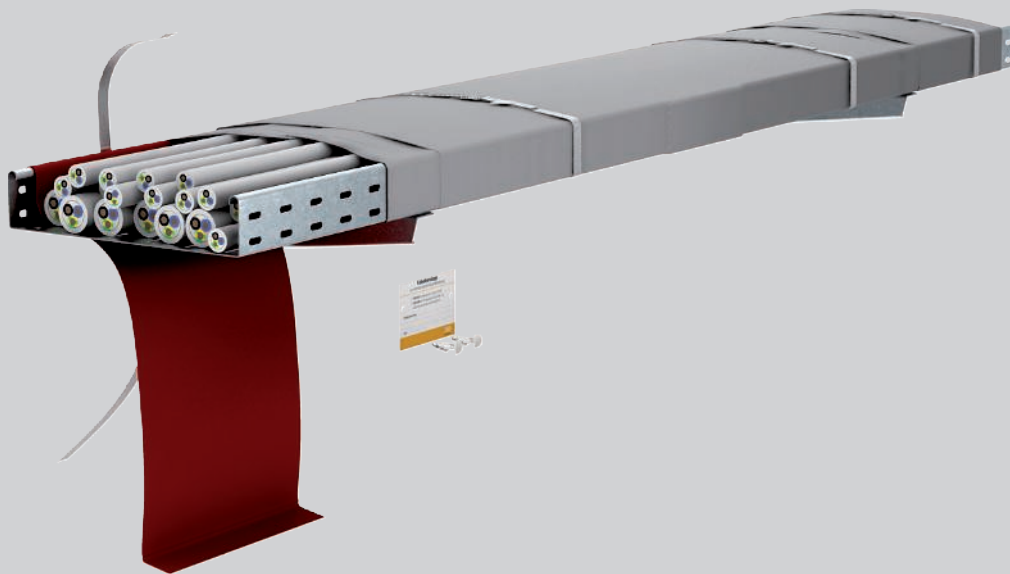

The PYROWRAP® Wet FSB-WB system comprises a fire protection bandage, which is used in areas with special environmental conditions. The fire protection bandage can be used to wrap large cable bundles or cable support systems, in order to prevent the spread of fire. The bandage is made of a weatherproof material, which is insensitive to

various chemicals and oils. It has construction approval from the DIBt as a highly flame-resistant material according to DIN EN 13501-1. When the fire protection coating foams up in the event of fire, this safely prevents the spread of fire via the cables.

PYROWRAP® Wet FSB-WB

Application in industrial areas/outdoors

Installation principle



Use of the bandage in aggressive environments, e.g. offshore.



Bandaged rising section in the tower of a wind power plant.



Use on support systems in supply rooms or production halls.



Cable tunnel with bandages in power stations.



Bandaged cable support systems in areas with many combustible materials.



Use for photovoltaic cables run over a fire wall.

Cable jacketing to prevent fire spread

Proof of application	IEC test report of the iBMB MPA materials testing institute, Braunschweig National and European material approval of DIBt Berlin
Document no.	IEC-3630/081/10-AR Z-19.11-1971 ETA-13/0158
Prevention of fire spread	Min. 120 minutes
Material properties	Exterior grey glass fibre mesh, interior red Materials class EN 13501-1: B1, d0,s1 – hardly flammable Weather-resistant, resistant to various chemicals and oils
Max. fastening spacing	0.5 m
Cable types and cross-sections	No restriction

Caution!

The use of photovoltaic cables over fire walls may require the approval of the local construction authorities. A positive special report is available.





Fire protection duct for roof structures, to prevent the spread of fire

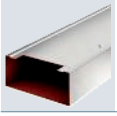

PYROLINE® Rapid PLMR metal fire protection duct

100



PYROLINE® PLMR

Fire protection duct for external applications

System description

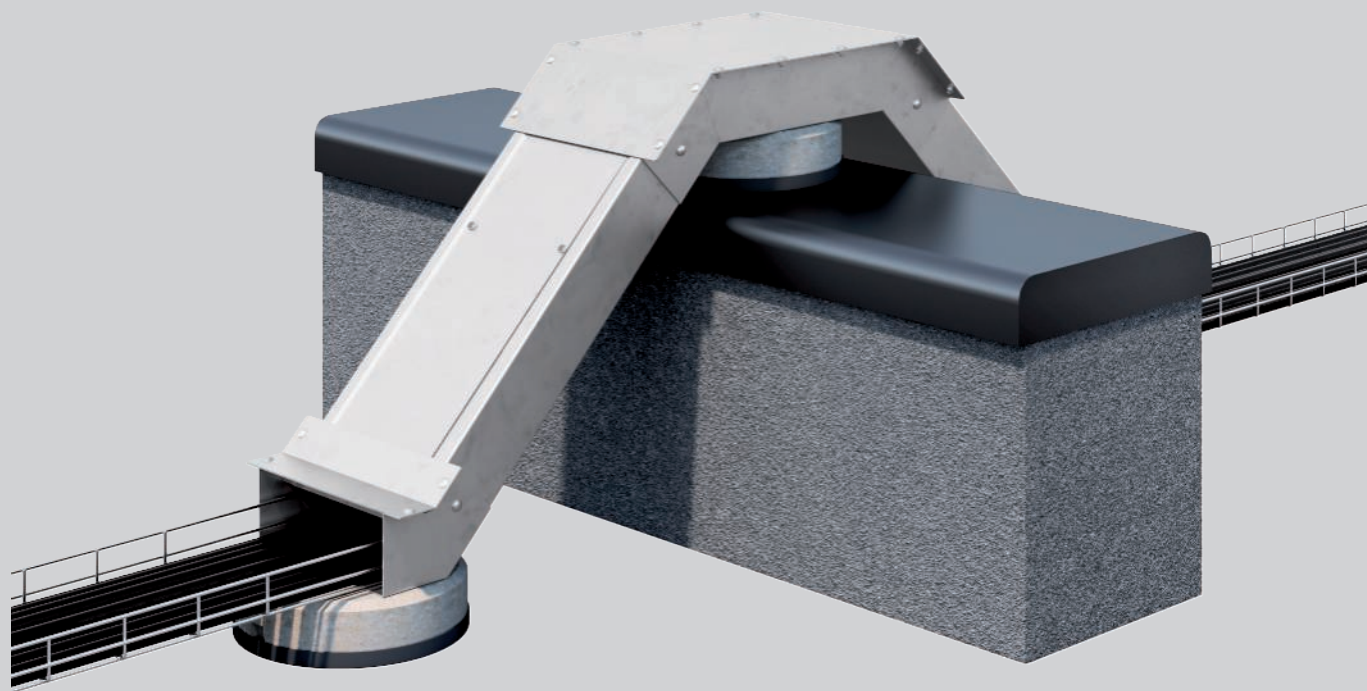

The PYROLINE® PLMR installation duct with intumescent fire protection mesh prevents the spread of fire and protects against the effects of a cable fire. It offers a fire resistance period of up to 90 minutes. Obstacles in external areas can be overcome using the stainless steel installation duct and the matching fittings. Mounting can take place on FangFix concrete blocks. The screws to fasten the duct cover are included in the scope of delivery.

Can be used as a special solution for the routing of cables over fire walls according to the expert opinion GA-2021/047b-Nau. Solution according to the EitAnlagen 2020 of the BMI +AMEV (Section 7.3.3.5 - Photovoltaic systems - Fire protection). Only the appropriate pre-terminated fittings may be used.

PYROLINE® PLMR

Fire protection duct for external applications

Installation principle

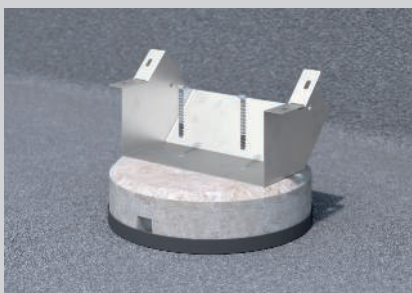

Fastening of the level, rising, on the FangFix concrete block.

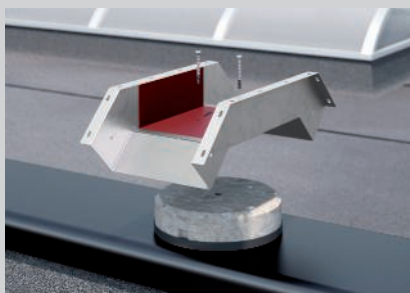

Fastening of the level, double falling, on the FangFix concrete block.

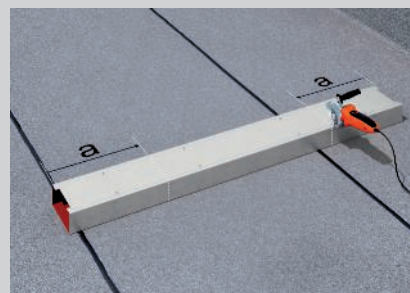

Cutting of the installation duct to the required length.

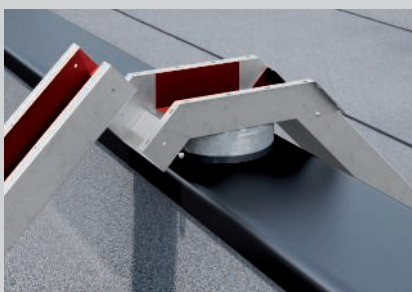

Joining of installation duct and fittings.

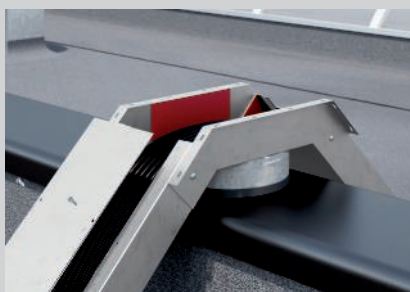

Mounting of the duct cover after cable routing.

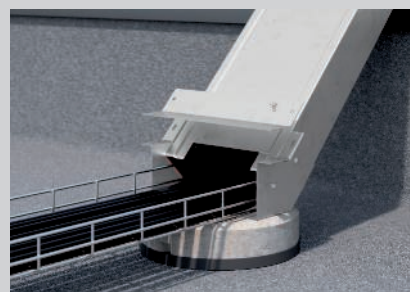

Mounting of the level cover, rising.



Mounting of the level cover, double falling.



Mounting example of the installation duct with fittings to overcome obstacles.



Application example of the stainless steel installation duct.

Installation duct to prevent the spread of fire

Proofs of usability	IEC test report of the iBMB MPA Materials Testing Institute, Braunschweig European Material Approval of the DIBt Surveyor's report by the IBB
Documents	IEC 60332-3-22 Cat. A test report no. 3630/081/10-AR ETA-18/0430 Declaration of performance 05-DOP-012 GA-2021/047b-Nau
Prevention of fire spread	Min. 90 minutes
Material properties	Corrosion-resistant stainless steel duct with intumescent fire protection mesh
Material class, fire protection mesh	C-s2,d0 according to EN 13501-1 - hardly flammable
Cable types and cross-sections	No restriction

Concrete base for FangFix system, min. 10 kg

BET

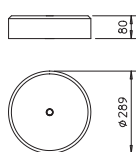

Type	Nominal size Ø mm	Pack Piece	Weight kg/100 pc.	Item no.
F-FIX-S10	289	1	1,000.000	5403117

- Min. 10 kg block of Ø 289 mm, high level of stability
- Frost-resistant concrete
- Stackable

Base for FangFix system 10 kg

PP

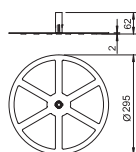
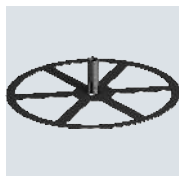





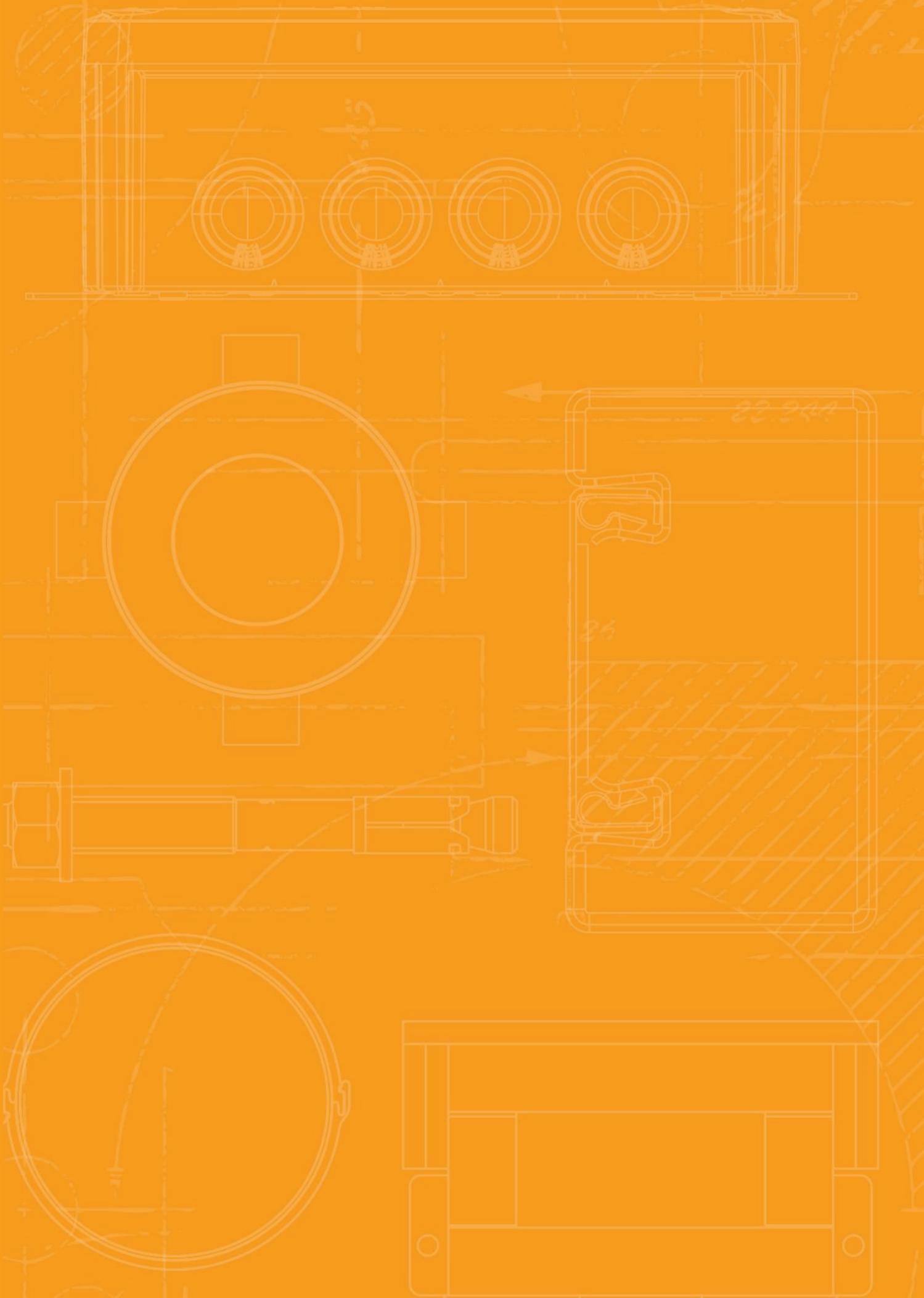

Type	Nominal size Ø mm	Pack Piece	Weight kg/100 pc.	Item no.
F-FIX-B10	295	10	7,600	5403124

Edge protection with integrated dowel (basic) suitable for FangFix 10 kg system.











































Directories

	Test marks	106
	Pictogram explanation	108
	Alphabetical table of contents	112
	Type listing	114
	Numeric directory	116
	For the latest general conditions of sale and delivery please see www.obo.global/general-purchasing-conditions/	

























Test marks

	American Bureau of Shipping, USA		Underwriters Laboratories Inc., USA + CSA, Canada
	AENOR, Producto Certificado, Spain		Österreichischer Verband für Elektrotechnik, Austria
	STOWARZYSZENIE ELEKTRYKÓW POLSKICH, Poland		ISTITUTO ITALIANO DEL MARCHO DI QUALITÀ, Italy
	Lightning current-tested		RINA 1861, Ship Classification, Certification and Services
	Lightning current-tested, Class H (100 kA)		Underwriters Laboratories Inc., USA
	CEBEC, Belgium		SEMKO An Inchcape Testing Services Company, Sweden
	Canadian Standards Association, Canada		Eidgenössisches Starkstrominspektorat, Switzerland
	DEMKO, Danmarks Elektriske Materielkontrol, Denmark		South African Bureau of Standards
	Deutsches Institut für Bautechnik Berlin, Germany		Shock-tested, Bundesamt für Zivilschutz, Germany
	Det Norske Veritas		Sähkötarkastuskeskus Elinspektionscentralen Electrical Inspectorate, Finland
	ENEC Austria		Underwriters Laboratories Inc., USA
	ATEX certificate for explosive areas		Underwriters Laboratories Inc., USA
	ELEKTROTECHNICKÝ ZKUŠEBNÍ ÚSTAV, Czech Republic		Verband der Elektrotechnik, Elektronik, Informationstechnik e.V., Germany
	FIMKO, Finland		German Association of Electricians, tested safety
	Forschungs- und Materialprüfungsanstalt, Germany		5-year warranty
	Russia, GOST The State Committee for Standards		
	Test marks for technical resources, VDE Prüf- und Zertifizierungsinstitut Offenbach, Germany		
	Halogen-free; without chlorine, fluorine and bromine		
	INMETRO, Brazil		
	KEMA-KEUR, Netherlands		
	Indication of metric products		
	MAGYAR ELEKTROTECHNIKAI ELLENŐRZŐ INTÉZET Budapest, Hungary		
	NEMKO, Norway		
	AFNOR Quality symbol of the French standardisation institute		





Pictogram explanation





Surfaces

 FS	Strip galvanised
 FSK	Strip galvanised/plastic-coated
 DD	Strip galvanised zinc/aluminium, double dip
 BK	Bright
 2B	Bright, reworked
 EL	Anodised
 F	Hot-dip galvanised
 G	Electrogalvanised
 GK	Electrogalvanised/plastic-coated
 GCL	Electrogalvanised, yellow-chromatised
 GGP	Electrogalvanised, yellow passivated
 GTP	Electrogalvanised, transparently passivated
 GR	Primed
 L	Painted
 SG	Welding primed
 FT	Hot-dip galvanised
 FT SO	Hot-dip galvanised 85 µm
 Cu	Copper-plated
 N	Nickel-plated
 ZD	Galvanised, Deltatone 500
 ZDM	Galvanised, MAGNI 565
 GA	Zinc-aluminium coated, Galfan
 ZL	Zinc scale





Conformity symbol

 CE	Communautés Européennes, EC declaration of conformity according to EC directives
 RoHS	RoHS-conformant



















Quality marks

	Halogen-free; without chlorine, fluorine and bromine
	Flame resistant 650 °C
	Flame resistant 750 °C
	Flame resistant 960 °C
	UV-resistant



Specific product symbols

	Diameter 60 mm
	Diameter 68 mm
	Protection device to DIN EN 61643-11 or IEC 61643-11
	Transition from LPZ 2 to LPZ 3
	Acoustic signalling

Applications



	Remote signalling
	Acoustic signalling
	Integrated Service Digital Network, ISDN applications
	Digital Subscriber Line, DSL applications
	Analogue telecommunication
	Category 5 TwisterPair
	Channel Performance to American EIA/TIA standard
	Measuring, controlling and regulating systems
	TV applications
	SAT-TV applications
	MultiBase base
	LifeControl
	Intrinsically safe protection device for potentially explosive areas
	Channel Performance to ISO/IEC 11801
	Power over Ethernet
	230/400 V system
	Protection rating IP 54
	Protection rating IP 65

Lightning protection classes







	Protection device to DIN EN 61643-11 or IEC 61643-11
	Combination protection device made of type 1 and type 2
	Protection device to DIN EN 61643-11 or IEC 61643-11







Lightning protection classes

	Protection device to DIN EN 61643-11 or IEC 61643-11
	Protection device to DIN EN 61643-11 or IEC 61643-11



Lightning protection zone

	Transition from LPZ 0 to LPZ 1
	Transition from LPZ 0 to LPZ 2
	Transition from LPZ 0 to LPZ 3
	Transition from LPZ 1 to LPZ 2
	Transition from LPZ 1 to LPZ 3
	Transition from LPZ 2 to LPZ 3



BSS maintenance of electrical function installation

	Fire-tested systems
	Escape route ceiling mounting with pressure clip
	OBO Grip, wall routing type
	OBO Grip, ceiling routing type
	Pressure clip for maintenance of electrical function, ceiling mounting



BSS anchor

	Fire protection anchor
	Fire protection bolt tie

BSS test marks/material class

	Maintenance of electrical function class E30
	Maintenance of electrical function class E90













Clamp clip base shapes

	Clamp clip for C profile rail, slot width 11–12 mm
	Clamp clip for C profile rail, slot width 16–17 mm
	Clamp clip for C profile rail, slot width 18–22 mm



Diameter

	Diameter 60 mm
	Diameter 68 mm
	Diameter 70 mm
	Diameter 74 mm





Entries

	4 cable entries
	6 cable entries
	7 cable entries
	8 cable entries
	9 cable entries
	10 cable entries
	12 cable entries
	10 cable entries ECO
	12 cable entries ECO
	14 cable entries ECO
	16 cable entries
	18 cable entries ECO
	24 cable entries





Gland thread

	Thread metric
	Thread Pg





Entry size

	M20 entry
	M25 entry
	M32 entry
	M40 entry

KTS side heights









	Cable tray, side height 35 mm
	Cable tray, side height 60 mm
	Cable tray, side height 85 mm
	Mesh cable tray, side height 35 mm
	Mesh cable tray, side height 55 mm

Materials



	Flat steel
	Angular steel
	U steel
	Round material

Pictogram explanation







Nominal cross-section

	Nominal cross-section 1.5 mm ²
	Nominal cross-section 1.5–2.5 mm ²
	Nominal cross-section 2.5 mm ²
	Nominal cross-section 2.5–4 mm ²
	Nominal cross-section 4 mm ²
	Nominal cross-section 4–6 mm ²
	Nominal cross-section 6 mm ²
	Nominal cross-section 10 mm ²
	Nominal cross-section 16 mm ²













Nominal voltage

	Nominal voltage 400 V
	Nominal voltage 500 V
	Nominal voltage 660 V





Polarity

	3-pole
	5-pole
	7-pole
	8-pole
	10-pole
	12-pole



Slot widths

	Slot width 7.5 mm
	Slot width 11 mm
	Slot width 11–12 mm
	Slot width 12 mm
	Slot width 15 mm
	Slot width 16 mm
	Slot width 16.5 mm
	Slot width 16–17 mm
	Slot width 17 mm
	Slot width 18 mm
	Slot width 22 mm
	Slot width 35 mm











Screw heads

	Philips screw
	Torx screw
	Phillips screw
	Pozidriv











Firing devices

	Bolt-firing tool
	Nail device





Protection rating

	Protection rating IP 20
	Protection rating IP 30
	Protection rating IP 31
	Protection rating IP 44
	Protection rating IP 54
	Protection rating IP 55
	Protection rating IP 65
	Protection rating IP 66
	Protection rating IP 67
	Protection rating IP 68

Metals

	Aluminium
	Aluminium/steel
	Stainless steel, rustproof
	Stainless steel, rustproof
	Stainless steel, rustproof
	Copper
	Brass
	Steel
	Malleable iron
	Die-cast zinc

Plastics

	Acrylonitrile butadiene styrene
	Duroplast, Aminoplast, type 131.5
	Duroplast, melamine resin, type 150
	Ethylene vinyl acetate

Plastics

FA	Fibre-proof material DIN 28091
GFK	Fibreglass-reinforced plastic
NBR SBR	Rubber mixture
NBR	Nitrile rubber
PETR	Petrolatum
PA	Polyamide
PA/ GF	Polyamide, fibreglass reinforced
PBPT	Polybutylene terephthalate
PC	Polycarbonate
PE	Polyethylene
PP	Polypropylene
PP/ GF	Polypropylene, fibreglass reinforced
PS	Polystyrene
PVC	Polyvinylchloride
ZELL PC	Cellular polyethylene



Alphabetical table of contents

B

Base for FangFix system 10 kg; 102

C

Concrete base for FangFix system, min. 10 kg; 102

F

Fire protection bolt tie; 26, 38, 70, 76

M

Mineral fibre plate, pre-coated; 32

T

Threaded rod; 26, 32, 76





Type listing

Type	GTIN	Item no.	Page
F-FIX-B10	5070085	/100 pc. 5403124	102
F-FIX-S10	5070078	5403117	102
MMS+ MS 7.5x50	6559664	3498261	26
MMS+ MS 7.5x50	6559664	3498261	38
MMS+ MS 7.5x50	6559664	3498261	70
MMS+ MS 7.5x50	6559664	3498261	76
MMS+ P 6x35	6651290	3498103	26
MMS+ P 6x35	6651290	3498103	76
MMS+ P 6x50	6559657	/100 pc. 3498108	26
MMS+ P 6x50	6559657	3498108	76
PSX-P60	6649594	7202297	32
TR M8 1M G	5253334	/100 pc. 3141128	26
TR M8 1M G	5253334	3141128	32
TR M8 1M G	5253334	3141128	76



Numeric directory

GTIN	Item no.	Page
5253334	/100 pc. 3141128	26
6651290	3498103	26
6559657	/100 pc. 3498108	26
6559664	3498261	26
5070078	5403117	102
5070085	5403124	102
6649594	7202297	32







© OBO Bettermann 07/2023 NO

OBO Bettermann AS

Hvamveien 4
2013 Skjetten

www.obo-bettermann.no

Kundeservice Norge

Tlf.: +47 64 80 22 22
info@obo-bettermann.no

Building Connections

OBO
BETTERMANN